

domnick hunter PNEUDRI

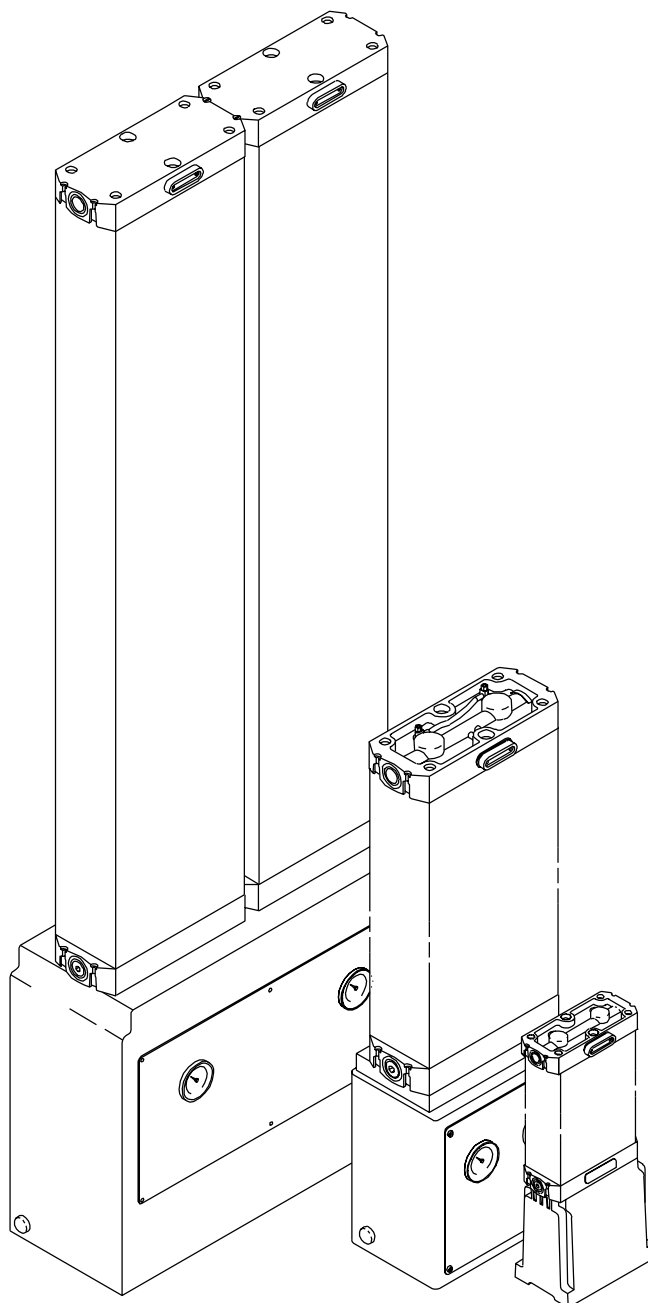

MAINTENANCE MANUAL

DATE : 25Oct99

REV: 4

FOREWORD

The compressed air dryer systems have been designed and manufactured to ensure that maximum safety and performance is achieved. It is expected that users of these systems will employ safe working practices and ensure that when installing, commissioning, operating or maintaining the equipment, any legal requirements are fulfilled. For example, in the UK, users should refer to the Health and Safety Act, 1974.

All ancillary equipment such as pipework, valves, fittings etc., must be suitable for the pressures and capacities involved.

Replacement parts are available from your distributor or the manufacturers (see front page for information). The adoption of a regular servicing policy is strongly recommended and will result in ensuring that a high performance is achieved. Serial numbers and customer order numbers should be referred to in any communication. (Serial numbers can be found on the identification plate attached to the dryer). The figure number and the appropriate diagram in this manual and the item number (shown in circle,) will also assist in part identification.

Any warranty will be invalidated if the dryer is not installed in accordance with the manufacturers recommendations or non-approved parts substituted. Substitute parts could reduce the performance or service life in addition to creating potential hazards.

The manufacturers reserve the right to modify the contents of this manual without notice. The data given is a guideline to users and in no way binding on the manufacturers.

BEFORE SERVICING OR DISMANTLING ALL PRESSURE MUST BE RELEASED FROM THE SYSTEM AND ITS ASSOCIATED PIPEWORK AND ANY ELECTRICAL SUPPLY ISOLATED.

RECOMMENDED ROUTINE MAINTENANCE

Weekly

1. Ensure drain function / operation on all filters.
2. Ensure the change-over occurs approximately every 2 mins.
3. Check all gaskets, control valves, pipes and fittings for air leaks.
4. Ensure moisture indicator paper is blue.

Inlet / Outlet elements should be changed every 6000 / 8000 hrs.

Section	Description	Page No
A1	Outlet Head Assembly.	
A2	Column Assembly.	
A3	Inlet Head Assembly.	
A4	Cam-Timer Replacement.	
A5	Fault Finding Guide.	
A6	Piping Schematic Diagrams.	

A diagram showing a horizontal rectangular box with the word "SECTION" inside. To its right is a vertical rectangular box with the number "A1" inside. The two boxes overlap, with the vertical box positioned in front of the horizontal one.

SECTION **A1**

OUTLET HEAD ASSEMBLY

- A1.1 Upper Gasket Replacement**
- A1.2 Moisture Indicator Removal**
- A1.3 Check Valve Replacement**
- A1.4 Adjustment of variable purge**

MINI OUTLET HEAD

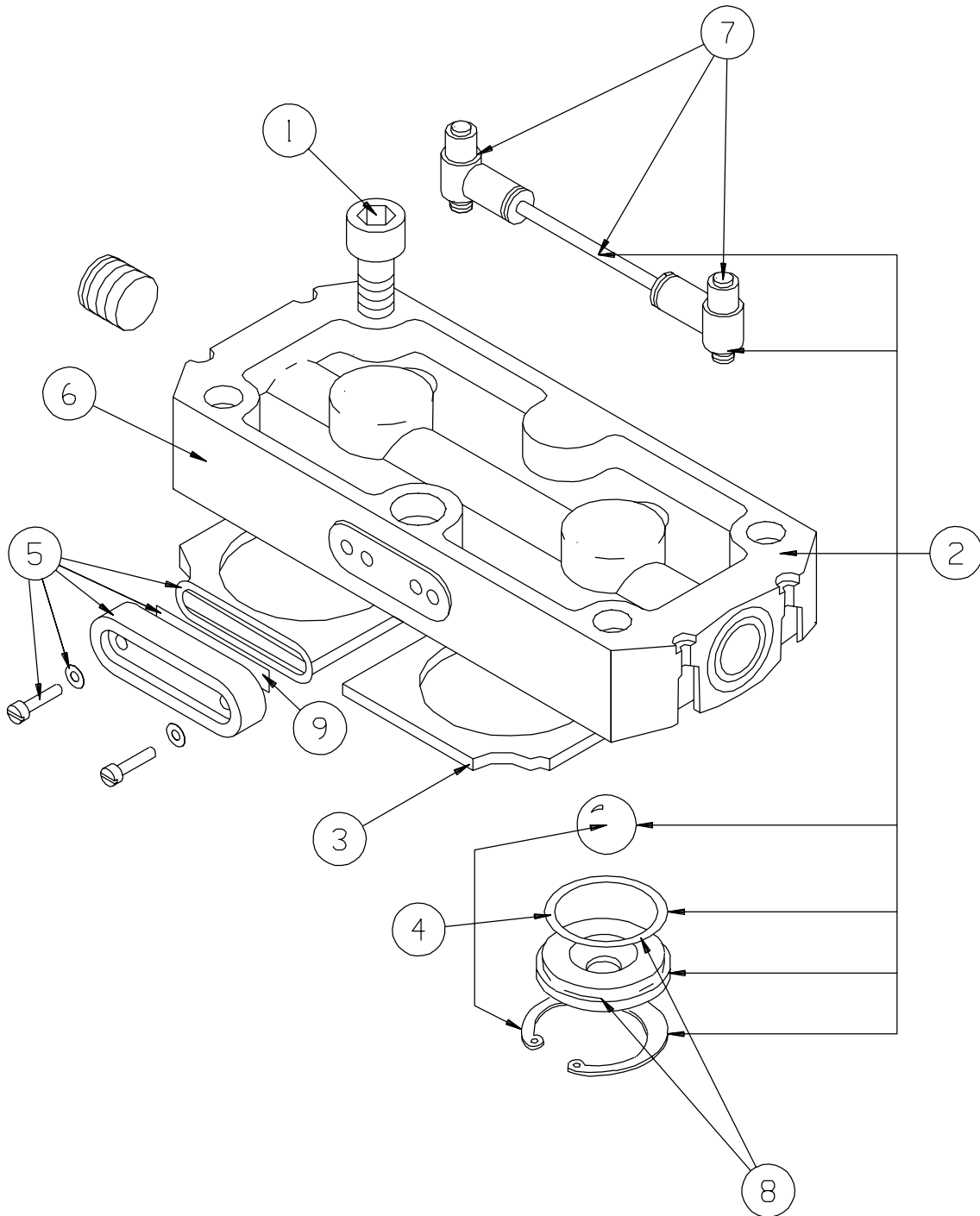

MIDI OUTLET HEAD (12 - 25 l/s)

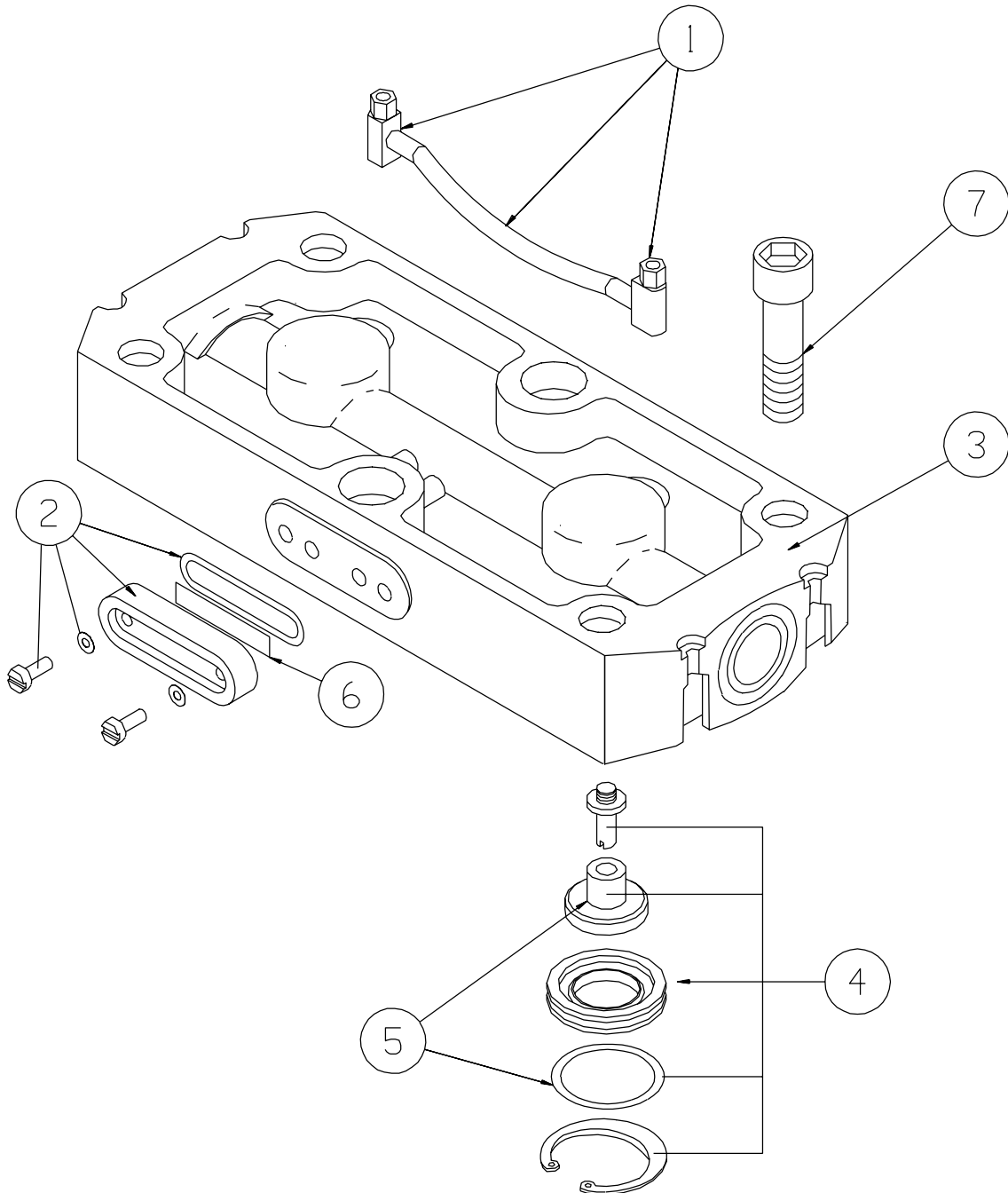

MIDI DUPLEX OUTLET HEAD (Also 31 - 42 l/s)

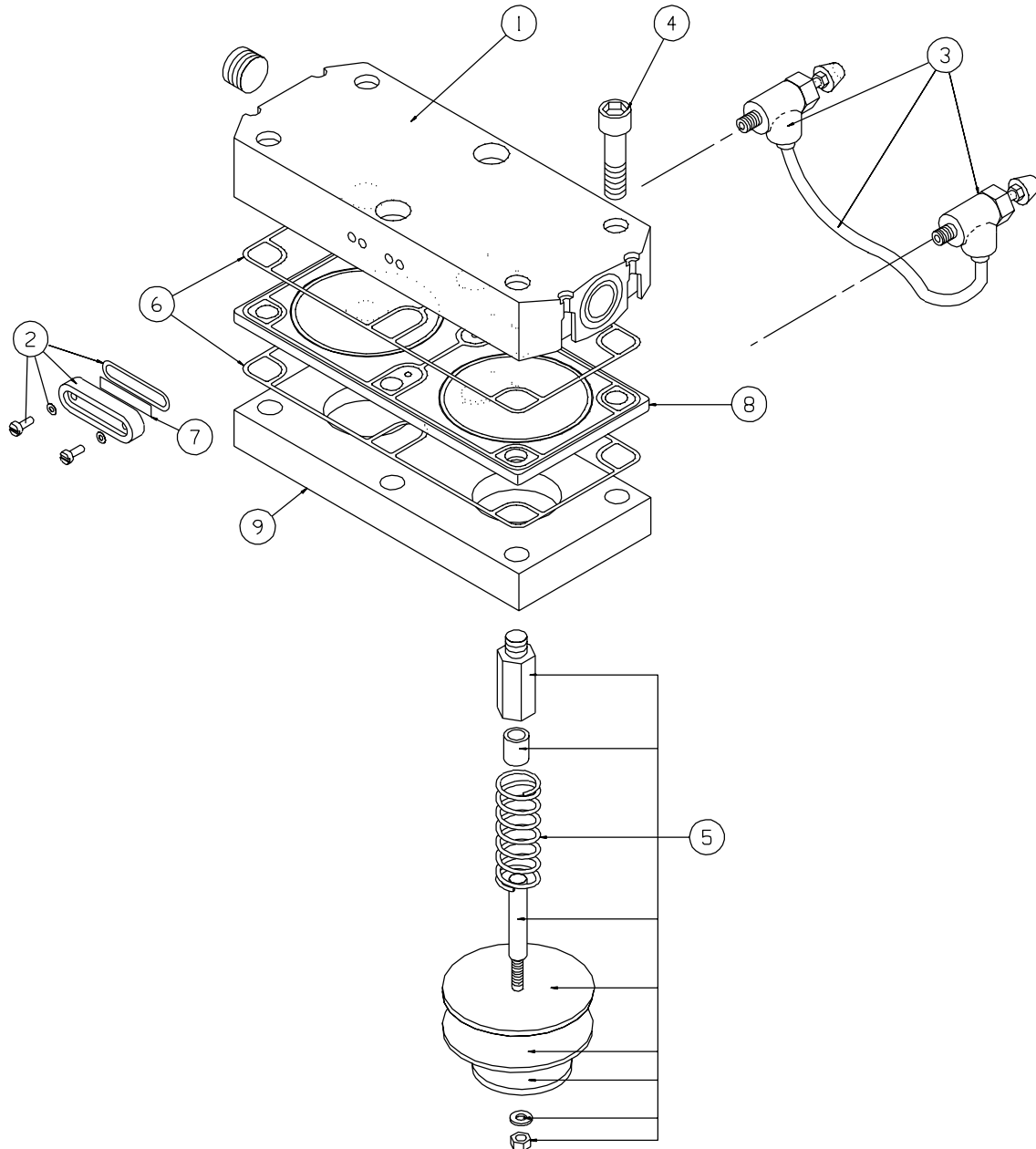

A1.1 UPPER GASKET REPLACEMENT

Disconnect outlet pipework. Remove head bolts, lift head clear.

DM 002 - 006

Replace neoprene gaskets

DM 012 - 080

Replace moulded O ring gaskets

A1.2 MOISTURE INDICATOR REMOVAL

Remove two screws from sight glass. Change indicator paper and refit, ensuring gasket is in good condition and the air holes are clear.

A1.3 CHECK VALVE REPLACEMENT

DM 002 - 025

Remove outlet head as above. Remove circlip and valve seat with o-ring. Remove check valve.

QAX 030 - 080

Remove outlet head and purge plate.

Invert complete assembly.

Remove purge plate.

The check valve assembly can now be removed from the head.

NB Check valve guides are scewed into the inlet head.

DM 002 - 006 TORQUE HEAD BOLTS TO 35NM (25 lbf ft)

DM 012 - 080 TORQUE HEAD BOLTS TO 75NM (55lbf ft)

TORQUE SEQUENCE

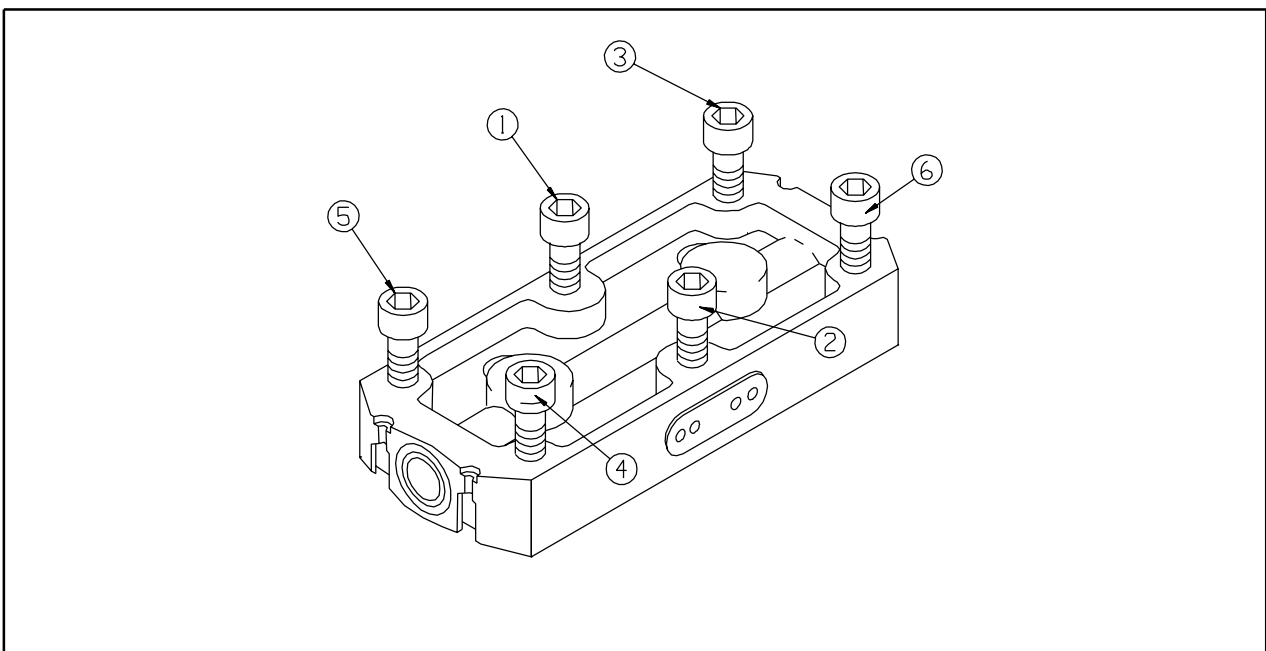

PURGE ADJUSTMENT

SECTION

A1

GENERAL

A1.4 ADJUSTMENT OF VARIABLE PURGE

The variable purge needle valves are situated in the top or rear of the outlet head on the dryer.

NOTE:

The dryer purge needle valves are factory set for 20% of rated flow of the dryer at 7 barg (102 psig) inlet pressure (18% actual @ 6 barg) The purge needle valves only require adjustment if the inlet pressure to the dryer is not 7 bar g (102 psig).

TO ADJUST THE PURGE

- A** Turn both valve adjusting screws clockwise until they are fully closed .
DO NOT OVER TIGHTEN THESE SCREWS.
- B** The 4mm or 6mm plastic pipe which connects both valves together should be removed from the push in connections on the valves by pressing on the face of the connection to release the collet.
- C** A flow meter (not supplied) which is capable of measuring the amount of purge air required should be fitted to either one of the purge needle valves.
- D** Allow the column, on which the purge needle valve functions to pressurise. Turn the adjusting screw in an anticlockwise direction until the desired purge flow setting is obtained. If the flow meter does not register after **THREE TURNS**, the adjacent column is pressurising, wait for the desired column to pressurise and continue.
- E** The operating pressure must be maintained throughout in order for the purge flow setting to be correct.
- F** When the above operation is complete and the correct purge flow is obtained, wait until the adjacent column pressurises. Remove the flow meter from the previously adjusted valve and attach to the unadjusted valve. Turn the adjusting screw anticlockwise until the desired purge flow setting is obtained.
- G** After adjustment has been carried out, remove the flow meter from the previously adjusted valve. Replace the 4mm or 6mm plastic pipe. A proportionate amount of purge air will exhaust when this pipe is being fitted, relative to the capacity of the dryer.
- H** The correctly adjusted unit is now ready for use. For settings other than 7 bar g, consult the manufacturer.

NOTE: The maximum rated capacity of the flow meter as recommended by the manufacturers instructions should be checked before use.

A1.5 Purge Flow Rates 5 - 10 barg

DRYER TYPE	L/Min
DM 002	17
DM 003	34
DM 006	74
DM 012	136
DM 015	181
DM 020	238
DM 025	300
DM 030	368
DM 040	498
DM 050	600
DM 060	736
DM 080	997



SECTION **A2**

COLUMN ASSEMBLY

- A2.1 Column/Desiccant Removal**
- A2.2 Desiccant Replacement**
- A2.3 General**

COLUMN ASSEMBLIES

SECTION A2

MINI

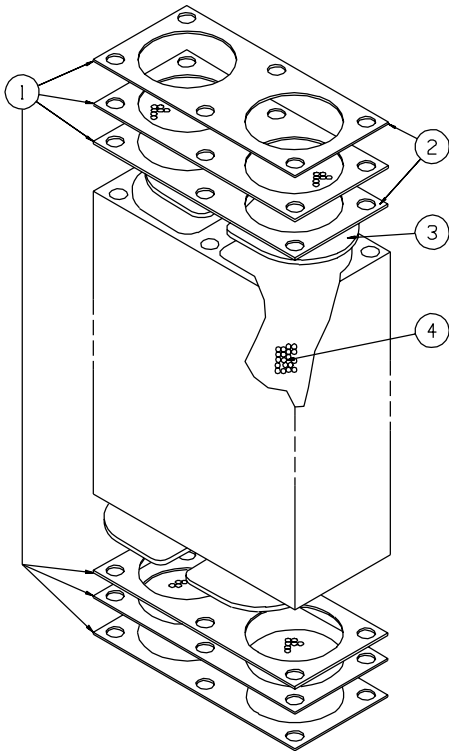

DRYER DESICCANT CHANGE KIT DETAILS			
FLOWRATE	ITEM 4	ITEM 3	ITEM 2
4 SCFM	1	1	1
6 SCFM	1	1	1
13 SCFM	2	1	1

MIDI

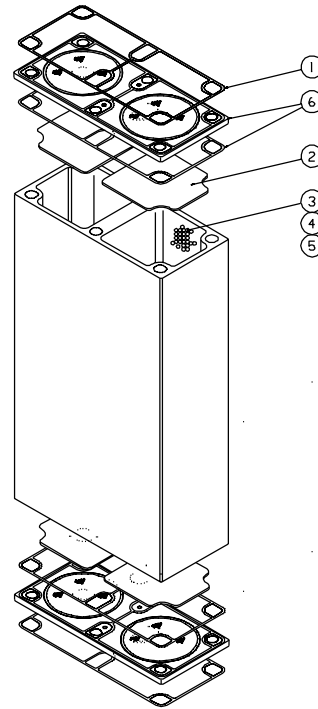

DESICCANT KIT DETAILS			
FLOW RATE L/3 @ 7 Barg	ITEM NUMBER AND QUANTITY REQUIRED		
	ITEM 3	ITEM 4	ITEM 5
12		1	
15	2	1	
20		2	
25	2	2	
31		3	
42			1
50		1	1
62		2	1
84			2

A2.1 COLUMN / DESICCANT REMOVAL

Remove outlet head assembly and upper gasket. Remove upper column pads and remove desiccant by either inverting dryer or by means of an industrial vacuum cleaner. The bottom column bolts can be removed and the column lifted clear although complete removal of the column is not always necessary.

NOTE : DESICCANT IS NOT REUSEABLE AND MUST BE DISCARDED.

A2.2 DESICCANT REPLACEMENT

Ensure the columns are free from dust, fit new lower column pads and check lower gasket is in good condition. Refilling can now take place. In order to maintain dryer performance, the columns must be refilled using a snowstorm filling device which will achieve maximum packing density. The best results are obtained by using a smooth continuous operation.

A2.3 GENERAL

Each extrusion consists of 2 chambers filled with desiccant material. The manufacturer suggests a performance life of 10,000 - 30,000 hours, many factors can influence this nominal figure which should only be used as a guide. Accurate dewpoint monitoring with a hygrometer is the only true indication of the desiccant material condition. (Consult the manufacturer).



INLET HEAD ASSEMBLY

- A3.1 Bottom Gasket Replacement**
- A3.2 Silencer Replacement (Mini)**
- A3.3 Control Valve Replacement**
- A3.4 Exhaust Valve Replacement
(Midi Only)**

A3.1 BOTTOM GASKET REPLACEMENT

Disconnect the inlet and outlet pipework. Invert dryer if possible ensuring the purge regulators are not damaged during this operation. Remove base plate or control panel by removing 4 screws from the control box. This will give access to the column bolts, remove these from sub plate and lift column clear.

A3.2 SILENCER REPLACEMENT (MINI)

Remove control box as above, this will give access to exhaust silencer.

SILENCER REPLACEMENT (MIDI)

Unscrew silencer from exhaust valve.

A3.3 CONTROL VALVE REPLACEMENT

Remove control panel or base plate from control box, remove bolts from control valve and lift clear. Ensure o-rings are in place before refitting.

A3.4 EXHAUST VALVE REPLACEMENT (MIDI ONLY)

Remove control panel from control box, control pipe from valve, unscrew silencer from valve then unscrew valve from sub plate pipework. The exhaust valve can now be lifted clear.

For re-assembly follow the reverse procedure always fitting new gaskets and o-rings.

TORQUE SUB-PLATE BOLTS TO 34N.m (25lbf ft)

MINI INLET HEAD

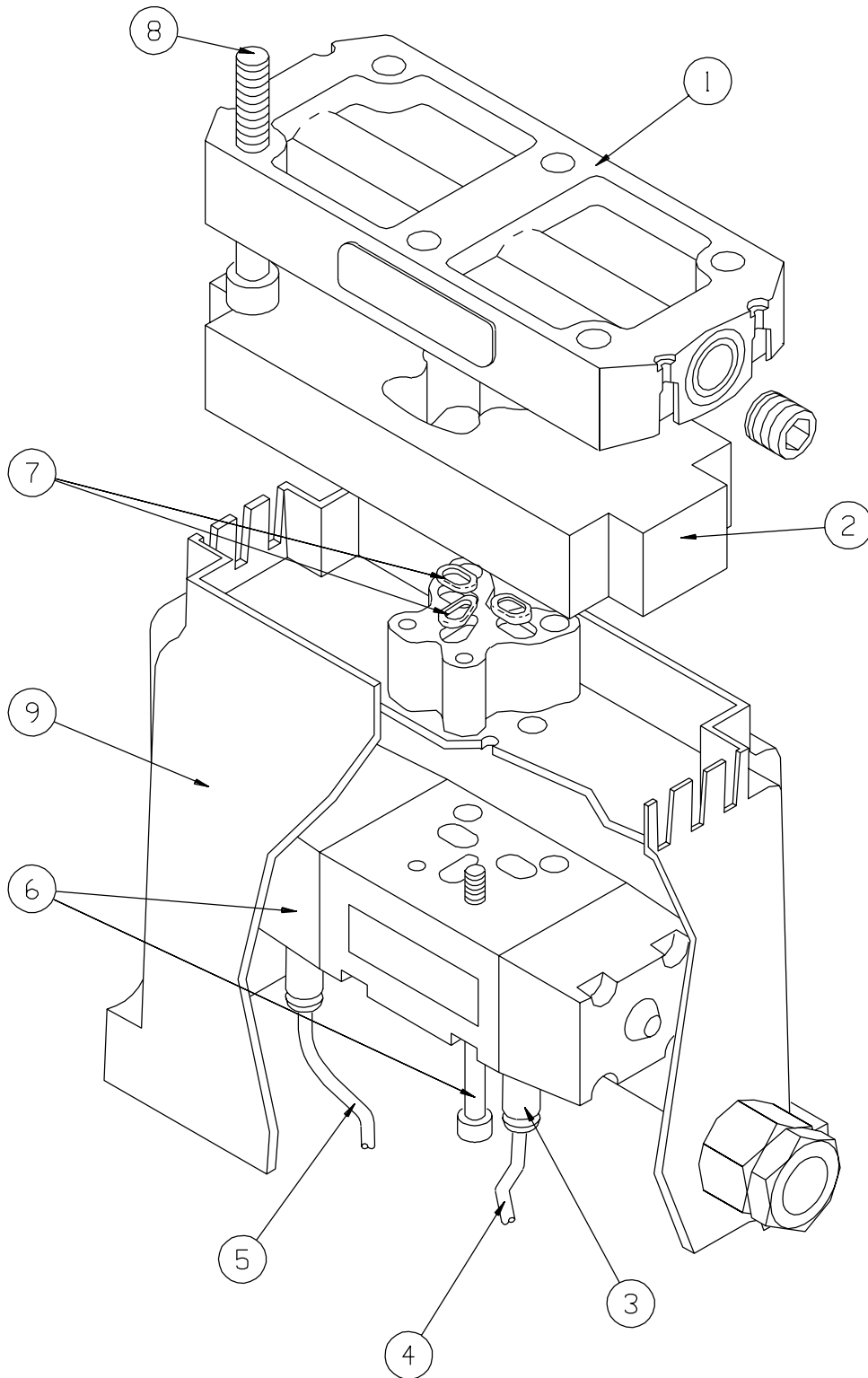

MIDI INLET HEAD

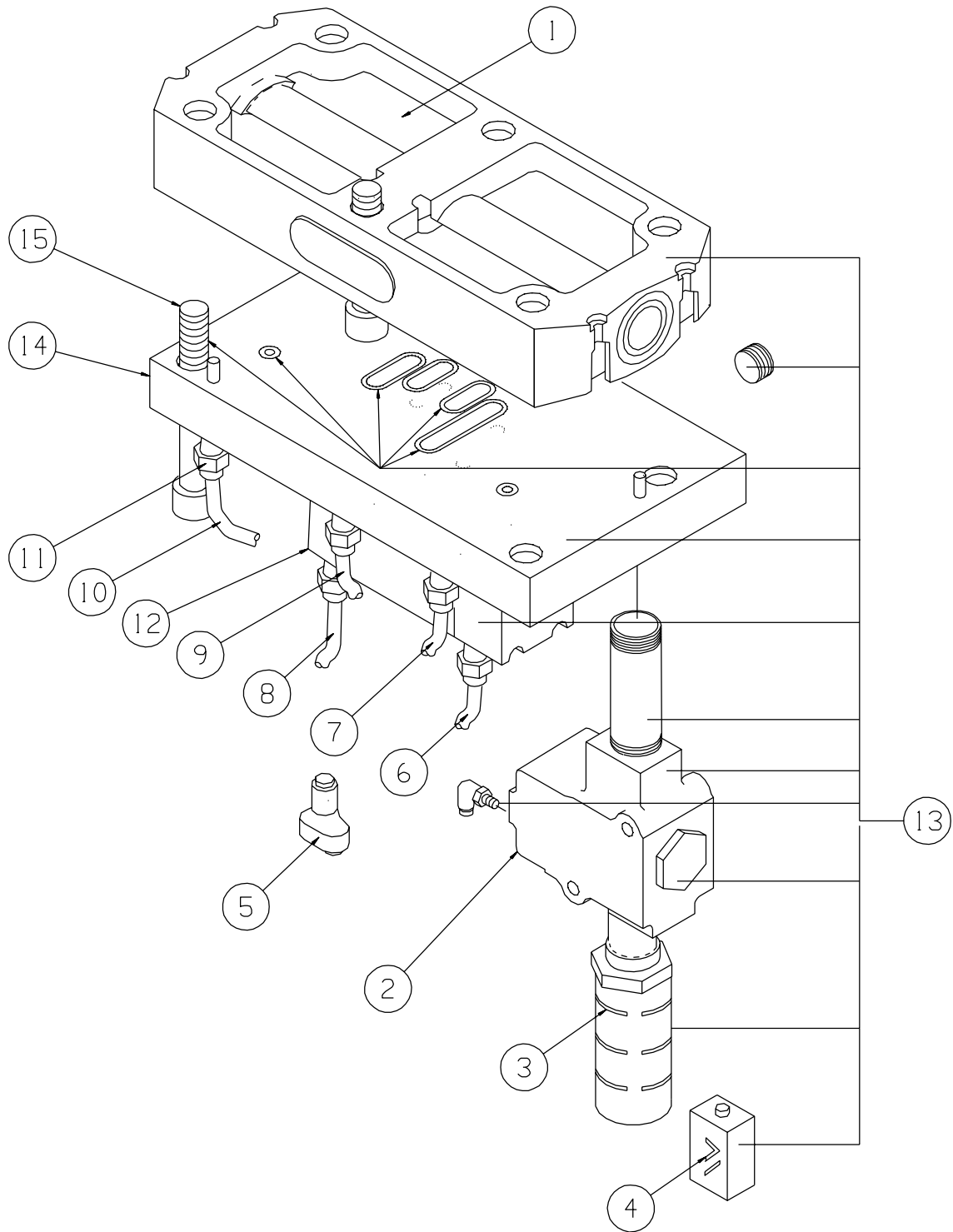

**MIDI DUPLEX INLET HEAD
(midi 31 & 42 l/s)**

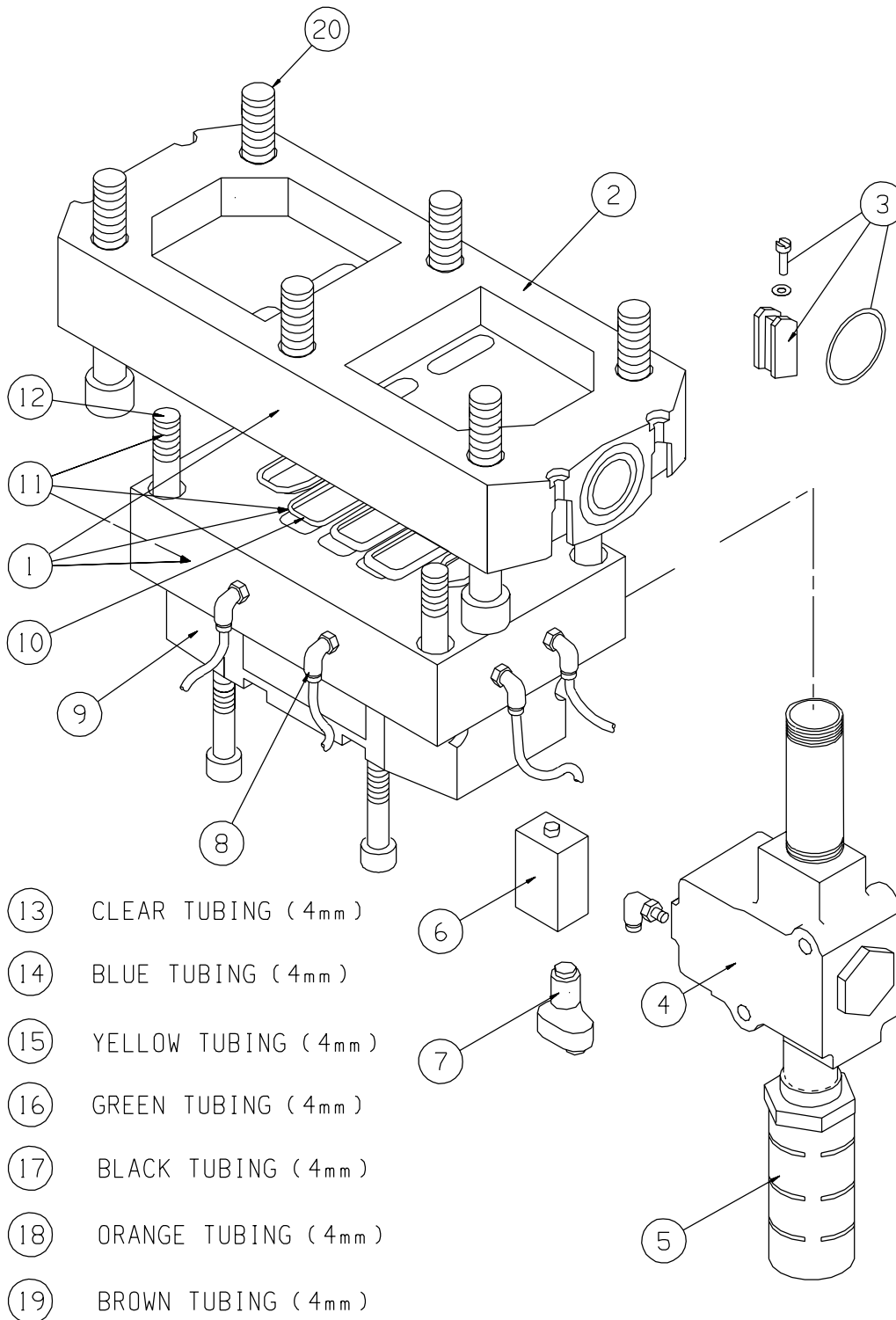



SECTION **A4**

CAM-TIMER REPLACEMENT

A4.1 Mini / Midi

**A4.2 Pressure Gauge Replacement
(Midi Only)**

A4.1 CAM TIMER REPLACEMENT

ISOLATE ELECTRICAL SUPPLY

MINI

Disconnect inlet and outlet pipework and invert dryer, remove base plate, disconnect wires from terminal block and earth wire. Remove cam profile and locating bolts, lift cam motor/gearbox free. To change pilot valve, remove control pipes and screws.

MIDI

Remove control panel from control box. Disconnect pneumatic control pipe from cam-timer and pilot valves. Remove 4 screws from box lid, which will give access to 2 screws holding cam-timer box to the control panel.

A4.2 PRESSURE GAUGE REPLACEMENT (MIDI ONLY)

Remove control panel from control box, disconnect pipe from gauge, remove clamp nut and clamp, remove gauge.

For re-assembly follow reverse procedure

MIDI CAM TIMER ASSEMBLY

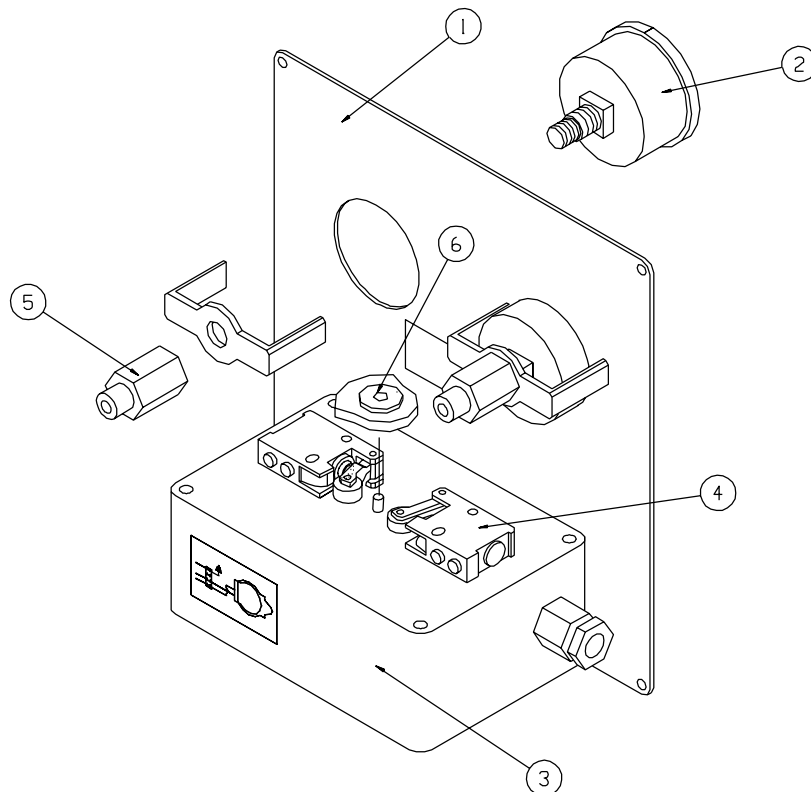

A4.1 PNEUMATIC CAM TIMER REPLACEMENT

ISOLATE SUPPLY

MINI

Disconnect inlet and outlet pipework and invert dryer, remove base plate, disconnect control pipes from control valve. Remove cam profile and locating bolts, lift cam motor/gearbox free. To change pilot valve, remove control pipes and screws.

MIDI

Remove control panel from control box. Disconnect pneumatic control pipes from cam-timer, pilot valves, air motor, prefilter and pressure gauges. Remove locating nuts holding camtimer to fascia plate.

A4.2 PRESSURE GAUGE REPLACEMENT (MIDI ONLY)

Remove control panel from control box, disconnect pipe from gauge, Disconnect pipe adaptor, remove clamp nut and clamp, remove gauge.

For re-assembly follow reverse procedure

PNEUMATIC CAM TIMER ASSEMBLY

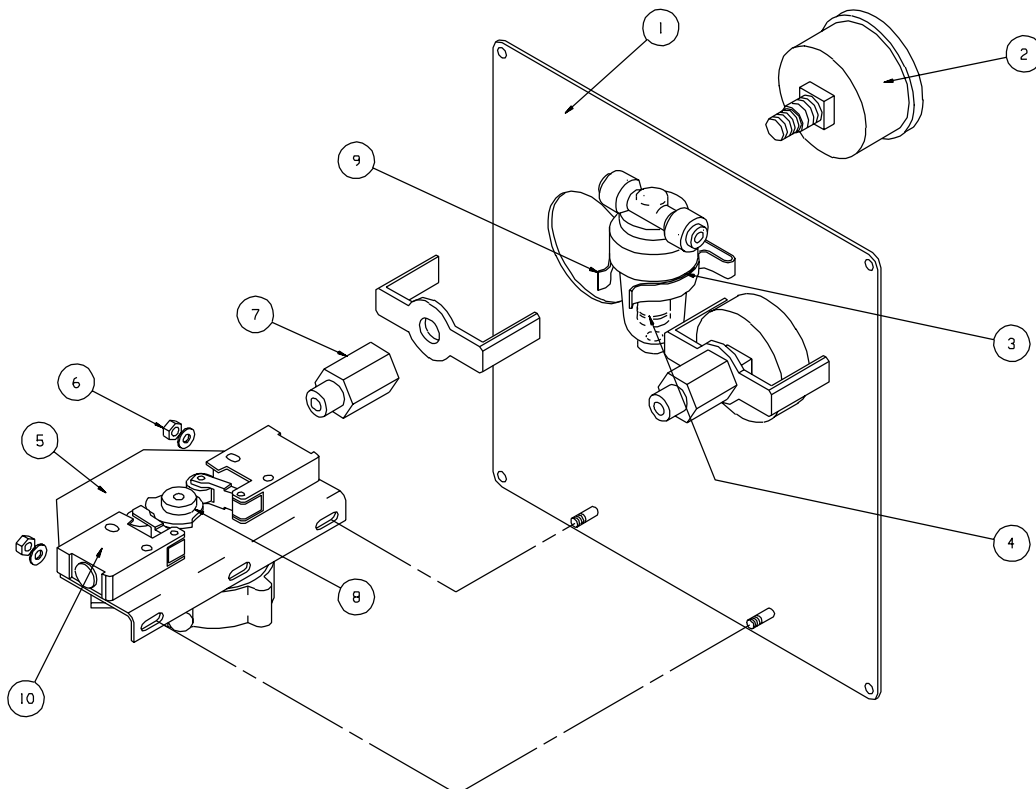

MINI CAM TIMER ASSEMBLY

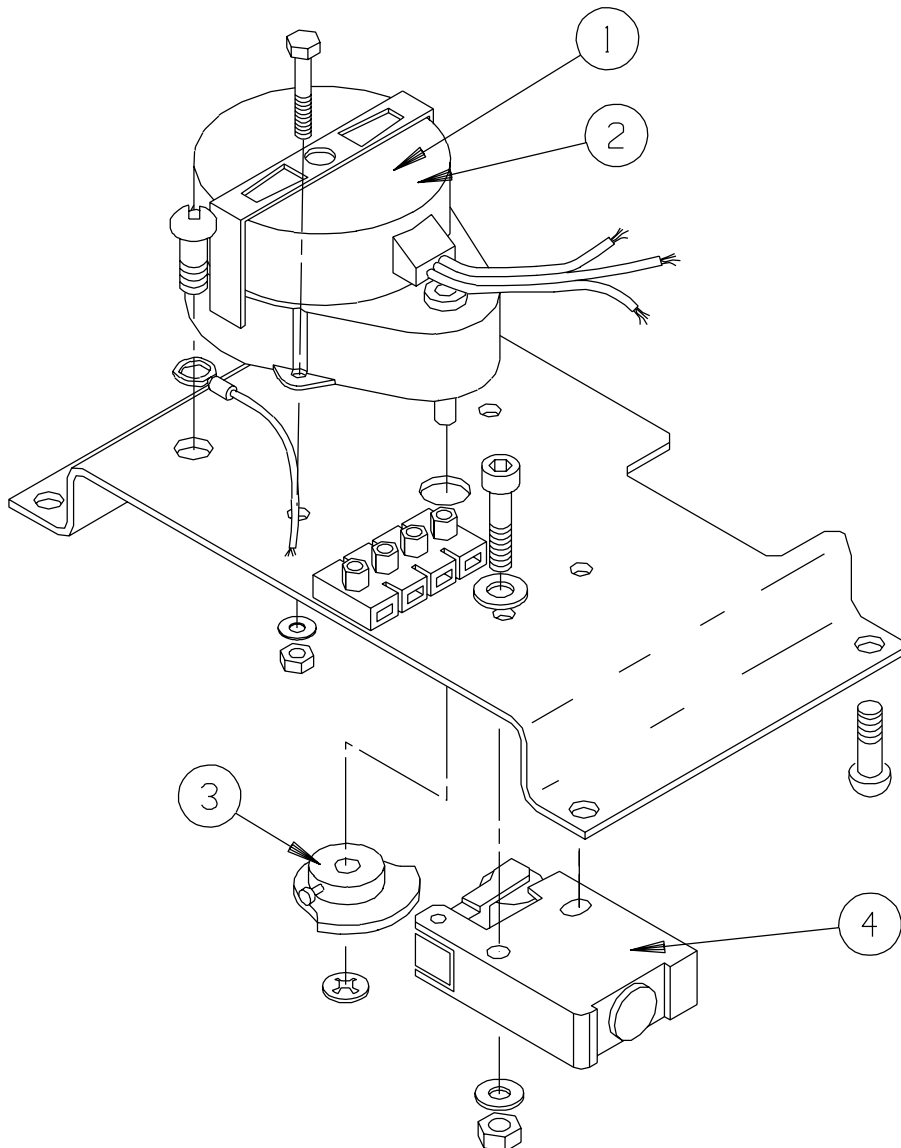

- ⑤ MINI DRYER CAMTIMER KIT 240V
- ⑥ MINI DRYER CAMTIMER KIT 110V
- ⑦ MINI DRYER CAMTIMER KIT PNEUMATIC
- ⑧ MINI DRYER PNEUMATIC MOTOR/GEARBOX KIT

MINI PNEUMATIC CAM TIMER

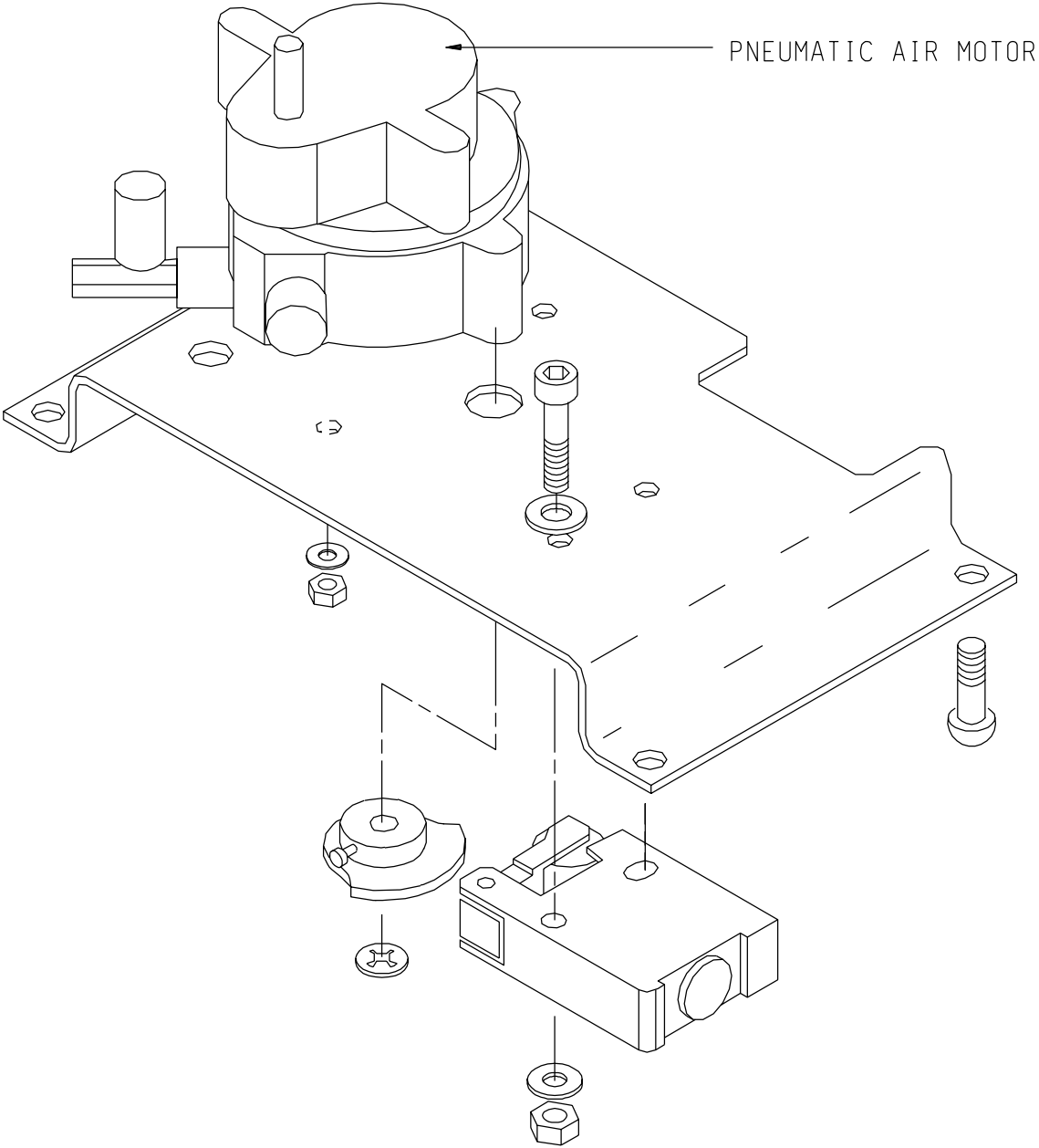



FAULT FINDING GUIDE

MINI / MIDI - FAULT FINDING GUIDE

Problem		Action
1.	Air leaks	<ul style="list-style-type: none"> - Check pipe connections. - Check / change gasket and seals in Inlet & Outlet heads and column.
2.	Continuous exhaust	<ul style="list-style-type: none"> - Inspect check valve discs, springs, valve stems, valves.
3.	Moisture indicator other than blue.	<ul style="list-style-type: none"> - Check air flow through moisture indicator, - Dryer cycle / operation, - Drains for contamination. - Inlet air flow. - Check / change desiccant.
4.	Excessive dust carry over	<ul style="list-style-type: none"> - Check desiccant bed for attrition and change desiccant.
5.	Dryer fails to change over	<ul style="list-style-type: none"> - Check cam timer operation, electrical supply - Check / lubricate control valve. - Check minimum pressure 4 Barg.
6.	Desiccant fails to regenerate	<ul style="list-style-type: none"> - Is dryer changing over ? (see above). - Is dryer being over flowed ? - Pressure too low. - Inlet temp too high. - Check & change desiccant.
7.	Excessive noise on purge.	<ul style="list-style-type: none"> - Check & change silencer.
8.	Pressure gauge not operating	<ul style="list-style-type: none"> - Check signal, if OK change gauge.
9.	Failure to exhaust (MIDI ONLY) Failure to depressurise ?	<ul style="list-style-type: none"> - Check signal from "OR" element. - Check & change exhaust valve. - Check for blocked silencer.



SCHEMATIC DIAGRAMS.

- A6.1 Piping Schematic - MINI**
- A6.2 Piping Schematic**
- A6.3 Piping Schematic (Electric DUPLEX)**
- A6.4 Piping Schematic (Pneumatic MIDI)**
- A6.5 Electric Wiring Diagram (MINI)**
- A6.6 Electric Wiring Diagram (MIDI)**

6.1 - PIPING SCHEMATIC - MINI

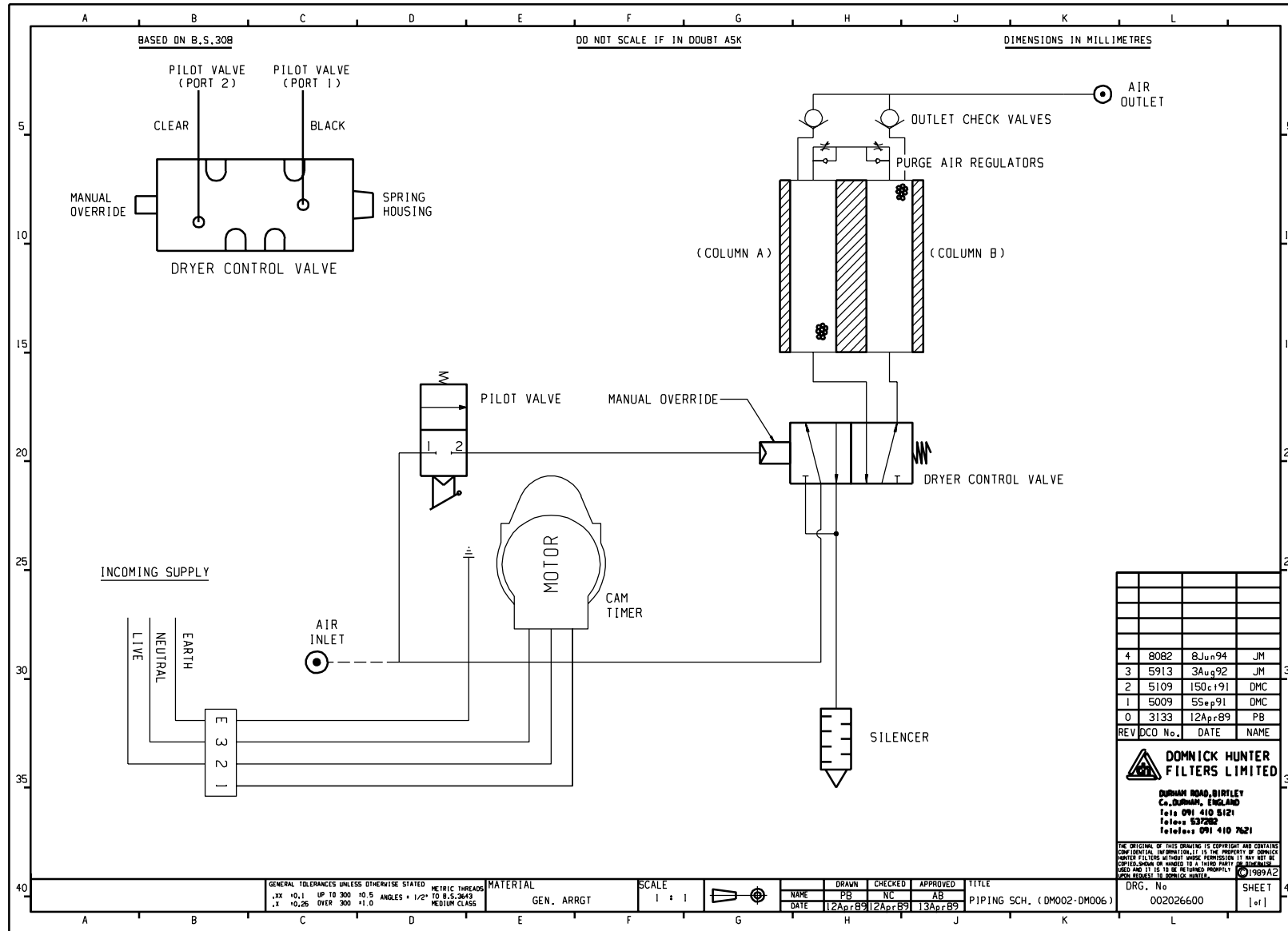

6.3 - PIPING SCHEMATIC (ELECTRIC DUPLEX)

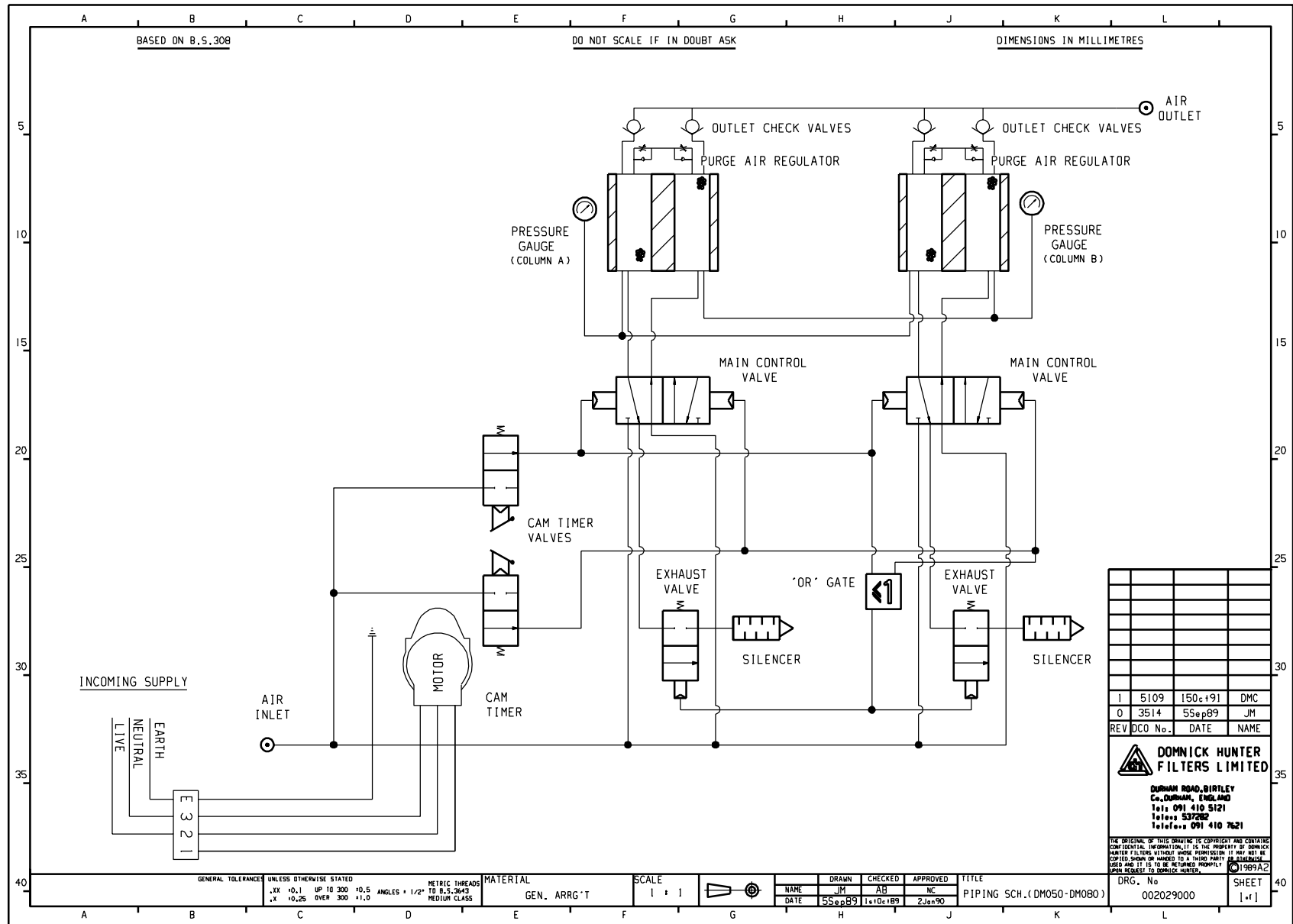

6.4 - PIPING SCHEMATIC (PNEUMATIC MIDI)

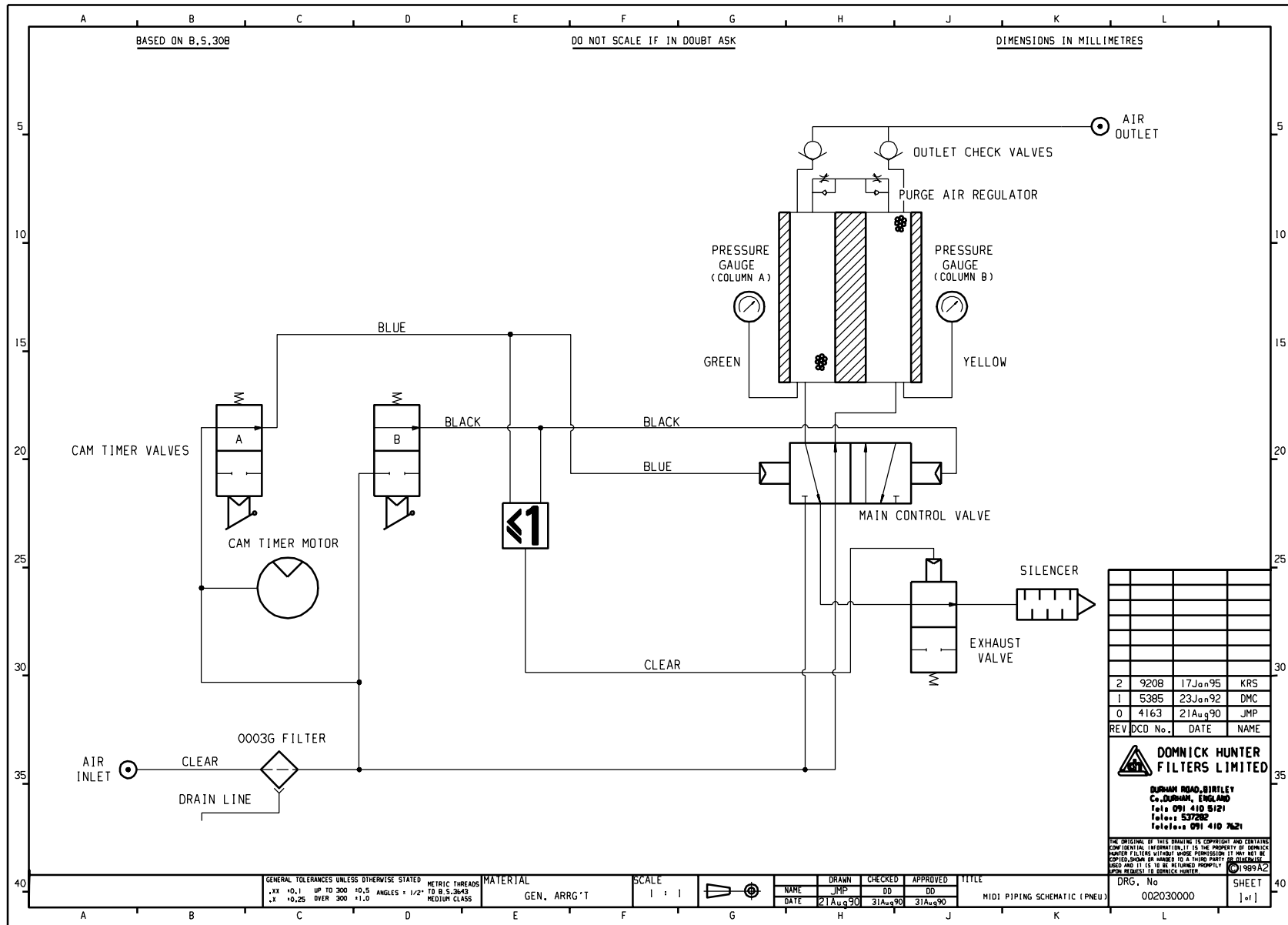

2	9208	17Jan95	KRS
1	5385	23Jan92	DMC
0	4163	21Aug90	JMP
REV	DCD No.	DATE	NAME

DOMNICK HUNTER FILTERS LIMITED
 DURHAM ROAD, BIRTLEY
 Co. DURHAM, ENGLAND
 Telex: 091 410 5121
 Telex: 537282
 Telefax: 091 410 7421

THE ORIGINAL OF THIS DRAWING IS COPYRIGHT AND CONTAINS CONFIDENTIAL INFORMATION. IT IS THE PROPERTY OF DOMNICK HUNTER FILTERS LIMITED. WITHOUT EXPRESS PERMISSION IT MAY NOT BE COPIED, SHOWN OR HANDS TO A THIRD PARTY. FOR CIRCULARS, SEND AND IT IS TO BE RETURNED PROMPTLY. 1989 A2

GENERAL TOLERANCES UNLESS OTHERWISE STATED		METRIC THREADS	MATERIAL	SCALE	DRAWN	CHECKED	APPROVED	TITLE	DRG. No	SHEET
.XX	+0.1	UP TO 300	+0.5	ANGLES = 1/2"	TO B.S.2843	DD	DD	MIDI PIPING SCHEMATIC (PNEU)	002030000	[+]
.X	+0.25	OVER 300	+1.0	MEDIUM CLASS	GEN. ARR'G'T	DD	DD			
NAME	JMP	DD	DD	DATE	21Aug90	31Aug90	31Aug90			

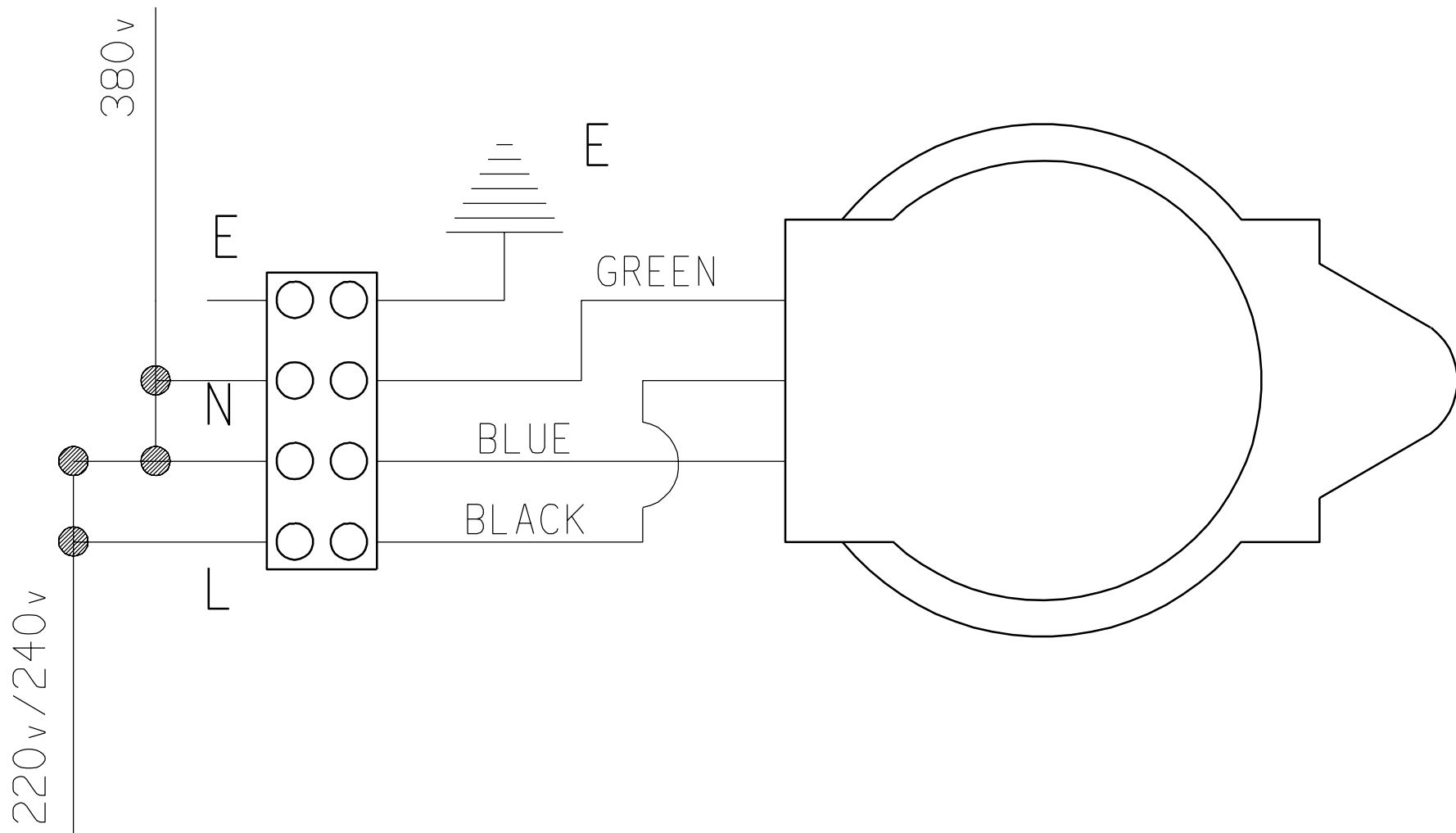

220/380v WIRING DIAGRAM- ELECTRIC CAM TIMER (MINI)

It can be used as 220v or 380v.

For 220v connect the BLUE wire to a neutral supply, and the BLACK wire to a 220/240v supply. Insulate the GREEN.

For 380v connect the BLUE and GREEN across any two phased and insulate the BLACK.

