

# Installation, Operations & Maintenance Manual

## *N2-GEN™*

*N2-Gen™-4 Model*

### *Nitrogen Generator*



**THIS PUBLICATION IS REQUIRED FOR OFFICIAL USE OR FOR ADMINISTRATIVE OR OPERATIONAL PURPOSES. DISTRIBUTION IS LIMITED TO U.S. GOVERNMENT AGENCIES ONLY. OTHER THAN FOR UNCLASSIFIED LIMITED DOCUMENTS, DESTROY BY ANY METHOD THAT WILL PREVENT DISCLOSURE OF CONTENTS OR RECONSTRUCTION OF THE DOCUMENTS.**

## 1.1

### SAFETY SUMMARY

#### **Warning**

**Do not puncture any part of the Nitrogen Storage Tank; pressurized gas could burst the vessel and cause personal injury or death.**

**Do not remove, cut or work on any hose inside or outside the Nitrogen Generator or Tank without cutting off the power or turning off preinstalled valves**

**Do not expose any pressurized vessel to excessive heat or fire; expanding gas could result in a vessel or hose burst. There are safety valves installed at 150psi bursting pressure to keep pressures below all burst levels.**

#### **Warning**

**Pure Nitrogen is being produced by the Nitrogen Generator and can cause asphyxiation if inhaled directly. Always use in a well-ventilated area with caution.**

**If headache or “light-headed” feelings occur, quickly move to a new room or outside. Ventilate the area and check for leaks. Contact POC if necessary.**

#### **Warning**

**System requires 110VAC up to 8Amps and is not intended for use with or around liquids.**

**Note all electrical warnings and do not reroute, tap into, or change out any electrical component or wire for non-manufacturer parts.**

<b>LIST OF FIGURES</b> .....	<b>4</b>
<b>LIST OF TABLES</b> .....	<b>6</b>
<b>CHAPTER 1</b> .....	<b>7</b>
<b>1.1 Introduction</b> .....	<b>7</b>
<b>1.2 Important Information</b> .....	<b>7</b>
<b>1.3 Unpacking and Preparations</b> .....	<b>8</b>
<b>CHAPTER 2</b> .....	<b>9</b>
<b>2.1 Installation Guidelines</b> .....	<b>9</b>
<b>2.2 Mounting the N<sub>2</sub>-GEN</b> .....	<b>9</b>
<b>NOTE:</b> .....	<b>9</b>
<b>2.3 Panel Layout and Gas Connections</b> .....	<b>12</b>
<b>2.4 N2-GEN™ Layout Diagram</b> .....	<b>13</b>
<b>2.5 Powering Up the N2-GEN™</b> .....	<b>14</b>
<b>2.6 Leak Checking</b> .....	<b>14</b>
<b>CHAPTER 3</b> .....	<b>16</b>
<b>3.1 Preventative Maintenance (PMCS)</b> .....	<b>16</b>
<b>CHAPTER 4</b> .....	<b>20</b>
<b>BlastOff™ - Leak Detection System</b> .....	<b>20</b>
<b>Appendix A - N2-GEN™ Specifications</b> .....	<b>21</b>
<b>Appendix B - N2-GEN™ Part Identification and Parts List</b> .....	<b>22</b>
<b>Internal Sub-Assemblies and Locations</b> .....	<b>23</b>
<b>Appendix C - Troubleshooting</b> .....	<b>29</b>
<b>Appendix D – Wiring Diagram</b> .....	<b>31</b>
<b>Appendix E – Warranty - POC</b> .....	<b>32</b>
<b>Sub-Assembly Replacement Instructions</b> .....	<b>33</b>

# LIST OF FIGURES

<i>(FIGURE 2-2a)</i> .....	9
<i>(FIGURE 2-2b)</i> .....	11
<i>(FIGURE 2-3)</i> .....	12
<i>(FIGURE 2-4)</i> .....	13
<i>(FIGURE 3-1b)</i> .....	17
<i>(FIGURE 3-1a)</i> .....	17
<i>(FIGURE 3-1f)</i> .....	18
<i>(FIGURE 3-1e)</i> .....	18
<i>(FIGURE 3-1d)</i> .....	18
<i>(FIGURE 3-1c)</i> .....	18
<i>(FIGURE 3-1g)</i> .....	19
<i>(FIGURE 3-1i)</i> .....	19
<i>(FIGURE 3-1h)</i> .....	19
<i>(FIGURE B-1)</i> .....	22
<i>(FIGURE B-2)</i> .....	23
<i>(FIGURE B-4)</i> .....	23
<i>(FIGURE B-3)</i> .....	23
<i>(FIGURE B-5)</i> .....	24
<i>(FIGURE B-7)</i> .....	24
<i>(FIGURE 4-3f)</i> .....	24
<i>(FIGURE B-8)</i> .....	25
<i>(FIGURE D-1)</i> .....	31
<i>(FIGURE E-3)</i> .....	34
<i>(FIGURE E-2)</i> .....	34
<i>(FIGURE E-1)</i> .....	34
<i>(FIGURE E-4)</i> .....	34
<i>(FIGURE E-5)</i> .....	34
<i>(FIGURE E-7)</i> .....	34
<i>(FIGURE E-6)</i> .....	34
<i>(FIGURE E-9)</i> .....	34

<b>(FIGURE E-8)</b> .....	<b>34</b>
<b>(FIGURE E-11)</b> .....	<b>34</b>
<b>(FIGURE E-10)</b> .....	<b>34</b>
<b>(FIGURE E-12)</b> .....	<b>34</b>
<b>(FIGURE E-13)</b> .....	<b>34</b>
<b>(FIGURE E-14)</b> .....	<b>34</b>
<b>(FIGURE E-15)</b> .....	<b>34</b>
<b>(FIGURE E-16)</b> .....	<b>34</b>

**LIST OF TABLES**

*(TABLE A-1)* ..... 21  
*(TABLE B-1)* ..... 22  
*(TABLE B-2)* ..... 26  
*(TABLE B-2) cont.* ..... 27  
*(TABLE B-2)cont.* ..... 28  
*(TABLE B-3)* ..... 28  
*(TABLE C-1)* ..... 29

# CHAPTER 1

## 1.1 Introduction

The N<sub>2</sub>-GEN™ provides an economical, precise means of generating high purity Nitrogen. South-Tek System's lines of N<sub>2</sub>-GEN™ products consist of an internal a) N<sub>2</sub> generator and b) air compressor. Since air is comprised of 79% N<sub>2</sub> we simply and cost-effectively separate the N<sub>2</sub> from the air. Nitrogen is an inert gas (non-combustible), which is even used to package food products for increased shelf life. The N<sub>2</sub> is "generated" by means of the air compressor pushing air into the simple, safe membrane element, which in turn mechanically separates N<sub>2</sub> molecules from other molecules found within air.

\*\*The installer and the user should read this manual in its entirety.

## 1.2 Important Information

***\*\*\* Read before installing and operating the N<sub>2</sub>-GEN™ \*\*\****

All personnel (and their supervisors) installing, operating, and maintaining the *N<sub>2</sub>-GEN* must read and fully understand this manual prior to installing, operating or performing maintenance on the system.

The *N<sub>2</sub>-GEN* produces Nitrogen (N<sub>2</sub>) at a low flow rate, which quickly dissipates into the air. N<sub>2</sub> gas is not poisonous but the gas should not be directly inhaled, since in high concentrations, can cause asphyxiation. Ensure that the unit is installed within a well-ventilated room, one that is not sealed off from normal living space air changes.

All personnel involved with installation, operations, and maintenance of the *N<sub>2</sub>-GEN* must follow safe working practices, OSHA, and local health/safety code regulations during the installation, operation, and maintenance of the unit.

**Electrical Requirements:** Connect the *N<sub>2</sub>-GEN* to an electrical supply following all local safety regulations. Ensure the unit is supplied with 110V/60hz power rated at 20-amp service. Ground electrical when available.

**Servicing the *N<sub>2</sub>-GEN*.** Before personnel attempt to service the unit, ensure the power switch has been turned to the off position, then disconnect the unit's external power cord from the electrical power supply.

### **1.3 Unpacking and Preparations**

The *N<sub>2</sub>-GEN* System's carton should be carefully opened and all parts should be inspected for damage, upon receipt. Identify and verify that all parts listed on the packing list are present and undamaged. If there are parts missing contact South-Tek Systems immediately. If the package(s) is damaged or has been opened, also contact the shipping company. *South-Tek Systems (STS) insures all packages through the shipping company and is not responsible for damages that may occur during shipping and handling of the N<sub>2</sub>-GEN.* If there are any visual damages, immediately document and report the damages to the shipping company responsible or refuse the shipment. Then contact STS at (888) 526-6284 to assess the damages only after the shipping company has been notified.

#### **Until Installation:**

- When at all possible, store the *N<sub>2</sub>-GEN* in a dry and climate controlled (50-80°F) area.
- Always keep the *N<sub>2</sub>-GEN* in an upright position.
- Do not connect the AC power cable until this manual has been read completely and all connections are made as stated within.
- Keep all gas lines dry so you don't get the moisture in the generator upon hookup.
- Never place/stack objects on top of the *N<sub>2</sub>-GEN*.



## CHAPTER 2

### 2.1 Installation Guidelines

It is necessary to use caution when working with pressurized gas, making sure that all fittings and gas lines are installed correctly. Always leak check every line before using the system. **Note:** Line leaks will cause the N2-GEN™ to run excessively, shortening its life.

Never detach a line with pressure on it before closing provided valves, you could cause damage to the equipment or bodily injury.

Install the N2-GEN™ in a solvent free environment. Solvents can breakdown the filtration and Nitrogen producing media. If cleaning the unit, power down the unit while cleaning and use alcohol or similar to clean components. Do not spray solutions into the inside of the cabinet, apply to a towel and clean if necessary. Spraying solvents or other around the cabinet while in operation can damage internal components since the N2-GEN™ has an intake fan and uses surrounding air to work.

### 2.2 Mounting the N<sub>2</sub>-GEN

The N<sub>2</sub>-GEN can be mounted to a wall or placed on a floor. It is recommended that the N<sub>2</sub>-GEN be mounted to a weight-bearing wall that can support its weight as specified in Appendix A. If placed on a floor, it should still be fastened in place so that it cannot move due to vibration or be damaged from falling over. The N<sub>2</sub>-GEN should always be installed indoors in an environment between 35° and 90° F in the upright position where it will not be damaged by water or moving equipment. Make sure that the N2-GEN™ has access to a 110VAC 20AMP power outlet.

There is an optional mounting bracket kit shown, that allows you to mount the system on a standard 16" wall stud width. Otherwise, use the mounting holes on the cabinet for mounting the N2-GEN™ securely and upright, directly to the wall.

#### **NOTE:**

Ensure the wall can support the N2-GEN™ weight (75lbs min).

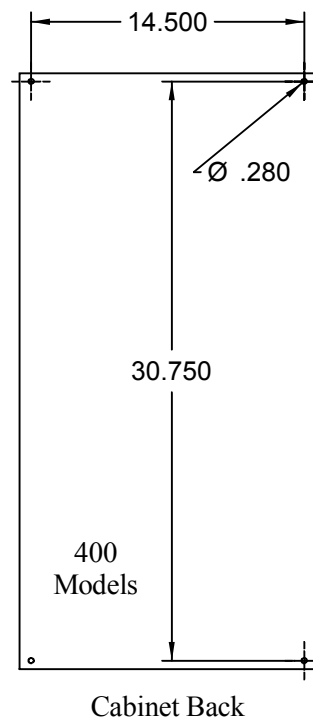

(FIGURE 2-2a)

**Optional Mounting Bracket Kit Procedures:**

1. All N2-GEN™ mounting holes and optional mounting bracket holes are for ¼” screws/anchors).
2. All the brackets must be installed in the orientation as shown, to work correctly.
3. Install the cabinet-mounting bracket on the N2-GEN™ first with the bolts/lock nuts that are provided. The bracket to be attached to the N2-GEN™ should have the inner holes (that mount to the cabinet) on the top. The holes that will be mounted to the wall should be on the bottom.
4. Install the wall-mounting bracket on the wall at the desired height as shown in figure 2.
  - a. The width between the holes on the outside of the mounting bracket is 16” (for 16” stud centers).
  - b. Use the appropriate screws (wood, sheet metal, masonry, etc.) and make sure that you are drilling them into the studs or wall materials capable of supporting the N2-GEN™ weight as specified in Appendix A.
5. Once the mounting bracket is firm on the wall, hang the N2-GEN™ cabinet from the top bracket making sure it is centered.
6. Finally, the bottom bracket should then be screwed into the wall so the N2-GEN™ cannot slide from side to side.

## WARNING

Secure the N2-GEN™ to the wall at the top and bottom flanges. Failure to do so could cause damage or bodily injury.

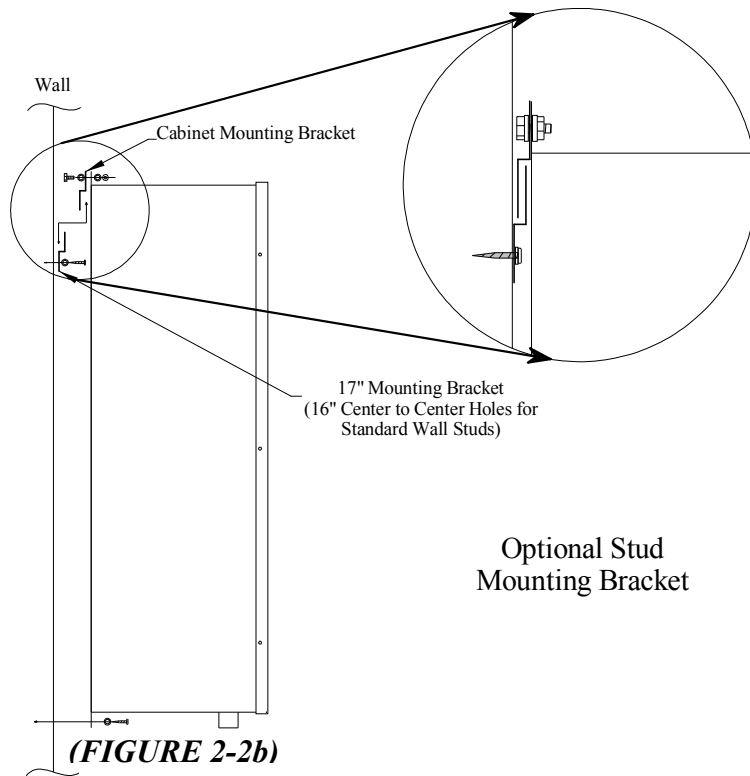

### **2.3 Panel Layout and Gas Connections**

All gas connections will be made on the left hand side of the cabinet. Double-check all connection locations before turning on the system or opening any valves.

**NOTE:**

All N2-GEN™ models are factory equipped with ¼”NPT Female connections.

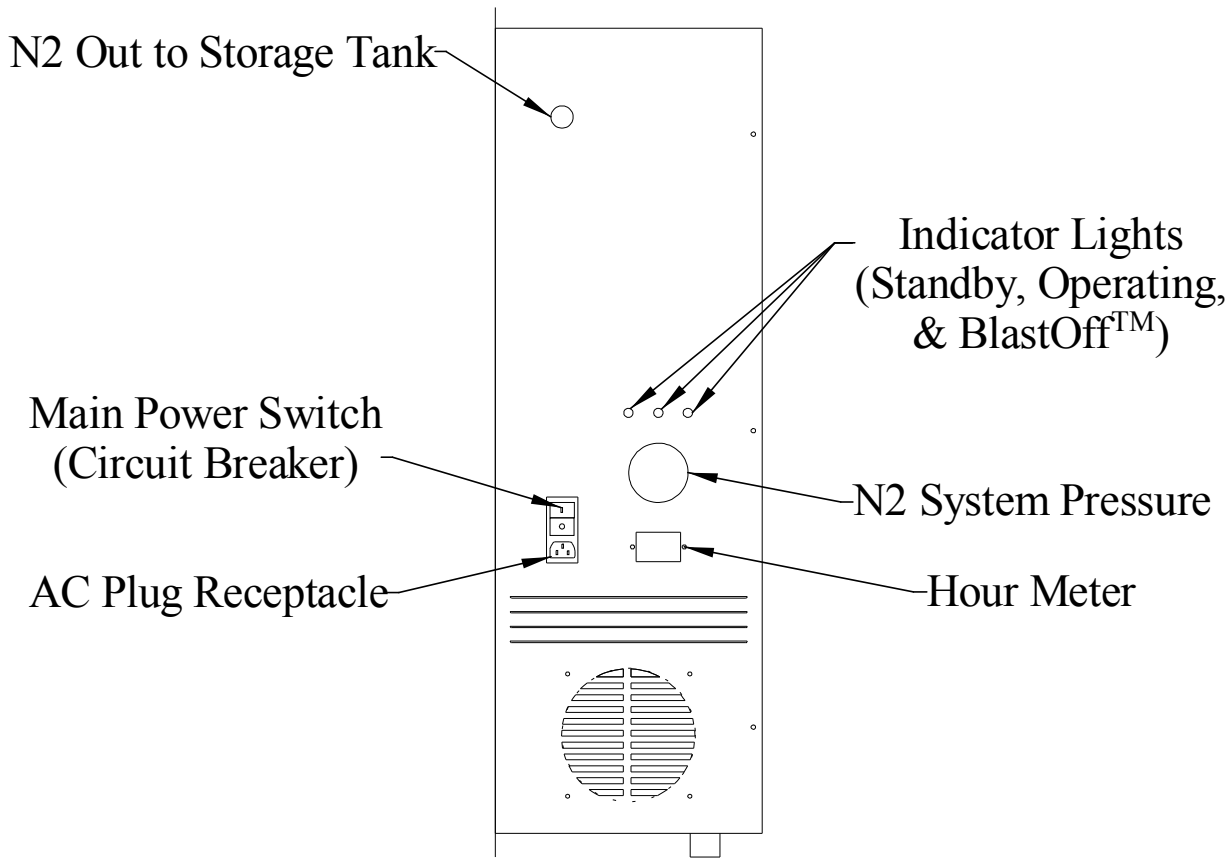

**(FIGURE 2-3)**

## 2.4 N2-GEN™ Layout Diagram

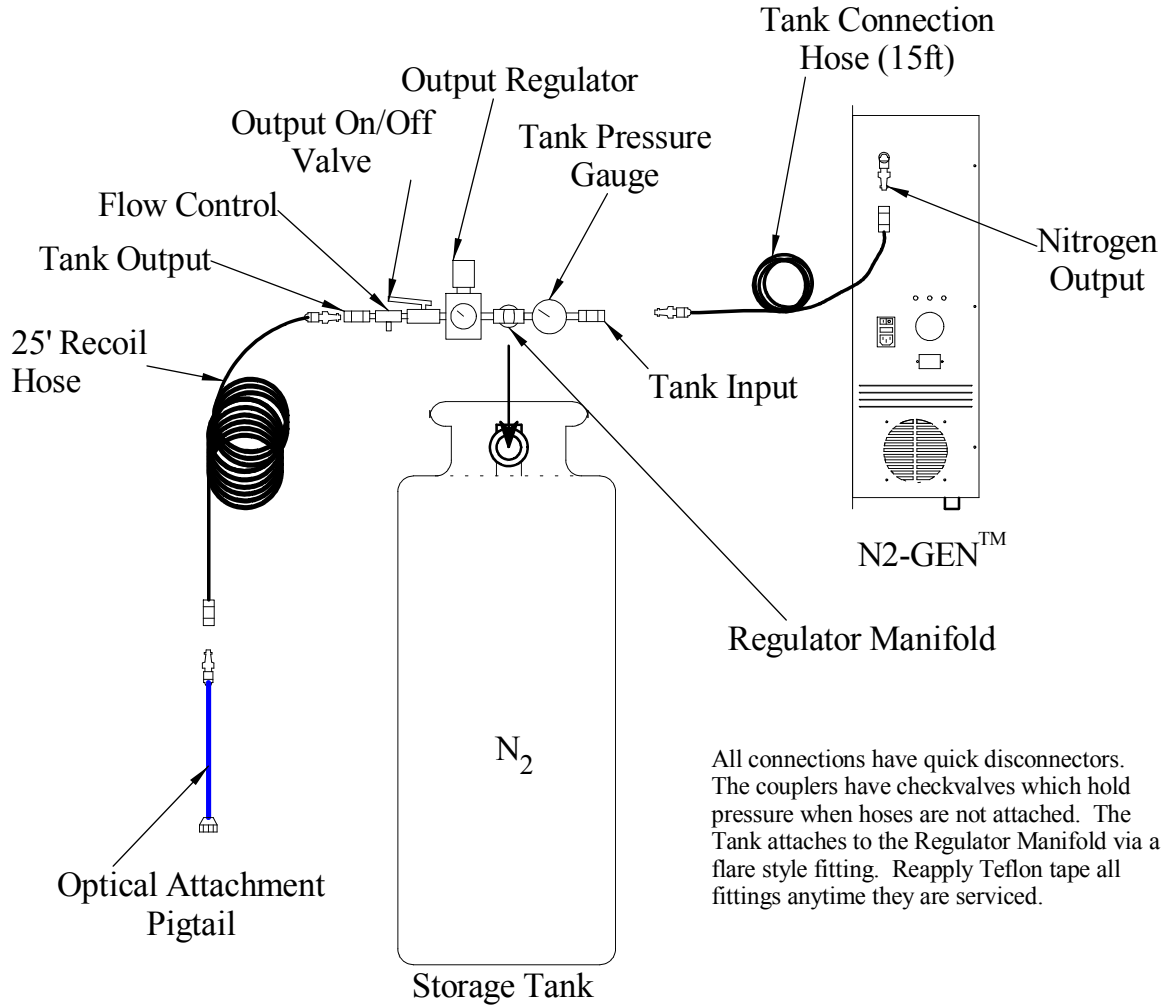

All connections have quick disconnectors. The couplers have checkvalves which hold pressure when hoses are not attached. The Tank attaches to the Regulator Manifold via a flare style fitting. Reapply Teflon tape all fittings anytime they are serviced.

**(FIGURE 2-4)**

## **2.5 Powering Up the N2-GEN™**

Your system is shipped ready for power once you connect your hose. Connect your application tubing or hose to the storage tanks outlet using Teflon tape. All valves should be open and ready for gas to be distributed. Plug your N2-GEN™ into an 110VAC power outlet and turn on the rocker switch. Your system's compressor will come on if the N<sub>2</sub> storage tank is not already pressurized. If it is at or above the specified pressure, you will see the "Standby" light illuminated. Once you drop below that pressure, your compressor will activate and generate the N<sub>2</sub> necessary to maintain system gas requirements. The "Operating" light will illuminate until the N<sub>2</sub> storage tank pressure reaches maximum (approximately 100 PSI for the N2-GEN™-4) and the compressor shuts off.

## **2.6 Leak Checking**

### **2.6.1 To leak check the N2-GEN™:**

1. Turn the storage tank output valve to the off position.
2. Using the 15' Tank Connection Hose, connect the Nitrogen Output of the N2-GEN™ to the Output of the storage Tank.
3. Turn the system power on. The system's compressor should start and the system's N<sub>2</sub> pressure will begin to build. The system pressure should build to 100psi. The system should go into stand-by mode and the compressor should stop.
  1. If the pressure holds in stand-by mode for a minute, then your N2-GEN™ is working properly and there appear to be no leaks inside the unit.
  2. If the pressure doesn't hold and the system goes back into operation, then check for leaks at the output connection, and all external fittings. If you can't find a leak, contact the POC.
  3. If the N2-GEN™ never goes into stand-by mode, check for external leaks and retry. If no leak is found, then the leak is internal. Open the cabinet and try to locate the internal issue. Contact the POC for guidance if the issue isn't obvious.
    - a. To open cabinet, there are 6 (10x32 –0.5") screws to remove on the front cabinet cover. Remove and set to side.
    - b. The compressor may be hot, use caution. Do not spray soapy water (leak detector solution) inside the cabinet.
    - c. Looking for obvious leaks, feel around the hoses and try to find either a leaking fitting or a cut/unconnected hose.
    - d. If you don't feel or see the obvious issue, contact POC for help.
    - e. If you find the leak and need to replace a defective part, contact POC for factory parts. If it is something you can repair, always use factory replacements (instructions supplied with parts) and Teflon tape (or similar) all brass fittings.
4. Reattach the Tank Connection Hose to the input of the tank and power up the system to begin use or to charge the storage tank.

### **2.6.2 To leak check the Storage Tank:**

1. Connect the N2-GEN™ to the tank input with the provided hose. Turn the N2-GEN™ power on to allow the tank to begin filling with nitrogen.

2. Turn the Tank Output Valve to the off position.
3. Once it reaches the storage pressure (100psi) and the system will go into stand-by mode.
  - a. If there is a slow leak in your regulator manifold, the compressor will cut on and start to refill the tank after a few min/sec. Disconnect the outlet hoses and make sure all connections are Teflon taped and tight. Use a leak check solution (soapy water) to see if you find a leak on the manifold. Correct leak.
  - b. If the system never reaches Stand-by Mode
    - i. Use leak check solution to check the regulator manifold
    - ii. Recheck the N2-GEN™ for a leak as described previously (2.6a) if not just verified.
    - iii. Contact POC

### **WARNING**

- **If your compressor remains on and your system's N<sub>2</sub> pressure never reaches the specified level, double check for leaks, then contact POC.**
- **If your compressor remains on and the N<sub>2</sub> pressure is more than 105psi, power off the system immediately and consult your POC.**
- **If the compressor is not running and you are more than 10psi under the specified N<sub>2</sub> pressure (100psi), make sure you have power, then call POC.**

## CHAPTER 3

### **3.1 Preventative Maintenance (PMCS)**

The N2-GEN™ contains 3 filters that need to be changed out regularly. **All filters should be changed out every 4 months or 250 hours of runtime whichever comes first** (there is a hour meter on the side panel).

#### **Electronic Filter Service Indicator**

The N2-GEN™ is equipped with a Filter that has an Electronic Service Indicator built-in. This can be used in the case of prolonged storage or when being used in a harsh environment. The Service Indicator can be used in conjunction with the filter change out schedule above. If the “FilterSvc” indicator illuminates and remains on, then the filter is saturated and all filters need to be changed immediately. Note: the light might come on briefly and turn off while the system is coming up to pressure (<5mins). If it remains on, perform the PMCS. Do not use system with old filtration. The Nitrogen Producing Media can be damaged beyond repair quickly.

#### **Changing the Filters**

1. Disconnect the power before servicing the unit.
2. Remove the cover.
3. Locate the 3 filters (shown in photos)
  - a. Pre-compressor filter, located on the top of the compressor.
  - b. General Purpose filter, on the right side, clear bowl, closer to the cabinet back, pinkish filter element.
  - c. Coalescing filter, on the right closest to the front of the unit, green filter element
4. Remove the pre-compressor filter cap by twisting clockwise. Remove the old filter and replace with the new one.
5. Remove the filter bowls on the General Purpose and Coalescing filters by pushing up on the bowls and twisting counter-clockwise 1/8 of a turn, then it will pull straight down.
  - a. Note: there is a rubber o-ring that may or may not come out with the bowl, if it does, make sure to reseal it before putting the bowl back on.
  - b. Remove the filter cartridges by unscrewing them from the housing. Replace with the new cartridges and reinstall the bowl. Make sure the pinkish filter goes in the rear filter and the green filter goes in the front just as they were removed.
6. Reinstall the filter bowls. Make sure the floats that are inside the bowls are in place when you reinstall the bowls. The system won't work without the auto-drain floats. See photos.
7. Reconnect the power and turn the system on. If the storage is full, you can relieve some of the pressure by pulling the Safety relief ring inside the unit in the upper left corner. Once the pressure drops a few pounds, the unit should cut back on. Feel and listen for any leaks on the filters.
8. Once satisfied that they are on tight and sealed; replace the cover and allow the storage to top fill up.



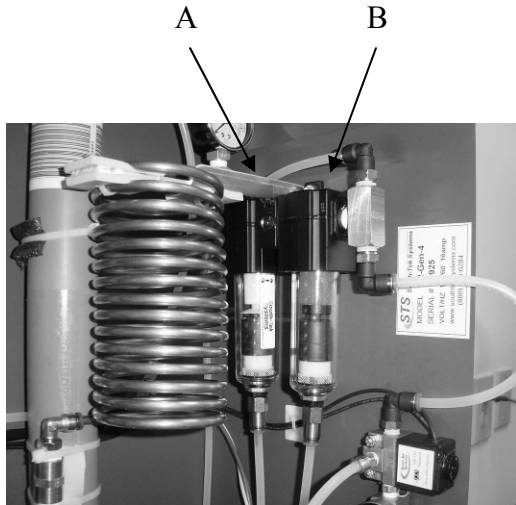

**(FIGURE 3-1a)**

- A- General Purpose Filter
- B- Coalescing Filter



**(FIGURE 3-1b)**

Take off the Coalescing Filter Bowl, push up, turn counter-clockwise, pull down.



(FIGURE 3-1c)

Remove the green coalescing filter by unscrewing.

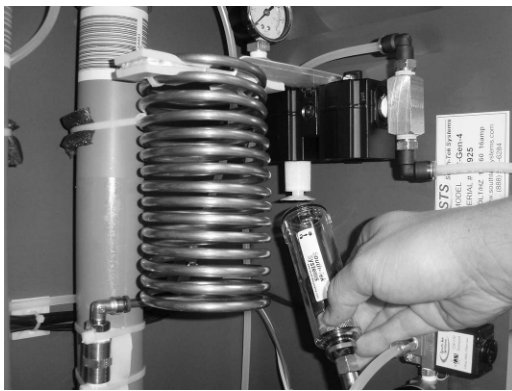

(FIGURE 3-1d)

Remove the general purpose Filter bowl.

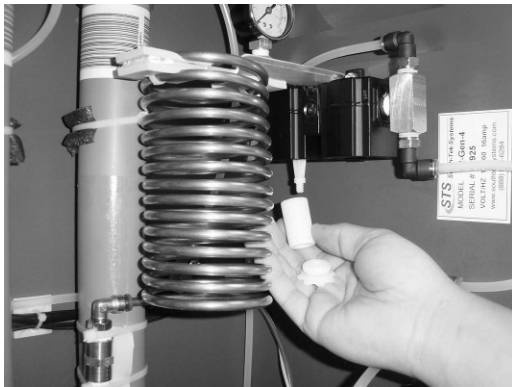

(FIGURE 3-1e)

Unscrew the general purpose filter and replace with new filter.



(FIGURE 3-1f)

Inside the bowls, there are auto drain floats. Make sure they are put back into the bowl if they come out.

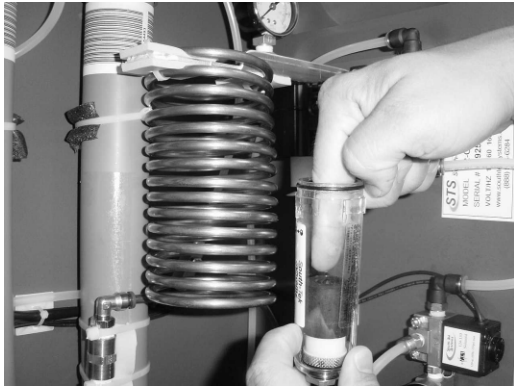

(FIGURE 3-1g)

The float should seat all the way to the bottom of the bowl before reinstalling the bowls. Make sure the new filter cartridges are installed before putting the bowls back on.



(FIGURE 3-1h)

Turn the pre-compressor cover clockwise to remove.



(FIGURE 3-1i)

Remove and replace the filter cartridge, reinstall the cover.

## CHAPTER 4

### BlastOff™ - Leak Detection System



The BlastOff™ – Leak Detection System is a Patented system when installed into a N2-GEN™ will detect line leaks downstream or within the N2-GEN™. Line leaks could be due to a cut hose, a leaking fitting, etc. These leaks are potential safety hazards, they can cause the N2 to deplete quickly, and could cause your N2-GEN™ system to run in excess (decreasing the life of the unit).

Once a leak has been detected, the BlastOff™ is factory set to initiate a buzzer, activate a red warning light (inserted into the N2-GEN™ cabinet), and shut off the N2-GEN™ until the problem has been remedied. To reset the BlastOff™, simply turn off the N2- GEN™ power switch and turn it back on. The N2-GEN™ can be ordered with the BlastOff™ System Factory installed or the system can be retrofitted in the field. Some rewiring and drilling required to field install.

Factory settings will give both an audible and visual alarm as well as shut the compressor down. The buzzer and light will continue until the system has been reset . Never reset over and over, if the BlastOff™ goes off, there is a real potential issue. Consult your installer or the factory for a solution.

The label below and the Logo above will be on your N2-GEN™ if factory installed.

### **WARNING**

This unit is equipped with **The BlastOff™ - Leak Detection** feature. If the red light and buzzer are on, you may have a leak in one of the gas line. **Note:** Turn off this unit's on/off rocker switch and check for leaks. If none are found, leave the unit turned off and contact your service company. Only once the leak located and corrected should you resume normal operation. This is a safety feature designed to provide a safer operating environment. To reset the BlastOff™, turn the system off for 10 seconds, and then resume operation.

## Appendix A - N2-GEN™ Specifications

	<u>N2-GEN™-4</u>
Nitrogen purity	98.5% +/- .2
Mounting	tank, wall, or floor
Display	Hours/Power on/Operating
N <sub>2</sub> Storage Pressure	100 psig
Output	10 lpm
Cabinet Port Connections	¼ “ NPT Female
Electrical	110 VAC; 20 Amp breaker
Compressor	Integral / Oil-free
Ambient Temperature	35 to 90°F
Noise level (dbA)	under 80
Size	32”H x 12”W x 11”D
Weight	75 lbs

**(TABLE A-1)**

## Appendix B - N2-GEN™ Part Identification and Parts List

- Only use factory parts in the N2-GEN™ Nitrogen Generator. Substitute parts may be inferior and cause damage to your system.
- Warranty may be void if factory replacement parts are not used.

	STS Part #	Description
A	124-305	¼" Nitrogen Output
B	124-215	Terminal Strip
C	124-190 amber 124-195 green 124-196 red	Indicator Lights
D	124-120	1.5" Pressure Gauge
E	400-133	Power Switch/Fuse
F	124-185	Hour Meter
G	124-160	Axial Fan

(TABLE B-1)

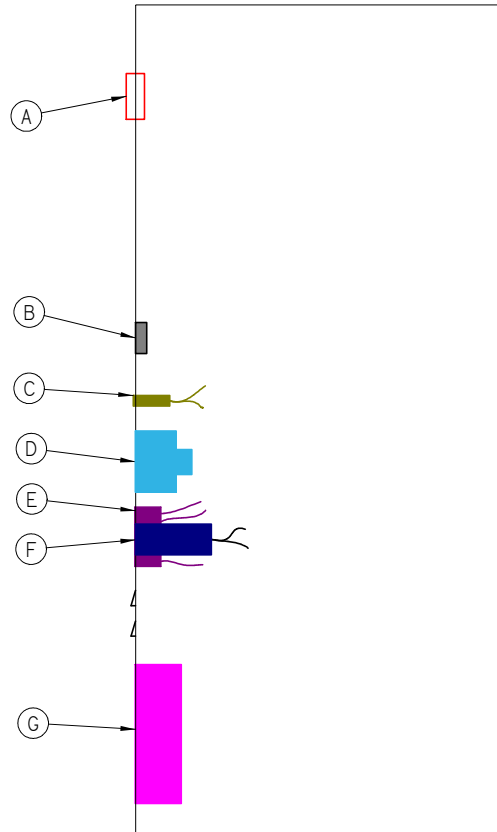

(FIGURE B-1)

## Internal Sub-Assemblies and Locations

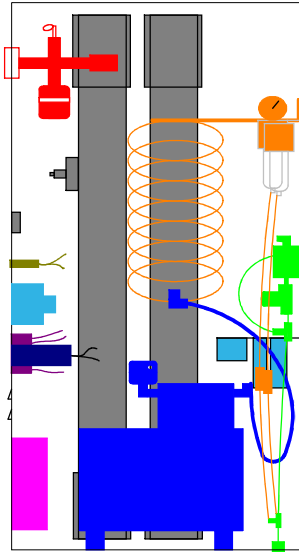

Complete System  
(FIGURE B-2)

**\*Sub-Assemblies are replaced as one part.**

**800-540  
N2-GEN™-4 Compressor Sub-Assembly**

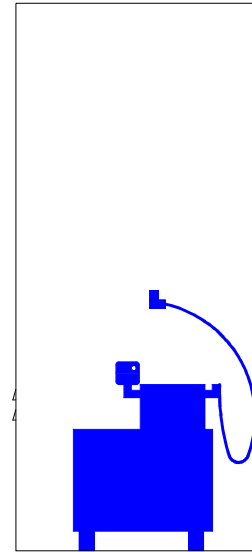

(FIGURE B-3)

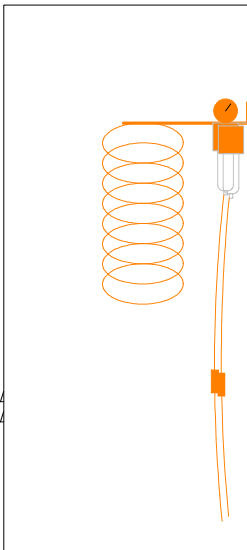

(FIGURE B-4)

**800-550  
N2-GEN™-4 Filter Sub-Assembly**

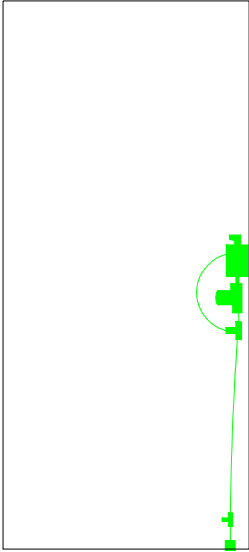

(FIGURE B-5)

**800-510**  
**N2-GEN™-4 Pressure Relief System Sub-Assembly**

**800-560**  
**N2-GEN™-4 Membrane Sub-Assembly**

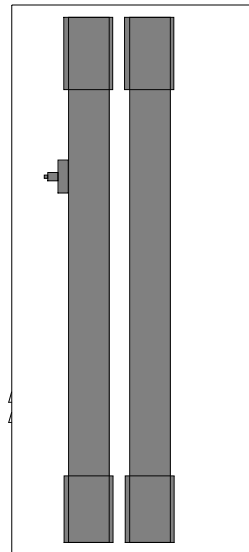

(FIGURE 4-3f)

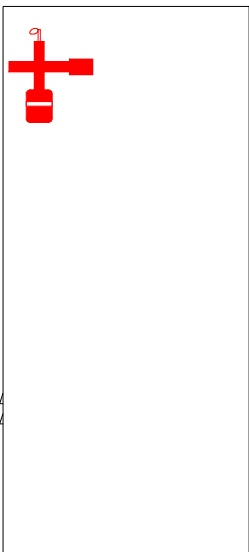

(FIGURE B-7)

**800-520**  
**N2-GEN™-4 Pressure Switch Sub-Assembly**



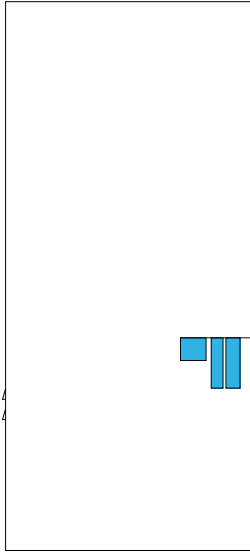







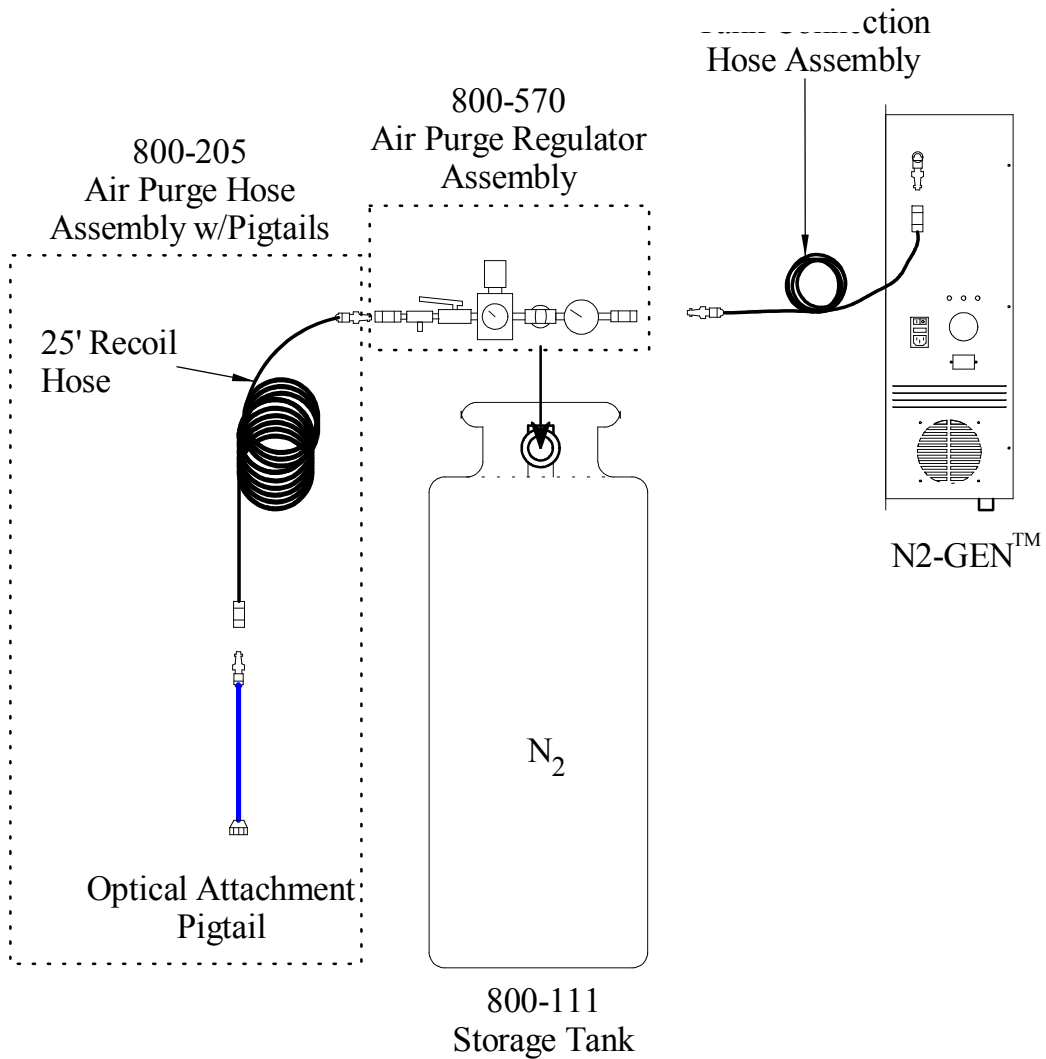



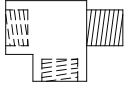

**800-530  
BlastOff™ Sub-Assembly**

(FIGURE B-8)











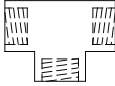

**N2-GEN™-4 System Part  
Identification**



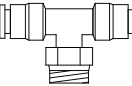

**Individual Spare Parts List** (not to scale)

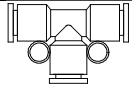
<b>Description</b>	<b>STS Part Number</b>	<b>Located in Subassembly</b>	
1/4" npt Street Tee – Brass	124-380	Filter	
1/4" npt Street Elbow – Brass	124-370	Filter	
		Pressure Switch	
		Compressor	
1/4"npt F x F x Male Tee – Brass	124-340	Filter	
		Pressure Switch	
1/4"npt x 1/4"OD Pushlock Straight	124-458	Filter	
1/4"npt x 1/4"OD Pushlock Elbow – Gray Composite	124-315	Filter	
1/8"npt F x 1/4"OD Pushlock Straight – Gray Composite	124-355	Filter	
1/4"npt Brass Cross	124-330	Pressure Switch	
		Air Purge Regulator	
1/4"npt Hex Nipple	124-325	Pressure Switch	
		Air Purge Regulator	
1/4" Safety Relief Valve 150psi – Brass	800-116	Pressure Switch	
		Air Purge Regulator	
1/4"nptF Bulkhead - Brass	124-305	Pressure Switch	
1/4"npt to 1/4"OD Check-Valve – Gray Composite	124-210	Pressure Switch	
1/4"npt x 5/32"OD Pushlock Straight – nickel plated	124-345	Pressure Switch	
1/8"nptF x 5/32"OD Pushlock Elbow – Gray Composite	124-410	Pressure Switch	

*(TABLE B-2)*







<b>Description</b>	<b>STS Part Number</b>	<b>Located in Subassembly</b>	
1/4"nptF Tee – Brass	124-466	Air Purge Manifold	
1/4"npt to Quick Connect Coupler	800-235	Air Purge Manifold	
1/4"npt Flow Regulator	124-146	Air Purge Manifold	
1/4"npt F Coupler	001-106	Air Purge Manifold	
1/4"npt x 1/4"OD Pushlock Elbow – Compressor Fitting – Nickel Plated	124-460	Compressor	
1/4"npt x 1/4"OD Pushlock Elbow – low profile – Nickel Plated	124-435	Membrane	
1/4"npt x 1/4"OD Pushlock Tee – low profile – Nickel Plated	400-129	Membrane	
1/8"npt Flow Regulator	124-145	Membrane	
1/8"npt x 1/4"OD Pushlock Elbow – gray composite	124-360	Membrane	
1/8"npt x 1/4"OD Pushlock Straight – Nickel Plated	124-458	Membrane	
		Pressure Relief	
1/4"OD Pushlock Tee – Gray Composite	124-320	Pressure Relief	
1/8"npt Hex Nipple	124-405	Pressure Relief	
1/4"OD Check-Valve	124-450	Pressure Relief	

**(TABLE B-2) cont**

Description	STS Part Number	Located in Subassembly	
1/4" Stem to 1/4"OD "Y"	400-155	Pressure Relief	
1/4" OD Panel Bulkhead	124-365	Pressure Relief	

(TABLE B-2)cont

**Hardware Parts List** (not to scale)

Description	Location	
10x32 1/2" Pan Head Screw	Cabinet Cover	
	BlastOff™	
6x32 2" Pan Head Screw	Axial Fan	
6x32 5/8" Pan Head Screw	Axial Fan	
	Power Strip	
	Filters	
6x32 Nylon Locking Nut	Axial Fan	
	Power Strip	
	Filters	
	Membrane Straps	
6x32 1.25" Pan Head Screw	Pressure Relief	
	Membrane Straps	
#6 Washer	Pressure Relief	
1/4"x20 Nylon Locking Nuts	Compressor	

(TABLE B-3)

## Appendix C - Troubleshooting

Symptom	Cause	Remarks
No Power	Power cord is not plugged into socket or the cabinet's receptacle	Make sure that the cord is not cut or frayed.
	The AC outlet is tripped or has an issue	If the outlet trips excessively, consult a professional
The green "Operate" light doesn't come on.	Check the power and fuse.	Unplug and make sure all screws on the terminal strip are tight
	The green light is the operating light, if the compressor stays off, the green light will not illuminate	Wait until the compressor is running and check again.
The amber light doesn't come on.	If the compressor is not running, the amber light should illuminate	Unplug and make sure all screws on the terminal strip are tight
No pressure is showing on the pressure gauge	There is no pressure in the storage tank.	Determine why your tank is empty. Are there leaks?
	System is off and Nitrogen has been used	Power up the system and charge the tank.
	Gauge could be bad.	Connect the Tank Connection hose to the N2-GEN™ and see if there is pressure on the System's Pressure Gauge. They should read the same. Replace the gauge if bad.

*(TABLE C-1)*

**NOTE:**

Always trace all lines and valves to make sure that there are no loose connections or obstructions. Call your POC if you can't determine the cause of the issue. Unplug the N2-GEN™.



# Appendix D – Wiring Diagram

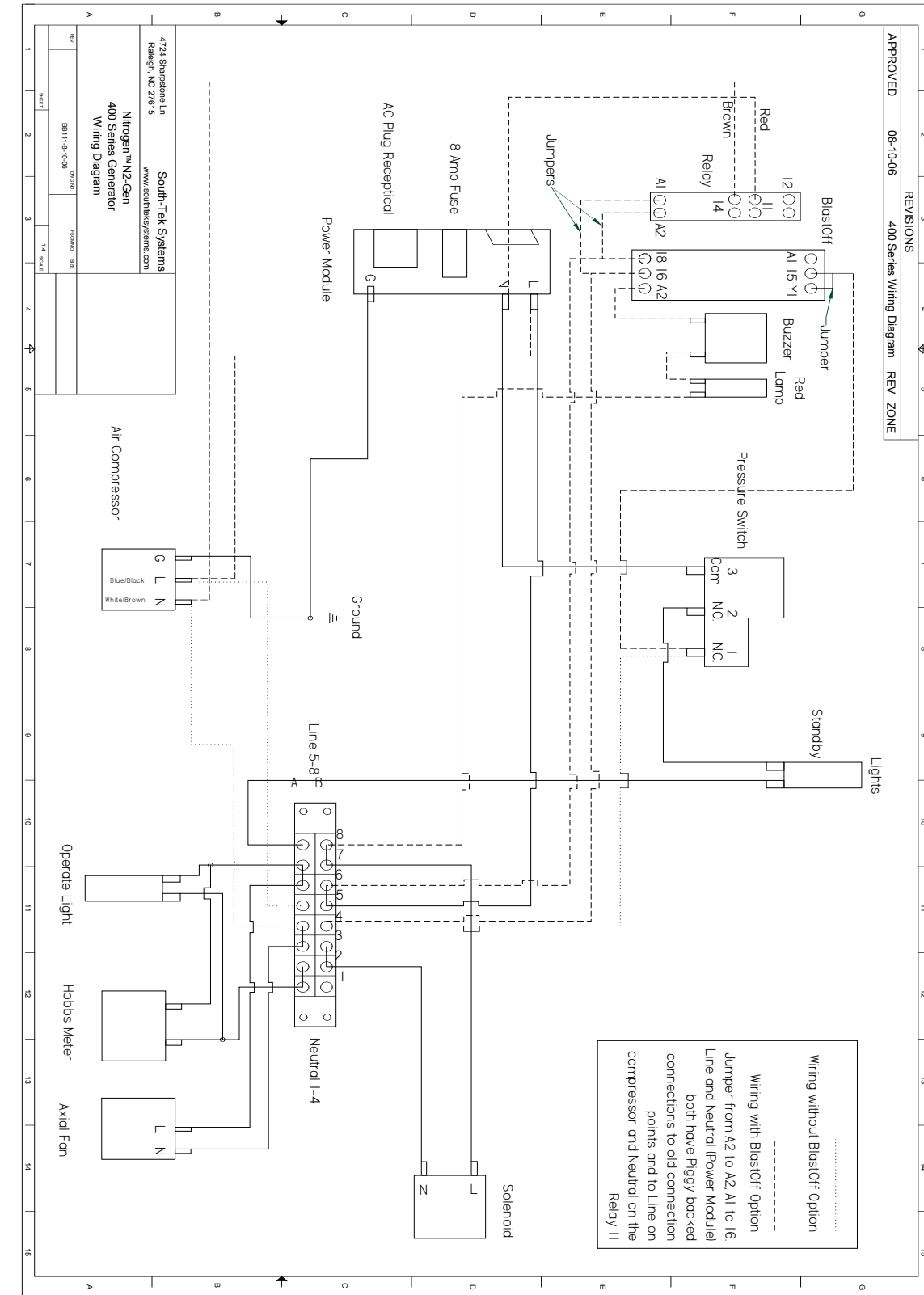

(FIGURE D-1)

## **Appendix E – Warranty - POC**

The N2-GEN™ System is warranted against any defects in workmanship and materials for 12 months from the date of commissioning or 18 months from shipment from South-Tek Systems, whichever comes first. The purchaser has the liability to ensure that the system is fully inspected upon delivery and shall contact the appropriate shipping company to make any claims on damaged goods due to transit within that shipping company's policies. All packages are fully insured through the shipping company during transit. If the packages are damaged in transit, the shipping (freight) company is responsible for all claims. If the system is received with missing parts that are not due to shipping, a written claim should be submitted to South-Tek Systems within 1 week of receiving the shipment. South-Tek Systems can deny all other claims at their discretion.

All warranty work shall be done at a South-Tek System facility. Only factory trained and authorized personnel are covered under warranty repairs. Any part that is returned/repaired/replaced under warranty may be remanufactured or changed to a different specification at the factory's option. Any work performed by an unauthorized person/company or usage of non-factory parts, may void all warranties to the product.

Any item not manufactured by South-Tek may carry its own warranty from its manufacturer and will be warranted by that manufacturer. All parts that need to be returned should be announced. Any item(s) that is returned to South-Tek Systems without an RMA number (return authorization number) may be denied and returned to the sender. Contact the factory for RMA #'s, prior to return shipment. Customer will pay for return shipment to South-Tek Systems' factory in suitable packaging. If packaging is in question, please request factory packaging to be sent to you for sending back the RMA item. South-Tek Systems will pay for return service to the customer (UPS Ground or similar) within the United States.

South-Tek Systems is not liable for damages caused by normal wear and tear, water, fire, erosion, corrosion, explosion, misuse, oil/gas vapors or unauthorized modifications. South-Tek Systems is also not liable for any losses, damages, or cost of delays, including incidental or consequential damages. There are no warranties or guarantees, expressed or implied, including the warranties of merchantability or fitness for a particular purpose or use, other than those warranties expressed herein.



## **Sub-Assembly Replacement Instructions**

### **800-540 Compressor Sub-Assembly**

#### Compressor Removal

1. Always unplug the power cord from the N2-GEN™ before removing the cover.
2. Remove the (6) 10x32 screws that hold the cabinet cover on.
3. Locate the compressor. It will need to be unwired first. Look at the Wiring Diagram in the Appendix. The compressor is wired as following:
  - a. Compressor Brown wire (Neutral) to BlastOff™ Relay #14
  - b. Compressor Blue wire (Line) to Line Power on the Power Switch.
  - c. Compressor Green wire (Ground) to Ground on Terminal Strip.
4. Cut the wire ties that hold all the wires to the tie bases so that the wires may be removed.
5. Unwire the 3 Compressor wires so that the compressor may be removed in the next few steps.
6. The compressor has a Stainless Steel wrapped hose that feeds the supply air to the copper cooling coil. Cut the wire ties that hold that hose in place and disconnect the elbow going to the copper coil.
  - a. The fitting is a “push-on” style fitting. To remove the copper from the fitting, simply press the green collar on the fitting while pulling the copper out. See the photo.
7. Now you only have to remove the four nuts that are holding the compressor to the cabinet. Using a 7/16” socket, remove the 4 nuts from the bottom of the cabinet.
8. Remove the compressor.

#### Compressor Installation

9. Reversing the instructions above, install the compressor’s feet first, make sure to tighten the nuts snug using the supplied nylon locking nuts.
10. Install the supply air hose to the copper cooling coil by just pushing the copper into the fitting. It should insert into the fitting about 1/3 of an inch. Once you bring the system back online, check for leaks at this point since it is the only air fitting involved in this changeout.
11. Pull the wires to the correct locations as stated above in step 3 and rewire the connections using the supplied connectors. Make sure that the connections are good and tight.
12. With the supplied ties, retie neatly all wiring the same way that it was before the compressor was removed.
13. Double-check that you made the correct connections and that all wiring and tubing is connected before repowering the unit.
14. When satisfied that you are connected properly, reconnect your power cord, disconnect your hose that fills your storage tank from the N2-GEN™ output and turn on the power. The reason you disconnect your storage tank is to just check this out with freeflowing N2. The compressor should startup and the pressure gauge on top of the filter assembly should read around 110-120psi. If you see the proper pressure, then you are done. If not, feel around the copper coil fitting and compressor fitting to see if there are any leaks. You can usually use your hand inside the unit to feel any air leaks. Make corrections as necessary or contact your POC for help.

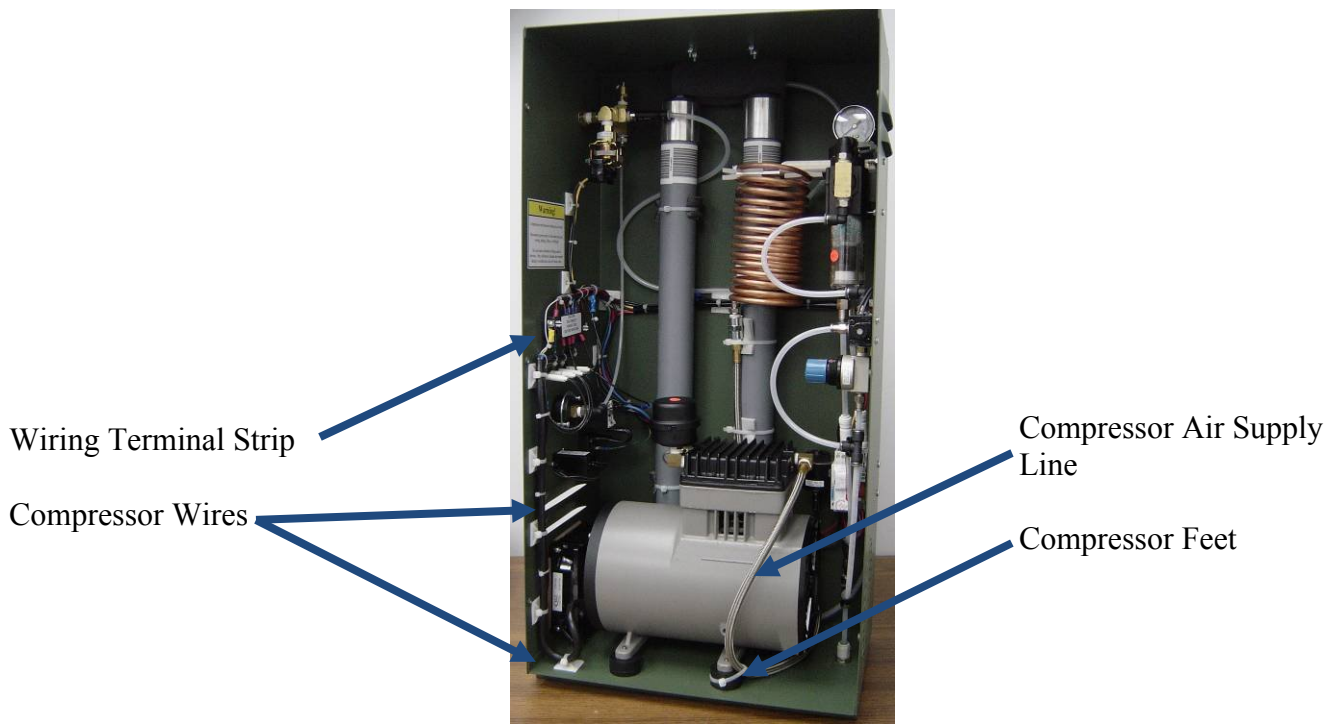

(FIGURE E-1)

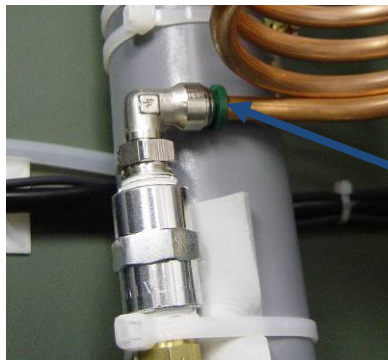

(FIGURE E-2)

Push and hold Green Plastic to release the copper coil.

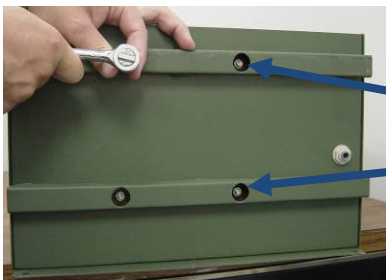

(FIGURE E-3)

On the bottom of the cabinet, use a 7/16 Socket to remove/install the 1/4" nylon locking nuts

## 800-550 Filter Sub-Assembly

### Filter Sub-Assembly Removal

1. Always unplug the power cord from the N2-GEN™ before removing the cover.
2. Remove the (6) 10x32 screws that hold the cabinet cover on.
3. Locate the Filter Sub-Assembly.
4. First, on the Filter Service Indicator that is located on the top of the front filter, you will need to remove the wiring harness. There is a phillips head screw (1) that holds the harness to the indicator body. By unscrewing this screw, the wiring harness can be removed.
5. Second you will need to detach the tubing that is attached to the sub-assembly.
  - a. All the tubing fittings are “push-on” style and can be removed by pushing and holding the plastic ring down while pulling on the tubing.
  - b. Detach the copper coil from the Compressor Supply Line (A)
  - c. Detach the filtered air out tubing (B)
  - d. Detach the tubing labeled (C) in the photo going to the Pressure Relief Sub-Assembly
  - e. Detach the “Y-Stem” from the drain assembly (D)
6. Now unscrew the filter mount from the cabinet. Remove the assembly.

### Filter Sub-Assembly Installation

7. Using the old or newly supplied screws and nuts, install the assembly to the holes in the side of the cabinet. Make sure to use nylon locking nuts so that they won't vibrate loose.
8. Reattach the wiring harness to the Filter Service Indicator. The harness will only fit on one way and the screw needs to be snug, but don't over-tighten.
9. Connect the tubings shown in the photo as (A), (B), (C), and (D)
10. Repower the system and check for leaks by hand. The pressure gauge on top of the filter assembly should show 110-120psi. If pressure is lower, you have a leak, make corrections. If you can't correct, contact POC.

Screw to remove the Wiring Harness from the Filter Service Indicator



(FIGURE E-4)



(FIGURE E-5)

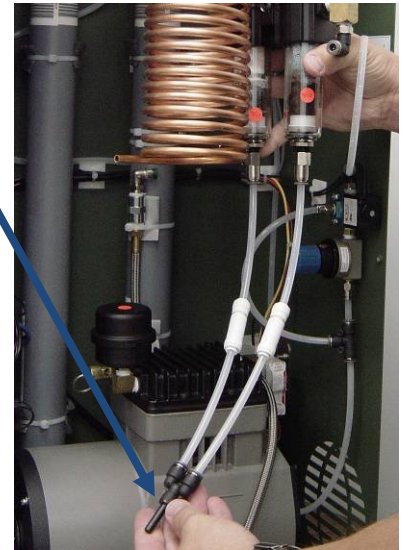

(FIGURE E-6)

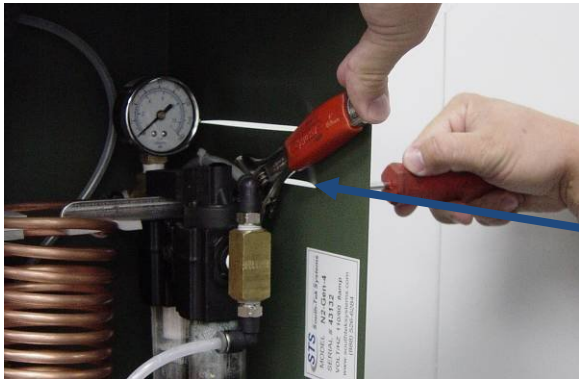

(FIGURE E-7)

Use a wrench and a screwdriver to remove the screws (2) holding the assembly to the cabinet

## 800-510 Pressure Relief System Sub-Assembly

### Pressure Relief System Sub-Assembly Removal

1. Always unplug the power cord from the N2-GEN™ before removing the cover.
2. Remove the (6) 10x32 screws that hold the cabinet cover on.
3. Locate the Pressure Relief System Sub-Assembly.
4. Detach the Tubing from the top of the Solenoid to the Filter Assembly (A).
  - a. All the tubing fittings are “push-on” style and can be removed by pushing and holding the plastic ring down while pulling on the tubing.
5. Detach the tubing from the lower half of the Pressure Relief System (B).
6. Cut the wiring coming from the Solenoid leaving about 4-6” of wire coming from the solenoid.
7. Unscrew the 2 screws holding the assembly to the cabinet and remove the assembly.

### Pressure Relief System Sub-Assembly Reinstallation

8. Using the old or newly supplied screws and nylon locking nuts, attach the assembly to the 2 holes in the side of the cabinet where the old assembly was removed from.
9. With an electrical crimper, strip and reconnect the old wires to the new connectors using a butt connector. There is no positive/negative, just connect them tight.
10. Reattach the tubing (A) and (B).
11. Repower the system and check for leaks by hand. The pressure gauge on top of the filter assembly should show 110-120psi. If pressure is lower, you have a leak, make corrections. If you can't correct, contact POC.



(FIGURE E-8)

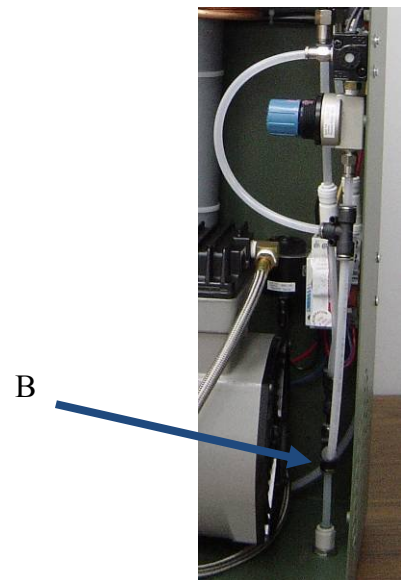

(FIGURE E-9)

## **800-560 Membrane Sub-Assembly**

### Membrane Sub-Assembly Removal

1. Always unplug the power cord from the N2-GENT™ before removing the cover.
2. Remove the (6) 10x32 screws that hold the cabinet cover on.
3. Locate the Membrane Sub-Assembly. They are the 2 long grey tubes at the back of the cabinet.
4. You will need to detach the tubing inlet and outlet to the assembly. The outlet is pushed into the Pressure Switch Assembly (A).
  - a. All the tubing fittings are “push-on” style and can be removed by pushing and holding the plastic ring down while pulling on the tubing.
5. Now detach the membrane input tubing (B) from the filter assembly.
6. Cut the cable ties that are on the shafts of the membranes. Note that the copper coil fitting is cable tied to the right membrane for strength. You will put the ties back on the same way.
7. Now that all the ties are cut, you can remove the membranes.

### Membrane Sub-Assembly Reinstallation

8. There are 4 cable tie bases on the back of the cabinet that will hold the membranes in place. Install 4 long cable ties in the horizontal plane so that the new membrane assembly can be installed and held in place.
9. Install the new Membrane Sub-Assembly by lining up the membranes in front of the cable tie bases. There is a label with a serial number on each membrane; they should be at the top of the cabinet.
10. Make sure there are 4 round foam inserts that line up around the membranes at the cable ties so that when you tighten the cable ties down, they will be gripping around the foam.
11. Once the membranes are tied in, retie the copper coil fitting to the right membrane with 2 ties so that it is supported.
12. Route the tubing coming from the top of the membrane assembly including the membrane tuning valve (not to be adjusted except for by the factory) as shown in the photo and attach the tubing to the Pressure Switch Assembly (A).
13. Attach the tube from the bottom of the Membrane Assembly to the Filter Assembly (B).
14. Repower the system and check for leaks by hand. The pressure gauge on top of the filter assembly should show 110-120psi. If pressure is lower, you have a leak, make corrections. If you can't correct, contact POC.

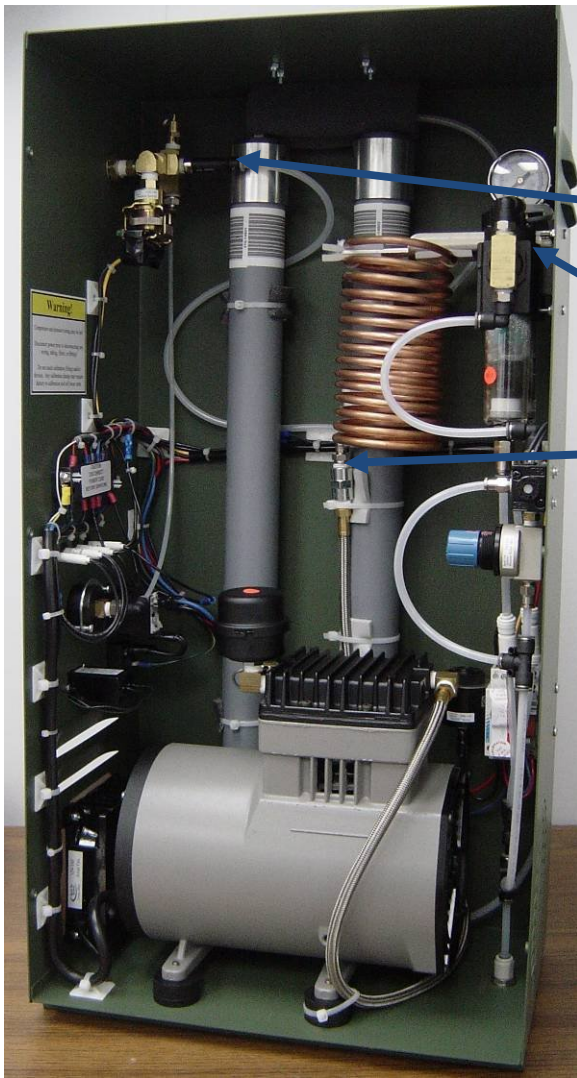

(FIGURE E-10)

A - Pressure Switch Assembly

B - Filter Assembly Connection

Copper Coil Fitting



A - Pressure Switch Assembly

Membrane Tuning Valve

(FIGURE E-11)

## **800-520 Pressure Switch Sub-Assembly**

### Pressure Switch Sub-Assembly Removal

1. Always unplug the power cord from the N2-GEN™ before removing the cover.
2. Remove the (6) 10x32 screws that hold the cabinet cover on.
3. Locate the Pressure Switch Sub-Assembly. Upper left corner of the cabinet.
4. You will need to detach the tubing on the inlet that comes from the Membrane Sub Assembly.
  - a. All the tubing fittings are “push-on” style and can be removed by pushing and holding the plastic ring down while pulling on the tubing.
5. Detach the small 5/32” tubing that is connected to the pressure gauge.
6. Now remove the electrical tape from the pressure switch.
7. Loosen the 3 screws only enough to remove the spade connectors that are installed. Make note of which wire goes to which terminal for reinstall. Use tape with numbers or similar so that you don’t cross the wires up on reinstall.
8. Remove the exterior connections from the output bulkhead.
9. Remove the bulkhead nut holding the Pressure Switch Assembly to the cabinet and remove the assembly.

### Pressure Switch Sub-Assembly Reinstallation

10. Insert the new Pressure Switch Sub-Assembly through the 3/4” hole and fasten the washer and nut on the outside of the cabinet. Make sure the assembly is level before tightening the nut firmly.
11. Install the wires onto the correct poles of the pressure switch and tighten well. Re-tape the pressure switch so that all electrical wire connectors are covered and insulated.
12. Reinstall the tubing going to the pressure gauge and pressure switch.
13. Repower the system and check for leaks by hand. The pressure gauge on top of the filter assembly should show 110-120psi. If pressure is lower, you have a leak, make corrections. If you can’t correct, contact POC.





Pressure Switch Inlet

Pressure Gauge Connection

(FIGURE E-12)

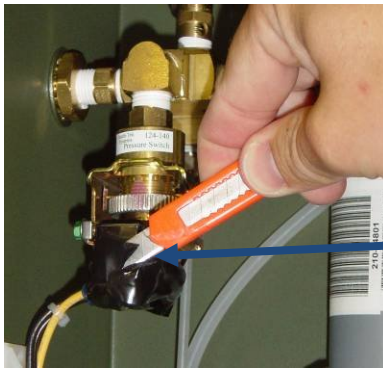

Cut the Electrical Tape

(FIGURE E-13)



Electrical Connections

(FIGURE E-14)

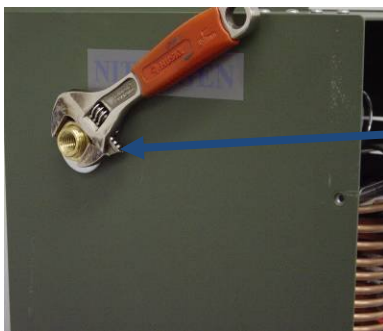

Bulkhead Washer and nut

(FIGURE E-15)

## **800-530 BlastOff™ Sub-Assembly**

### **BlastOff™ Removal**

1. Always unplug the power cord from the N2-GEN™ before removing the cover.
2. Remove the (6) 10x32 screws that hold the cabinet cover on.
3. Locate the BlastOff™. It will need to be unwired first. Look at the Wiring Diagram in the Appendix for any questions.
4. Using a small Phillips screwdriver, loosen the wire lugs on the controller and relay. They are color coded. Don't loosen the wires that are jumpers from one terminal to the other within the BlastOff™ Assembly.
5. Cut the shrink tubing on the brown wire coming from the bottom of the buzzer. Unscrew the ring terminal so that you can reinstall the wire on the new BlastOff™.
6. On the outside of the cabinet, unscrew the 2 screws holding the BlastOff™ to the cabinet and remove the assembly.

### **BlastOff™ Installation**

7. Reversing the instructions above, install the new BlastOff™ with the old or newly supplied screws to the cabinet.
8. Reinstall the wiring as follows:
  - a. Yellow wire (top) to Controller #15
  - b. Red wire (top) to Relay #11
  - c. Brown wire (top) to Relay #14
  - d. Red wire (bottom) to Controller #16
  - e. Blue wire (bottom) to Controller #A2
  - f. Brown wire (bottom) to Buzzer open connector, wrap connection with electrical tape after tightened.
9. Double-check that you made the correct connections and that all wiring and tubing is connected before repowering the unit.
10. When satisfied that you are connected properly, reconnect your power cord, disconnect your hose that fills your storage tank from the N2-GEN™ output and turn on the power. The reason you disconnect your storage tank is to just check this out with free flowing N2. The compressor should startup and the pressure gauge on top of the filter assembly should read around 110-120psi. If you see the proper pressure, then you are done. If not, feel around the copper coil fitting and compressor fitting to see if there are any leaks. You can usually use your hand inside the unit to feel any air leaks. Make corrections as necessary or contact your POC for help.

BlastOff™ Controller

BlastOff™ Relay

Mounting Screws

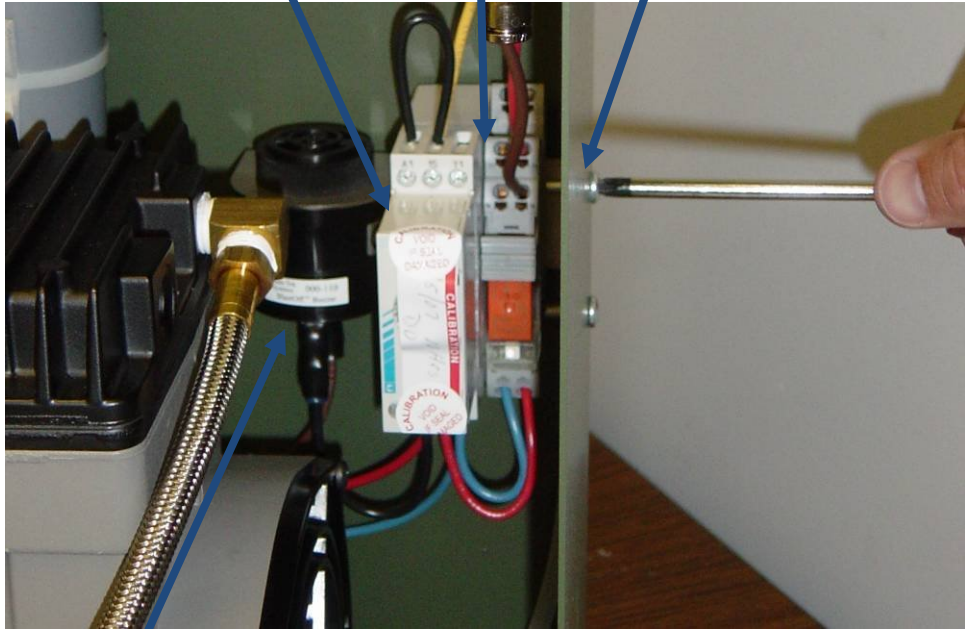

(FIGURE E-16)

Buzzer