



**N<sub>2</sub>-BLAST®**  
**FPS-650 & FPS-1250**  
**O&M MANUAL**

Revision 7  
Date 09/06/19



## VERSION HISTORY

Revision #	Implemented By	Revision Date	Approved By	Approval Date	Reason
1	J. Nguyen	10/13/15	A. Norman	10/13/15	Initial Release
2	J. Nguyen	7/5/15	A. Norman	7/5/15	
3	J. Nguyen	8/15/16	A. Norman	8/15/16	
4	J. Nguyen	4/27/16	A. Norman	4/27/16	Updated Bypass Info
5	Matt Thomas	9/20/16	A. Norman	9/30/16	Updated EU rating info
6	Kyle Mellott	8/10/17	J. Nguyen	8/14/17	MiniPSAv7 Release
7	Kyle Mellott	8/9/19	M. Thomas	9/6/19	MiniPSAv9 Release

-----Notes-----

# TABLE OF CONTENTS

- 1 INTRODUCTION ..... 4**
  - 1.1 Purpose ..... 4
  - 1.2 Audience ..... 4
  - 1.3 Important Information ..... 4
- 2 SAFETY GUIDELINES ..... 5**
  - 2.1 General ..... 5
- 3 SYSTEM DESCRIPTION ..... 7**
  - 3.1 Key Features ..... 7
  - 3.2 Specifications ..... 8
  - 3.3 System Operations ..... 9
- 4 PRODUCT INSTALLATION ..... 10**
  - 4.1 Unpacking and Preparation ..... 10
  - 4.2 Electrical Requirements ..... 11
  - 4.3 Installation (For FPS-650) ..... 11
  - 4.4 Installation (For FPS-1250) ..... 13
  - 4.5 Panel Layout and Gas Connections ..... 14
  - 4.6 Air Bypass Setup (optional) ..... 17
  - 4.7 Start-up Procedures ..... 17
  - 4.8 Checking for Leaks ..... 18
  - 4.9 Access Controls ..... 19
  - 4.10 Starting the System ..... 19
  - 4.11 Stopping the System ..... 19
- 5 SYSTEM USAGE ..... 20**
  - 5.1 Instructions ..... 20
  - 5.2 Alarm Notification ..... 20
- 6 SYSTEM MAINTENANCE ..... 21**
- 7 KEY CONTACTS ..... 24**
- 8 FAQs ..... 24**
  - 8.1 Power Issues ..... 24
  - 8.2 Pressure Issues ..... 24
  - 8.3 Gas Leaks ..... 24
  - 8.4 BlastOff™ - Leak Detection System: ..... 25
- APPENDIX A: WARRANTY ..... 26**
- APPENDIX B: INTERNAL QUICK FILL COMPRESSOR OPTION FOR FPS-1250 ..... 27**

# 1 INTRODUCTION

## 1.1 PURPOSE

The *N<sub>2</sub>-BLAST®* FPS-650 and FPS-1250, provide an economical, precise means of generating high purity Nitrogen. Since air is comprised of ~79% N<sub>2</sub>, the N<sub>2</sub> Generator is a simple and cost-effective way to separate the N<sub>2</sub> from the air. Nitrogen is an inert gas (non-combustible) and widely used in thousands of industries along with Fire Protection Systems. The N<sub>2</sub> is “generated” by means of the air compressor pushing air into the simple, safe filtering vessels, which in turn mechanically separates N<sub>2</sub> molecules from other molecules found within air.

**\*\*The installer and the user should read this manual in its entirety.**

## 1.2 AUDIENCE

This manual is intended for Installer/Supervisory Staff and should be read in its entirety prior to operation.

Please contact your local distributor provider for any operation and maintenance first prior to contacting the manufacturer.

## 1.3 IMPORTANT INFORMATION

All personnel (and their supervisors) installing, operating, and maintaining the *N<sub>2</sub>-BLAST®* must read and fully understand this manual prior to installing, operating or performing maintenance on the system.

The *N<sub>2</sub>-BLAST®* produces Nitrogen (N<sub>2</sub>) at a low flow rate, which quickly dissipates into the air. N<sub>2</sub> gas is not poisonous but the gas should not be directly inhaled since in high concentrations it can cause asphyxiation. Ensure the unit is installed within a well-ventilated room, one that is not sealed off from normal living space air changes.

All personnel involved with installation, operations, and maintenance of the *N<sub>2</sub>-BLAST®* must follow safe working practices, OSHA, and local health/safety code regulations during the installation, operation, and maintenance of the unit.

## 2 SAFETY GUIDELINES

### 2.1 GENERAL

Correct use of the FPS-650 and FPS-1250 is important for your personal safety and for trouble-free functioning of the FPS-650 and FPS-1250. Incorrect use can cause damage to the FPS-650 and FPS-1250 or can lead to incorrect gas supply.

The FPS-650 and FPS-1250 produces Nitrogen (N<sub>2</sub>) at a low flow rate, which quickly dissipates into the air. N<sub>2</sub> gas is not poisonous but it should not be directly inhaled, since in high concentrations, they can cause asphyxiation. **Ensure that the unit is installed within a well-ventilated room, one that is not sealed off from normal living space air changes.**

Read carefully and act accordingly before installing, operating, or repairing the unit.

- Operator must use safe working practices and rules when operating the nitrogen generator.
- The owner is responsible for keeping the unit in safe operating condition at all times.
- Always use approved parts when performing maintenance and repairs. Make sure that replacement parts meet or exceed the original parts' specification.
- Only authorized, trained, and competent individuals can perform installation, operation, maintenance, and repair.
- Completely isolate incoming and outgoing pressures to the generator, and make sure to depressurize the service/repair section prior to performing any mechanical work, including changing the filters. The nitrogen generator's exhaust gas and/or any venting gas must be vented to the outside or to a large, well-ventilated room to avoid suffocation due to lack of oxygen.
- Safety glasses should be worn if the cabinet door is open while the machine is operating.
- Use ear protection when the equipment is operating.

**WARNING:** Pressurized gases are contained within the generator, the receiver, and product tanks. Pressurized gases are dangerous and may cause injury or death if handled or used inappropriately.

- Never allow pressurized gas to exhaust from an unsecured hose. An unsecured hose may exhibit a whipping action, which can cause serious injury. If a hose should burst during use, immediately close all isolation valves if it is safe to do so and power down the unit.

- Never disable or bypass any safety relief valves.
- Always make certain that the nitrogen generator is disconnected from the supply power prior to performing any electrical work.

NOTE: Always following local and site safety regulations in conjunction with this manual.

Correct use of the nitrogen generator is important for your personal safety. Incorrect safety practices can cause damage to yourself and/or to the equipment.

All personnel involved with installation, operations, and maintenance of the FPS-650 and FPS-1250 must follow safe working practices, OSHA, and local health/safety code regulations during the installation, operation, and maintenance of the unit.

**Warning:**

- **This manual must be read in its entirety to installing and operating the FPS-650 and FPS-1250 to prevent accidents and damage to the FPS-650 and FPS-1250.**
- **Contact your supplier if you detect a problem that you cannot solve with this manual.**
- **Only use the FPS-650 and FPS-1250 in accordance with its designed purpose.**
- **Only service-engineers, that are qualified to work on electric and pneumatic equipment, can do the installation, maintenance and repairs. Unqualified people are not allowed to repair the equipment.**
- **Do not tamper or experiment with the equipment or exceed the technical specifications**

### 3 SYSTEM DESCRIPTION

#### 3.1 KEY FEATURES

The FPS-650 and FPS-1250 key features include the following:

- Air compressor
- Air Filters
- Programmable Logic Controller (PLC)
- Pressure Swing Adsorption Beds
- Safety Relief Valves
- N2 Storage Tank
- Automatic Pressure Cut-in/Cut-out
- STS Patented Blast-Off (optional)

##### Air Compressor:

The air compressor is designed internally to the cabinet and features engineered dampening system to reduce vibration and noise throughout the cabinet. It is an oil-less compressor with a pre-filter attached to the air input. The recommended replacement on the pre-filter is 1000 run hours or 1 year (whichever comes first). Dirtier environments may be required to be changed out more frequently. Consult your supplier for a different filter maintenance schedule if you are installing the generator in dirty environment.

##### Air Filters:

The generator has two filters after the air compressor: the particulate and coalescing. The Particulate has a 5-micron filter that will catch any of the larger particles. The Coalescing has a 0.1-micron filter that will catch the remaining smaller particles. Both filters feature and auto-drain that will drain the water captured after the air compressor. The drain is plumbed to the outside of the cabinet where the end-user can then connect ¼" tubing and drain to a safe location.

##### Programmable Logic Controller (PLC):

There's an integrated PLC within the cabinet. It features smart and efficient coding to maximize the performance of the generator. It controls the timing and sequencing of the valves to effectively move compressed gas throughout the system. It also has a smart feature to automatically go into different "modes" based on the current run stages. It comes with a visual screen that will display run hours and alarms.

Safety Relief Valves:

Safety Relief Valves have been placed throughout the system for maximum safety. They are designed and put in place to minimize failure of other components. They all come with an ASME stamp.

N2 Storage Tank:

A N2 Storage Tank is housed inside the cabinet with manual ball valves and gauge. It is plumbed to an external manual ball valve so that the end-user will not have to do any plumbing within the cabinet.

Automatic Cut-In/Out:

The generator comes with a built-in pressure switch that is tied into the PLC. This will provide a low voltage signal back to the PLC to put the system in a “Standby Mode” when the tank is full of Nitrogen.

Patented Blast-Off Detection (optional):

The Blast-Off Leak Detection will provide the end-user with an alarm when it detects characteristics of a leak somewhere on the system. It will trigger an audible alarm, display it on the screen, and the end-user can tie into the dry contact so that the alarm can be relayed back to the Building Management System (BMS).

**3.2 SPECIFICATIONS**

**Table 1: Specification Data**

N2-Blast® FPS-650 and FPS-1250 – Specifications	
Nitrogen Purity	98.0+%
Installation	Wall Mount (FPS-650) / Floor standing (FPS-1250)
Display	Run Hours / Run Status / Alarm Status
N <sub>2</sub> Storage Pressure	55-75 PSIG
Cabinet Port Connections	1/2" NPT Female
Electrical	110-240V / 50-60Hz / 1Phase; 20 Amp Breaker
Compressor	Integral / Oil-Free
Ambient Temperature	40° to 90°F
Noise Level (dbA)	< 75 dbA (Nitrogen Generator)
Size	12.68" W x 10" D x 29.5" H (FPS-650 Cabinet Dimensions) 26" W x 18" D x 59" H (FPS-1250 Cabinet Dimensions) 15.1" OD x 50" H (100# Tank for FPS-650 Only)
Weight	Appx: 84 lbs (FPS-650) Appx: 265 lbs (FPS-1250) Appx: 75 lbs (100# Tank)

### 3.3 SYSTEM OPERATIONS

The system has two standard run modes – Run and Standby. When the power switch is turned on, the controller will automatically determine which mode to enter and will display the current run mode on the screen – “Run” in Green and “StdbY” in Yellow. The layout of the controller can be seen on the next page.

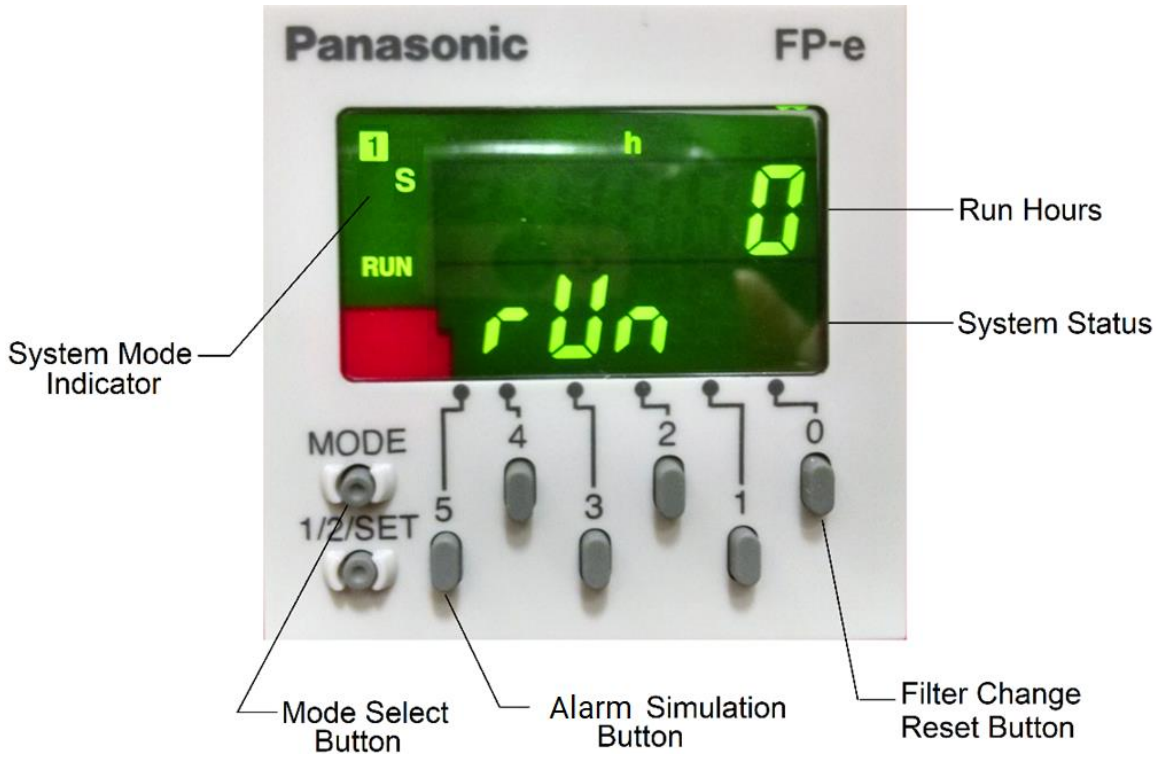

Figure 1: Controller Display

#### System Status

“Run” mode is when the FPS-650 and FPS-1250 is producing nitrogen and feed it to the storage tank. The system will automatically enter “Standby” mode when the tank is fully pressurized (65-75 psig). It will remain in “Standby” mode until the tank pressure falls 7-10 psig.

### Lock and Unlock Controller

To utilize the buttons on the front of the controller the unit must be unlocked. If the system is displaying “**LOCK**” the Mode Select Button may be pressed and held to unlock the controller (Repeat this step if a system lockout is desired). Unlocking the controller allows access to two features:

- Alarm Simulation (5) – Hold the Alarm Simulation Button for 3 seconds to activate. This will simulate an alarm condition and trip the alarm dry contact in the unit (if installed) for 2 seconds so that proper functioning can be confirmed.
- Filter Change Reset (0) – When a new FRP (Filter Replacement Kit) is installed, the 1000-hour filter change time must be reset. After replacing the filter elements, press and hold the Filter Change Reset Button for 7 seconds. An audible beep will confirm that the filter change time and filter alarm are reset.

## **4 PRODUCT INSTALLATION**

### **4.1 UNPACKING AND PREPARATION**

The *N<sub>2</sub>-BLAST®* FPS-650 System’s cardboard carton should be carefully opened and all parts should be inspected for damage upon receipt. For the *N<sub>2</sub>-BLAST®* FPS-1250 system, a wooden crate is used for shipping and should be opened on the side noted on that crate. Identify and verify that all parts listed on the packing list are present and undamaged. South-Tek Systems (STS) is not responsible for damages that have occurred during the shipping and handling of the *N<sub>2</sub>-BLAST®*. Any visual damages should be immediately documented and reported to the shipping company responsible. Then, contact STS at (888)526-6284 to assess the damages only after the shipping company has been notified.

#### **Until Installation:**

- Store the *N<sub>2</sub>-BLAST®* in a dry and climate controlled (60-80°F recommended) room.
- Always keep *N<sub>2</sub>-BLAST®* in an upright position / or in box as shipped.
- Do not connect the AC power cable until this manual has been read completely and all connections are made as stated within.
- Keep all gas lines dry so moisture does not enter generator upon hookup.
- Never place/stack objects on top of the *N<sub>2</sub>-BLAST®*.

To remove FPS-1250 from crate, unbolt cabinet from the crate. Carefully, lift unit from the crate and set it on the floor. Use a floor jack to move it to the final location. Once in place, unbolt the 4 colored bolts at the bottom of the cabinet.

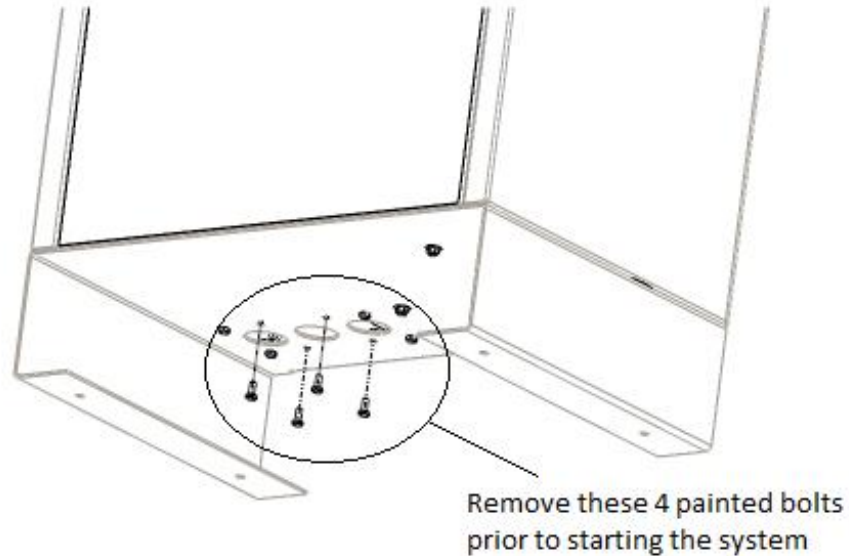

**Figure 2: Shipping Lock Bolts**

Carefully, break down the crate and store in a safe location in the case that it may need to be sent back to the factory for service.

## 4.2 ELECTRICAL REQUIREMENTS

The FPS-650 and FPS-1250 requires 110–125VAC / 50-60hz / 1ph / 20A or 220-240VAC / 50-60hz / 1ph / 20A connection. A dedicated circuit is suggested for each install. The electrical panel as a 20A circuit breaker built into the on/off rocker switch. The system is UL 508A ICP approved. Electrical schematic available upon request.

## 4.3 INSTALLATION (FOR FPS-650)

The N<sub>2</sub>-BLAST® FPS-650 can be mounted to a wall or placed on a floor. It is recommended that the N<sub>2</sub>-BLAST® FPS-650 be mounted to a weight-bearing wall that can support its weight as specified in 3.2 Specifications. If placed on the floor, it should still be fastened in place so that it cannot move due to vibration or damaged from falling over. The N<sub>2</sub>-BLAST® should always be installed indoors in an environment between 40° and 90° F in the upright position where it will not be damaged by water or moving equipment. Leave at least 6" on the left side of the cabinet for ventilation, but 36" is recommended for access to the control panel, tube/pipe connections, and the front cover. There is a ¼" OD tube drain port on the bottom right of the cabinet. This can be plumbed to the nearest site drain.

There is an optional mounting bracket kit (STS Part #: A05-TYP1-RD), that allows you to mount the system on a standard 16" wall stud width. Otherwise, use the mounting holes on the cabinet for mounting the N<sub>2</sub>-BLAST® securely and level, directly to the wall.

### Optional Mounting Bracket Kit Procedures

1. All N<sub>2</sub>-BLAST<sup>®</sup> mounting holes and optional mounting bracket holes are for ¼" screws/anchors.
2. All brackets must be installed in orientation as shown to work correctly.
3. Install the cabinet-mounting brackets on the N<sub>2</sub>-BLAST<sup>®</sup> first with the bolts/lock nuts that are provided.
4. Locate the wall-mounting bracket. It is an 18" bracket without the rectangular cutouts and will need to be installed on the wall at the desired height and level. The bracket has 16" center to center holes so the unit can be mounted directly to studs. This bracket will need to be mounted per the diagram below using appropriate for your type of wall material (wood, sheet metal, masonry, etc....). Once the 18" bracket has been wall-mounted, this will allow the 12" bracket that is fastened to the top flange of the cabinet a fixed anchor to hang from. See diagram as to how the angles are to be oriented on the back of the cabinet vs the wall.
  - a. Use the supplied nuts and bolts to attach the upper 12" bracket onto the top flange per the diagram.
  - b. Use the supplied carriage bolts and nuts to attach the 18" lower bracket to the bottom flange, don't overtighten the nuts yet. After installing the system, you may want to offset the bracket slightly, hence the rectangular slots.
5. Optional: if wall studs are not 16" center-to-center or you have the need to reinforce the mounting area, a ½" or thicker board of plywood is recommended to be installed prior to hanging the system. Use best general practices to ensure that the wood and system will be secure at its full weight and remember that it will be vibrating from compressor running.
6. Once the mounting brackets are all in place, hang the N2 Blast cabinet from the top bracket making sure it is centered.
  - a. The cabinet should have at least 4" on either side for breathing/cooling purposes.
  - b. Do not install near heat source or where steam or water is present. Damage to system or bodily harm may result as well as voiding warranty.

**Warning: Secure the N<sub>2</sub>-BLAST<sup>®</sup> to the wall at the top and bottom flanges. Failure to do so could cause damage or bodily injury.**

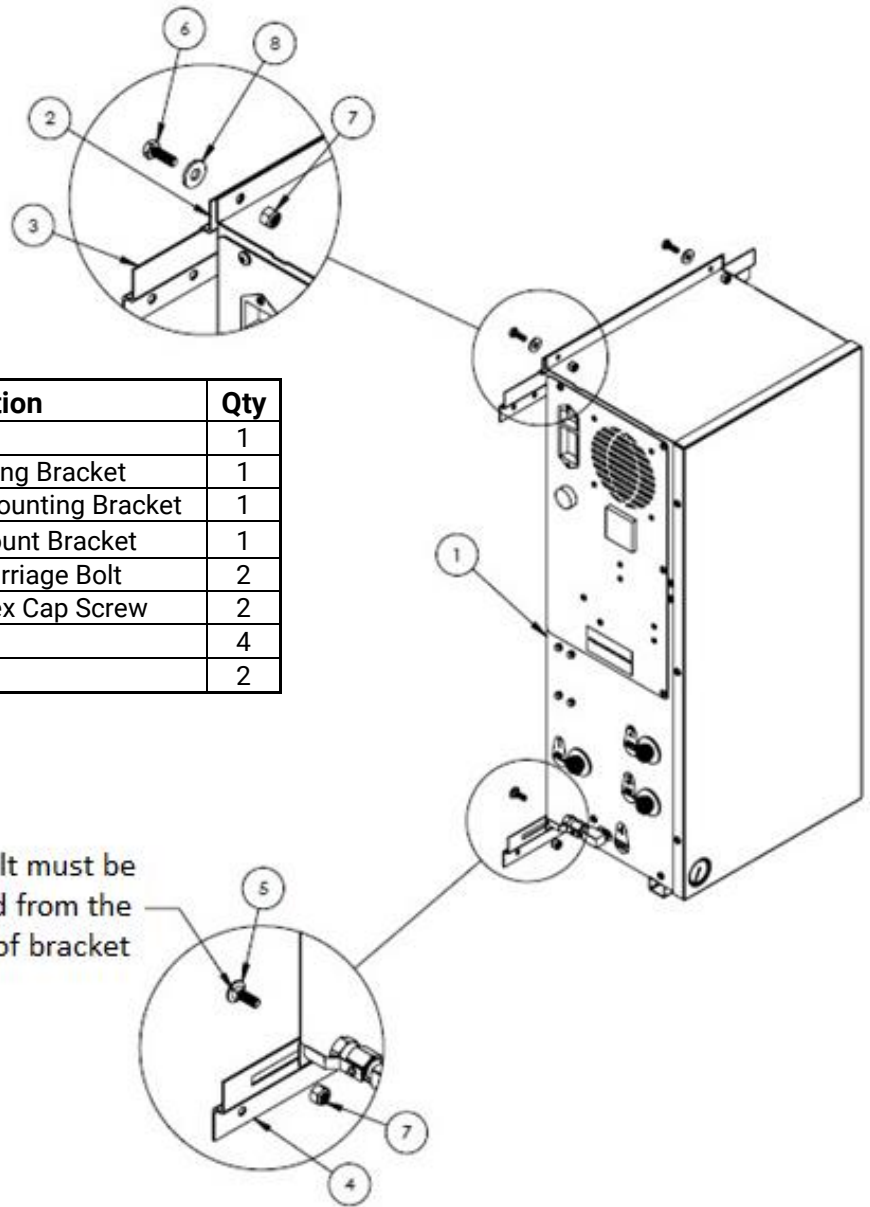

Item #	STS Part #	Description	Qty
1	FPS-650	Mini PSA	1
2	800-133	S-100/200 12" Mounting Bracket	1
3	800-134-B	S-100/200/400 18" Mounting Bracket	1
4	800-129	Type 1 Lower Wall Mount Bracket	1
5	Misc	0.250" -20 x 0.750" Carriage Bolt	2
6	Misc	0.250" -20 x 0.750" Hex Cap Screw	2
7	Misc	0.250" Nylock Nut	4
8	Misc	0.250" Flat Washer	2

Figure 3: FPS-650 Wall Mounting Diagram

**4.4 INSTALLATION (FOR FPS-1250)**

The N<sub>2</sub>-BLAST® FPS-1250 must be installed on a flat level hard surface as there are no wall mount options available. Anchoring to the floor is not required (unless by local code). Make sure there is clearance room on the top for N<sub>2</sub> gas connection, clearance room on the left side for access to the panel, and clearance room on the front for maintenance access.

See Figure 6 for dimensions and overall connections to the system.

### 4.5 PANEL LAYOUT AND GAS CONNECTIONS

See figures below for panel layout and gas connections. Double-check all connection locations before turning on the system or opening any valves. Note: All *N<sub>2</sub>-BLAST®* models are factory equipped with 1/2" NPT Female connections. For FPS-650 Layout See Figure 4. For FPS-1250-Layout See Figure 6.

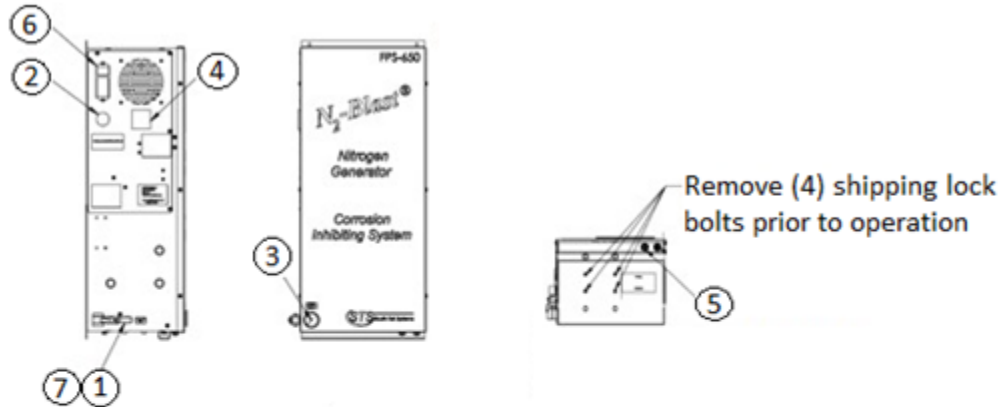

External Components		
Item #	Description	Service
1	1/4" NPT Ball Valve	N2 Out
2	Audible Electric Buzzer	Audible Alarm
3	1/8" NPT x 1-1/2" 100 PSIG Gauge	N2-Storage Pressure
4	PLC	System Controller
5	1/4" OD Through-Wall Coupling	1/4" OD Drain
6	Power Entry Module, 20 Amp	System Main Power Connection
7	1/4" NPT M x 1/2" NPT F Adapter	N2-Out Adapter for 1/2" Plumbing

Figure 4: FPS-650 Panel Layout

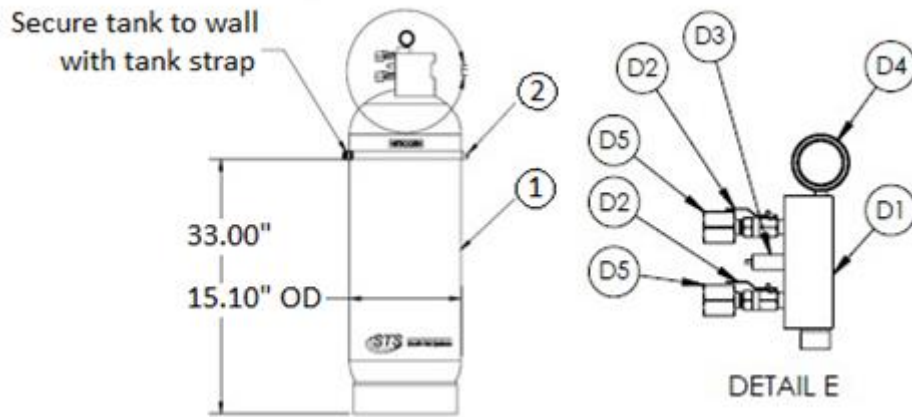

Item #	STS Part #	Description	Qty
1	800-111-FPS	100 # Red Tank w/ Label	1
2	A01-0100-A	100# Tank Strap Assembly	2
3	A01-0100-S-A	Tank Manifold w/ 0.500" NPT Fittings	1

Item #	STS Part #	Description	Qty
D1	800-245-A	Tank Manifold	1
D2	124-308	0.250" NPT M x F Ball Valve, Brass	2
D3	124-335-A	0.250" Safety Relief, 115 PSIG	1
D4	124-125	0.250" NPT x 02.000" 1-160 PSIG Gauge	1
D5	524-218	0.500" NPT F x 0.250" NPT M Reducer, Brs	2

Figure 5: 100# N2 Storage Tank Setup

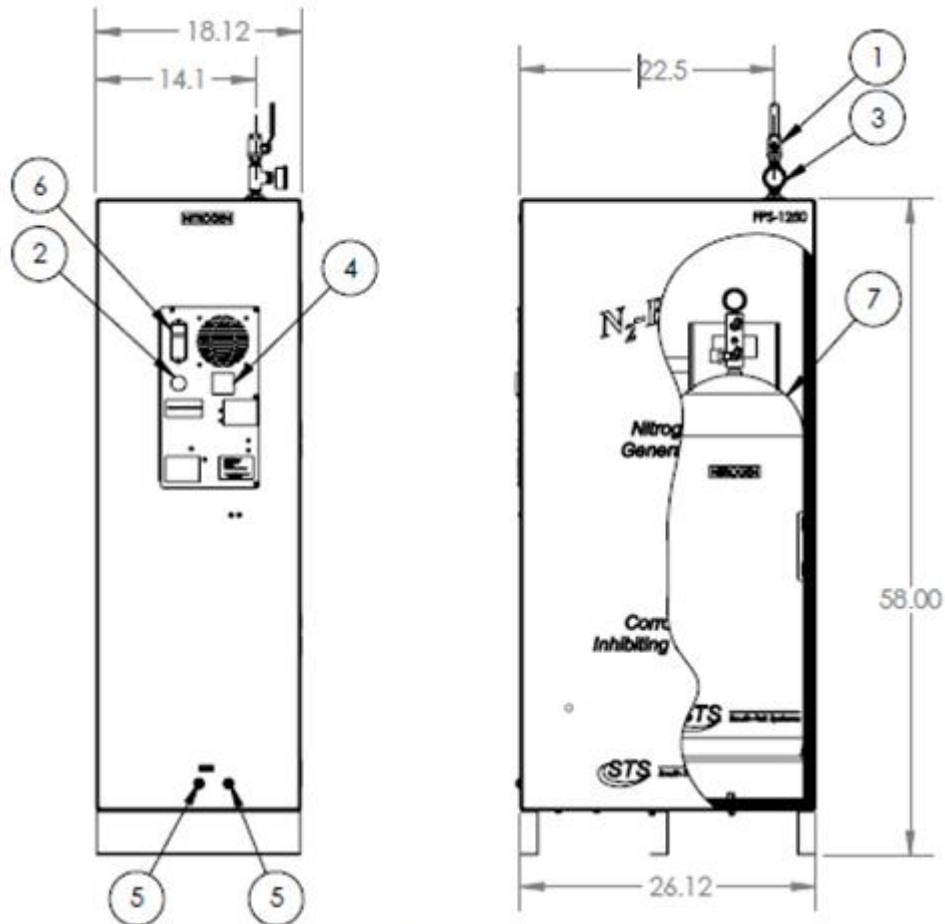

External Components		
Item #	Description	Service
1	1/4" NPT Ball Valve	N2 Out
2	Audible Electric Buzzer	Audible Alarm
3	160psi Pressure Gauge	N2-Storage Tank Pressure
4	PLC	System Controller
5	1/4" OD Through-Wall Coupling	1/4" OD Drain
6	Power Entry Module, 20 Amp	System Main Power Connection
7	60# Storage Tank	Integral Nitrogen Storage Tank

Figure 6: FPS-1250 Dimensions and Connections

#### 4.6 AIR BYPASS SETUP (OPTIONAL)

The Air Bypass Option ensures that nitrogen is the only supervisory gas entering the FPS. It safeguards your installation all while providing piece of mind knowing the FPS is being filled with nitrogen vs any other gas. It will alarm if the N<sub>2</sub>-Blast Generator is being bypassed by the air compressor. It safeguards against a maintenance technician from inadvertently leaving the "air bypass" open or the N<sub>2</sub>-Blast being powered in the off position. It will provide a visual alarm when it is in alarm mode. See wiring diagram and installation drawing included with this package. For electronic copies, please contact your local distributor.

#### 4.7 START-UP PROCEDURES

It is necessary to use caution when working with pressurized gas, making sure that all fittings and gas lines are installed correctly. Always leak check (see **Checking for Leaks** section) every line before using the system.

**Note: Line leaks will cause the N<sub>2</sub>-BLAST<sup>®</sup> to run excessively, shortening its life and cause excess wear on the compressor.**

The installation layout drawings are provided with your system in the documentation package of the system. For electronic copies, please contact your local distributor. Review and make sure the setup installation is completed per the installation layout drawings. Ensure that you follow the correct installation drawing per your system's design. In some cases, a N<sub>2</sub> Bypass system for pre-filling is required in the installations to meet code.

If your system requirements are more complex, please consult your sales representative or equipment installer for more detailed installation instructions.

1. The N<sub>2</sub>-BLAST<sup>®</sup> is supplied with ½" NPT Female inlet and outlet fittings. Make sure to use Teflon tape or similar on all fittings to make sure they don't leak.
2. Install the "Supply Line" coming from the air compressor to the N<sub>2</sub>-BLAST<sup>®</sup>'s Air Inlet.
3. Connect the N<sub>2</sub>-BLAST<sup>®</sup> to the storage tank and then to the systems Air Maintenance Device(s).
4. Once connections are made and the air compressor is on, you can slowly open the System's On/Off Valve.
  - a. You will hear air rushing through the system and N<sub>2</sub> filling the FPS system.
  - b. If you hear a leak or have a bad connection, shut the valve off and

- make the correction.
- c. If there is a leak within the unit, remove the cover and locate the issue. If you must replace any parts, only use factory parts supplied from your distributor or South-Tek Systems. Consult the factory if there are any questions.
5. Once the *N<sub>2</sub>-BLAST<sup>®</sup>* fills the 100# storage tank to 70 PSIG, the system will enter standby – the system’s green N<sub>2</sub> Production light will change to orange indicating that the system is in standby. This will shut the air flow off through the generator and eventually shutting off the air compressor once it reaches air tank cutout pressure.
    - a. This will save air and time on your compressor’s motor.
    - b. This also prolongs life of nitrogen generator’s media and filter life.
      - i. Lesser quality systems have a constant purge flow through their systems which decreases system life and increases the need for maintenance.
  6. When you draw N<sub>2</sub> off the system and the tank pressure falls below cut-in pressure (approximately 62 PSIG), the pressure switch will trigger the system back into run mode and start recharging the storage tank automatically. The pressure switch is preset at the factory – no field adjustment is required.

#### 4.8 CHECKING FOR LEAKS

When a leak is suspected, first try to listen for leaks and/or spray with soapy water around the connection ports. If a leak is found, isolate the area and relieve any pressure on it prior to working on it. Fix the leaking part and return the system back to operation. If no leak is heard (or visually seen with the soapy water), turn off the unit and try isolating sections to see if there’s a pressure loss. If the BlastOff™ option is included with your unit, the system will alarm indicating that there is a leak in the line. Consult with your installer if you cannot locate the leakage area.

To determine if the leak is within the Generator to the N<sub>2</sub> Storage Tank:

1. With the unit powered on, close off both ball valves on the N<sub>2</sub> storage tank. Note the storage tank pressure.
2. Allow the system to continue running. Within 10 minutes or less, the system should reach the “Standby” mode.
3. Wait for 5 minutes and if the system remains in the “standby” mode, then the leak is after the N<sub>2</sub> Generator. Read the N<sub>2</sub> storage tank pressure and if the pressure has changed, the leak is within the storage tank fittings. If the N<sub>2</sub> storage tank pressure did not change, check the pipe lines in the building for leaks.

4. If the unit goes back into “run” mode, the leak is within the cabinet. Check all the lines going to the blender and back to the tank.

To find the leak within the cabinet:

1. Open the front cabinet door and locate the N2 storage tank.
2. Close off the output ball valve from the tank (upper ball valve on the red manifold).
3. Watch the exterior gauge above the cabinet for 60 seconds. If you see the pressure dropping, the leak is somewhere between the output ports, to the blender (if one is present), and back to the closed off ball valve on the tank. Fill and/or listen for leaks and fix them once found. If the pressure is not dropping go to the next step.
4. With the unit still running, close off the input ball valve to the tank (lower ball valve on the red manifold).
5. Within 5 minutes, the system should go into “Standby” Mode. If it doesn’t, contact your local provider/installer for further assistance.
6. Once in “Standby” mode, wait 60 seconds. After 60 seconds, the system should remain in “standby” mode. If it doesn’t, the leak is somewhere between the check valve and the output ball valve on the tank.
7. If the system remains in standby, contact your local provider/installer for further assistance.

## **4.9 ACCESS CONTROLS**

Do not attempt to modify the program or the warranty will be voided. In case of the program failure, first attempt to cycle the power to the system. If that does not work, please contact your provider for further instructions.

## **4.10 STARTING THE SYSTEM**

To start the system, turn on the power switch and make sure any valves to the gas lines are in the open position.

## **4.11 STOPPING THE SYSTEM**

To stop the system, close off any valves on the gas lines. Powering down the system is not necessary. If emergency shut off is required, turn off the power switch on the side on the control panel.

## 5 SYSTEM USAGE

### 5.1 INSTRUCTIONS

The FPS-650 and FPS-1250 is intended to be used to generate Nitrogen, and provide nitrogen for the fire protection piping system. Follow the installation instructions above and only use in an approved environment. The generator generates enough nitrogen to maintain zone pressure requirements. Please consult with your local provider for questions not answered in this manual.

The system is design for 24-hour operation, but routine maintenance on the filters must be performed. See section "System Maintenance" for detail maintenance instructions.

### 5.2 ALARM NOTIFICATION

#### Filter Alarm:

All FPS-650 and FPS-1250 comes standard with a "Filter Alarm" notification. The controller will display "**FILtr**" message in red when the filter change is overdue. It is recommended that the filters be changed once every year or every 1000 hours, whichever comes first. See section "System Maintenance" for detail maintenance instructions.

#### BlastOff™ - Leak Detection System Alarm

An optional feature that can be included with the system is the BlastOff™ - Leak Detection System. It is a patented system when installed into the FPS-650 and FPS-1250 detects line leaks within the downstream gas lines from the N2 Generator to the FPS piping. Line leaks could be due to pin hole leaks in the pipe lines, loose fittings, faulty connection, etc. These leaks are potential safety hazards, they can cause the nitrogen to deplete quickly, and could cause your FPS-650 and FPS-1250 to run in excess (decreasing the life of the unit).

Once a leak has been detected, the BlastOff™ is set to initiate a buzzer, displays "**b OFF**" in red on the controller screen, and shuts off the FPS-650 and FPS-1250 until the problem has been remedied. To reset the BlastOff™, simply turn off the FPS-650 and FPS-1250 and turn it back on. The FPS-650 and FPS-1250 can be ordered with the BlastOff™ System Factory installed or the system can be retrofitted in the field. Some rewiring is required to field install.

Never reset repeatedly; if the BlastOff™ goes off daily, there is a potential issue. Consult your installer for a solution. The label on the next page will be on your FPS if factory installed.

### Buzzer or Red Light Warning Indicator

This N2-BLAST® is equipped with **The BlastOff® Leak Detection Feature**. If the light on the PLC screen is blinking “bōFF” in red and buzzer is on, you may have a leak in your fire protection system piping. **Protocol:** Power off the N2 Blast® and check for a leak. If none are found leave the unit turned off and contact your service company. Only once the leak has been located and corrected should you resume normal operation.

Blastoff®

## 6 SYSTEM MAINTENANCE

Whenever doing any maintenance to the system, make sure to power down the system. Remove the front cover to gain access to the filters.

### Annual Filter replacement kit part # FRP-007

#### Air Pre-Filter

The integrated Air Compressor has an air intake pre-filter. It is designed to prevent particles from entering the compressor housing and damaging internal components. This filter needs to be replaced once per year or every 1000 hours, whichever comes first. To do so, remove the pre-compressor filter cap by twisting it clockwise. Remove the old element and use a clean dry cloth to clean the filter bowl before installing the new element.

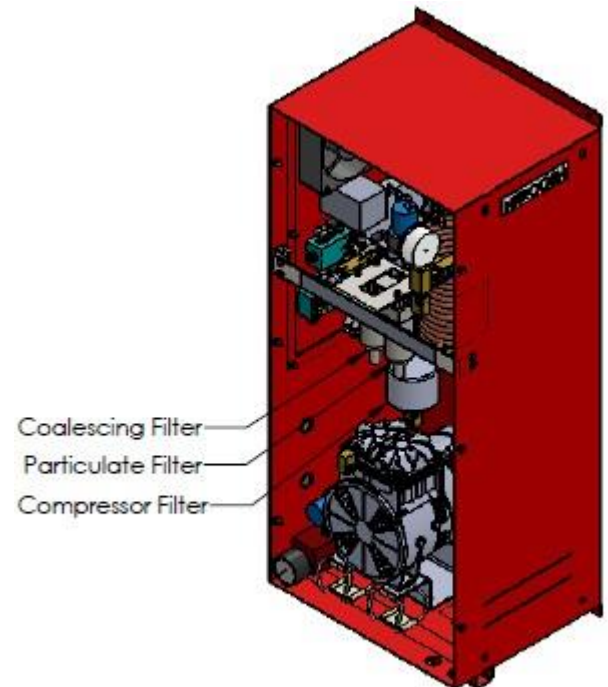

Figure 7: FPS-650 Filter Change

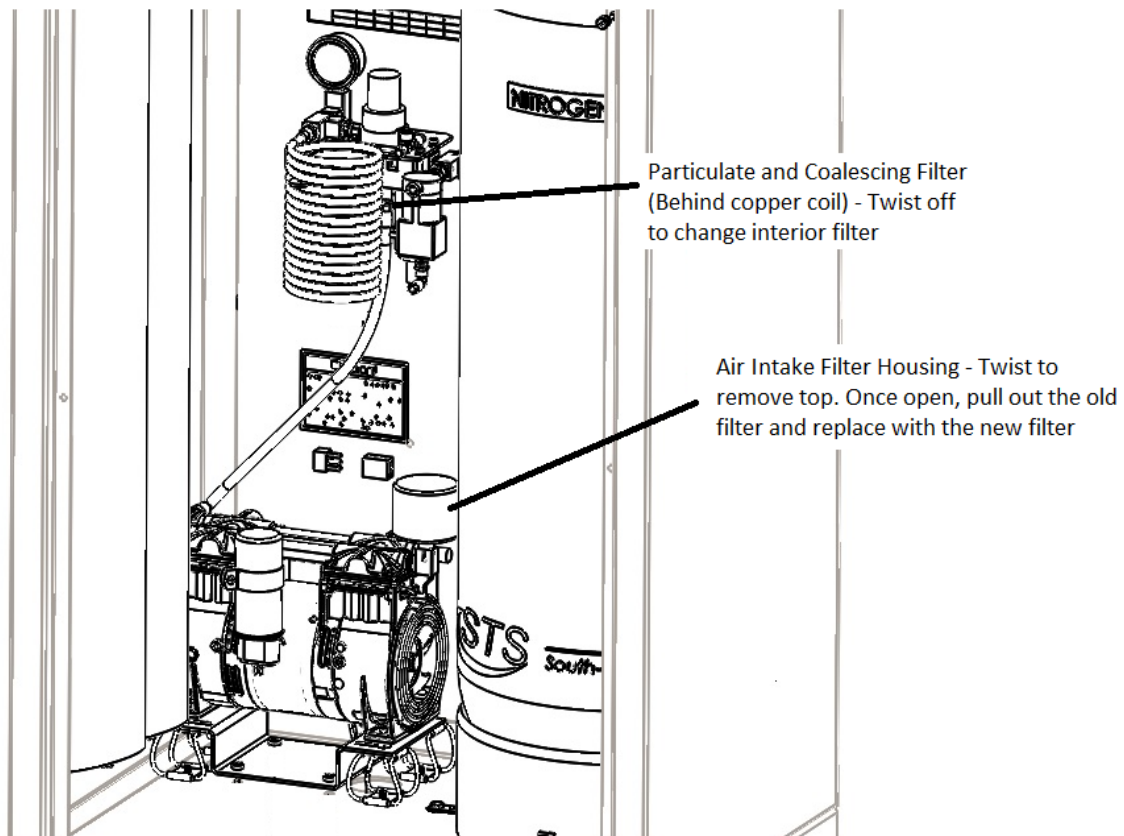

Figure 8: FPS-1250 Filter Change

### Particulate and Coalescing Filter

The particulate and coalescing filter after the air compressor is designed to capture particulate and moisture prior to entering the rest of the system. These filters need to be replaced once per year or every 1000 hours, whichever comes first. To do so,

1. Make sure there is no pressure on the filter bowls. The gauge after the filter bowl will read 0 PSIG to indicate that there is no pressure on the bowl.
2. Unscrew the filter bowls by turning them counterclockwise.
3. Once the filter bowls have been removed, rinse any debris out of the bowls with warm water.
4. Dry the bowls with a clean dry cloth and replace the old O-rings with the ones provided in the kit.
5. Using a Philips-Head screwdriver, remove the particulate element and replace.

6. The coalescing element can be removed by turning it counterclockwise with your hand; then replaced with the new element in the reverse order.
7. Once both elements have been replaced, bowls have been cleaned and O-rings replaced, the bowls can be screwed back into their corresponding filter housings.

Once all the filters have been replaced, press and hold the filter reset button on the electrical panel, an audible beep will confirm the reset. To use the Filter Change Reset Button on the face of the controller, the controller must be unlocked (press and hold Mode button to lock and unlock). Put the front cover back on the cabinet and power the unit back on. Once powered up, you should hear the air compressor turn on, the FPS-650 and FPS-1250 will be producing nitrogen. Be sure to check the filter bowls for leaks.



Alarm Simulation Button

Filter Change Reset Button

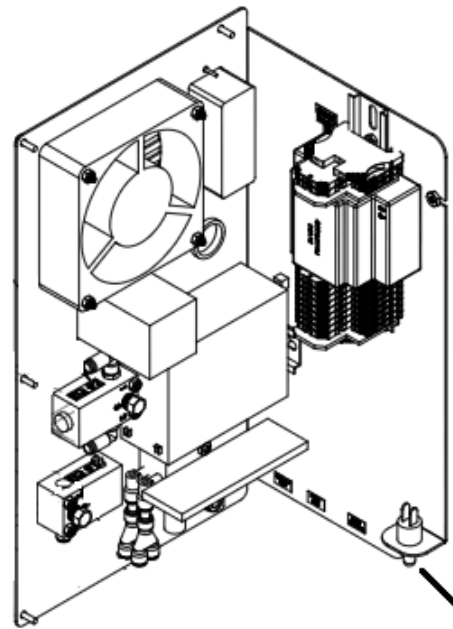

Filter Reset Button

Figure 9: Filter Reset Button

## 7 KEY CONTACTS

Contact your local provider/installer for any questions with the performance and/or maintenance of the system. They will be best suited to answer your questions and your quickest solution on any issues you may have.

## 8 FAQs

### 8.1 POWER ISSUES

If the FPS-650 and FPS-1250 does not have power, the production and storage of nitrogen will become apparent once the storage pressure drops.

1. Check the power cord
2. Has building's circuit breaker or GFCI tripped? Locate the breaker and reset. If breaker continues to trip, you may have that circuit overloaded.

### 8.2 PRESSURE ISSUES

The FPS-650 and FPS-1250 will produce and store Nitrogen at 70 (+/-5) psig. Once the storage tank reaches 70 (+/-5) psig, the system will go into Stand-By Mode. When the pressure drops by about 7-10 psig, the system should go into Operation Mode and begin to refill the storage. If you are out specifications, we need to determine where the issue is. Contact the manufacturer or factory trained technician.

#### Nitrogen Pressure Check:

Look at the pressure gauge on the top of the cabinet. It should be between 50 and 80 psig. If the pressure is low, a few things need to be checked.

- Check the power.
- Check leaks throughout system. Refer to section "Checking for Leaks".

### 8.3 GAS LEAKS

As with any gas system, only use a spray bottle on non-electrical equipment to find leaks. Fix or replace leaking fittings or old hose. Push-to-connect fittings will show bubbles and typically have up to a 5ccm acceptable leakage rate. Contact your local provider/installer for help.

#### 8.4 BLASTOFF™ - LEAK DETECTION SYSTEM:

“There is an alarm sounding in the FPS-650 and FPS-1250 and the control panel has ‘**b OFF**’ illuminated on the side panel of the unit.”



If you hear the alarm and the “**b OFF**” is displayed on your unit, it means that it is equipped with “*The BlastOff™ - Leak Detection*” feature. If the buzzer is on, there may be a leak in one of the sprinkler lines, AMD, or fittings may not be properly seated, causing leaks. Note: Turn off this unit’s on/off power switch and check for leaks. If none are found, leave the unit turned off and contact your Service Technician. Once the leak has been fixed, turn the N<sup>2</sup> Blast™ on/off rocker switch back “On” to resume normal operation. By turning the system power off, then back on, this will reset the BlastOff™ automatically.

## APPENDIX A: WARRANTY

The FPS-650 and FPS-1250 System is warranted against any defects in workmanship and materials for 12 months (or 1000 hours) from the date of shipment from South-Tek Systems, whichever comes first. The purchaser has the liability to ensure that the system is fully inspected upon delivery and shall contact the appropriate shipping company to make any claims on damaged goods due to transit within that shipping company's policies. If the system is received with defects that are not due to shipping, a written claim should be submitted to South-Tek Systems within 1 week of receiving the shipment. South-Tek Systems can deny all other claims at their discretion.

All warranty work shall be done at a South-Tek System facility or at a FPS-650 and FPS-1250 Authorized Service Center. Only factory trained and authorized personnel are covered under warranty. Any part that is returned / repaired / replaced under warranty may be remanufactured or changed to a different specification at the factory's option. Any work performed by an unauthorized person/company or usage of non-factory parts, may void all warranties to the product.

Any item not manufactured by South-Tek may carry its own warranty from its manufacturer and will be warranted by that manufacturer. All parts that need to be returned should be announced. Any item(s) that is returned to South-Tek Systems without an RMA number (return authorization number) may be denied and returned to the sender. Contact the factory for RMA #'s, prior to return shipment.

South-Tek Systems is not liable for damages caused by normal wear and tear, water, fire, erosion, corrosion, explosion, misuse, oil/gas vapors or unauthorized modifications. South-Tek Systems is also not liable for any losses (including CO<sub>2</sub>), damages, or cost of delays, including incidental or consequential damages. There are no warranties or guarantees, expressed or implied, including the warranties of merchantability or fitness for a particular purpose or use, other than those warranties expressed herein.

For Claims, contact South-Tek Systems, LLC. at:

Tel: (888) 526-6284 Fax: (910) 332-4178

Email: [services@southteksystems.com](mailto:services@southteksystems.com)

Or write to:

South-Tek Systems, Warranty Claims, 2940 Orville Wright Way, Wilmington, NC 28405

## APPENDIX B: Internal Quick Fill Compressor Option for FPS-1250

### Electrical Connection

When connecting to the 1.9 HP Internal Quick Fill Compressor, always ensure site and local regulations are followed

The Internal Quick Fill Compressor requires 110-240VAC / 60hz / 1ph.

**Note:** Utilizing supply voltages differing from your specified model requires reconfiguration of wiring. Please contact your supplier.

### Over-Current Protection Device (OCPD)

The compressor features an internal thermal overload which may be reset manually on the back of the compressor if tripped, but an over-current and short-circuit protection disconnect rated for the motor is required. Always refer to local and site regulations during electrical installation.

### Compressor Disconnect

For easy operation of the compressor, a disconnect rated for a 20A or more motor load is recommended to turn on and off the Internal Quick Fill Compressor. It is suggested that the disconnect is placed within sight of the nitrogen generator. The compressor will run continuously if no such disconnect is put in place. Always refer to local and site regulations during electrical installation.

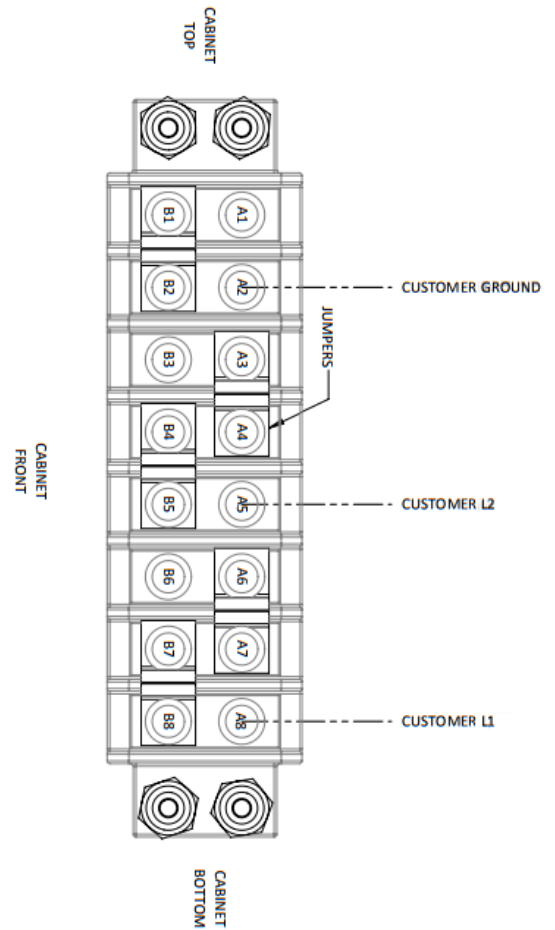

**Compressor Motor Nameplate**

HORSEPOWER: 1.9	DUTY: CONT.
RPM: 3450	S.F.: 1.0
PH: 1     HZ: 60	CODE: N
VOLTAGE: 120/240 VAC	INS. CL.: F
AMB: 40°C	F.L.A.: 15/7.5
FR.: 56Y	BRG: BALL
ENCL.: DP	DE: 6204DDU
	ODE: 6203DDU

**Operation Instructions**

For proper operation of the Internal Quick Fill Compressor, first switch the generator to bypass mode using the 3-way ball valve mounted atop the unit. For the generator to be in Bypass Mode the ball valve handle must be in the fully upright position.

Once generator is in Bypass Mode and the system is ready for filling, turn on the compressor using the external disconnect. Once system is done filling, switch the generator back to Normal Operation Mode by turning the ball valve handle horizontal. After the generator is back in Normal Operation Mode, shut down the compressor with the external disconnect.

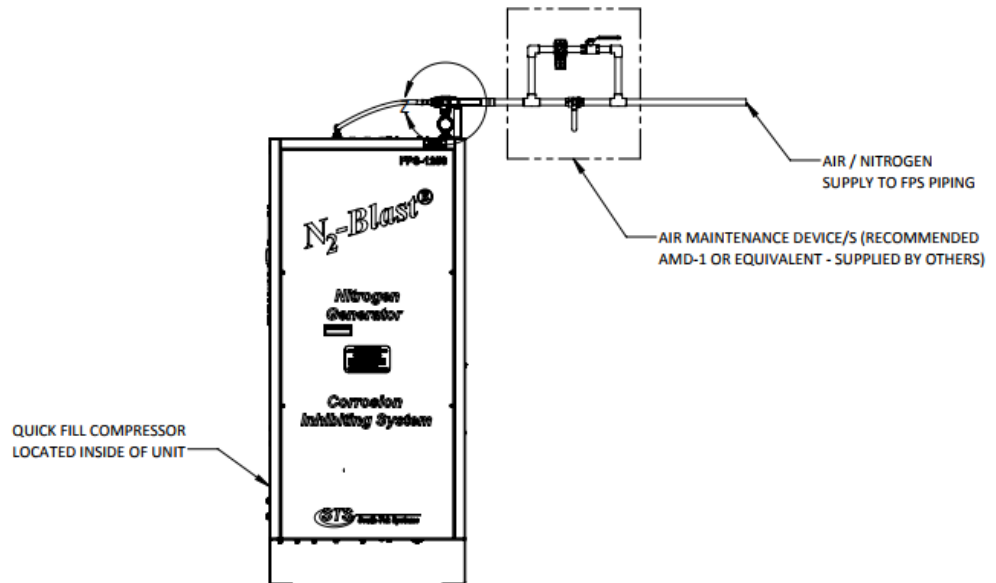

-----Last Page-----