

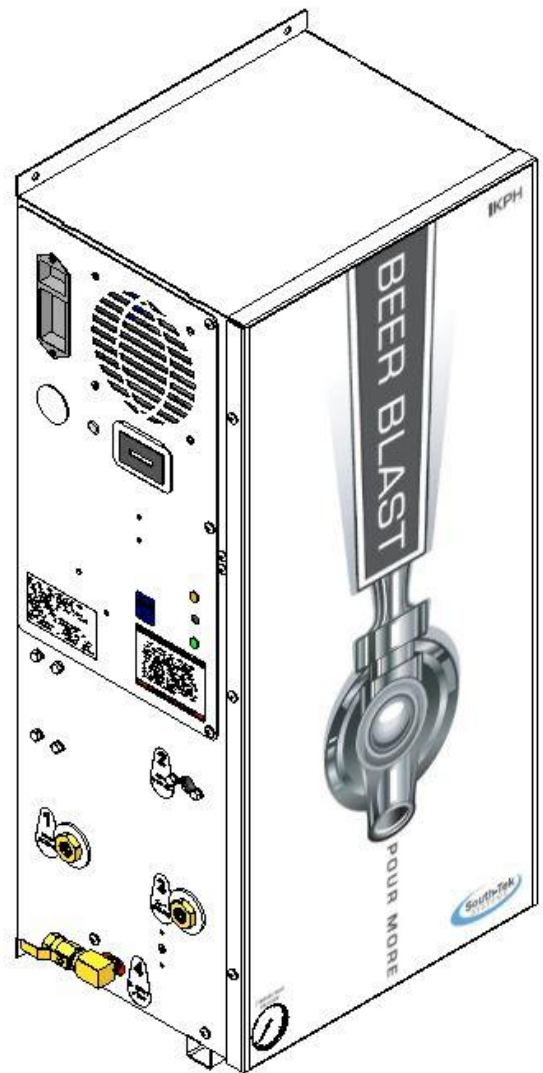

BEERBLAST™ 1KPH & N2-GEN™ 1KPH O&M MANUAL

Revision 0

Date 04/20/18



VERSION HISTORY

Revision #	Implemented By	Revision Date	Approved By	Approval Date	Reason
0	Kyle Mellott	04/11/18	M. Thomas	04/20/2018	Initial Release

TABLE OF CONTENTS

1 INTRODUCTION	5
1.1 Purpose	5
1.2 Audience	5
1.3 Important Information	5
2 SAFETY GUIDELINES	6
2.1 General	6
3 SYSTEM DESCRIPTION	8
3.1 Key Features	8
3.2 Specifications (BeerBlast™ 1KPH)	9
3.3 System Operations	9
4 PRODUCT INSTALLATION	10
4.1 Unpacking and Preparation (BeerBlast™ 1KPH)	10
4.2 Electrical Requirements	10
4.3 Mounting (BeerBlast™ 1KPH)	10
4.4 Installation (BeerBlast™ 1KPH)	12
4.5 Nitrogen Cylinder Back-Up (BeerBlast™ 1KPH)	15
4.6 Start-Up Procedures (BeerBlast™ 1KPH)	15
4.7 Checking for Leaks	16
4.8 Access Controls	17
4.9 Starting the System	17
4.10 Stopping the System	17
5 SYSTEM USAGE	18
5.1 Instructions	18
5.2 Alarm Notification	18
6 SYSTEM MAINTENANCE	19
7 KEY CONTACTS	21
8 FAQs	21
8.1 Power Issues	21
8.2 Pressure Issues	21
8.3 Gas Leaks	22
8.4 BlastOff™ - <i>Leak Detection System</i> :	22
APPENDIX A: WARRANTY	23

-----Notes-----

1 INTRODUCTION

1.1 PURPOSE

The BeerBlast™ 1KPH / N2-GEN™ 1KPH provide an economical, precise means of supplying mixed beer gas to “push” the beer to the tap within restaurant and bar establishments. Beer brewers have established recommended Carbon-Dioxide (CO₂) and Nitrogen (N₂) mixed gas ratios to protect the kegged product quality, eliminating over-foaming or under-carbonation, while increasing the keg life. Precise mixed beer gas lowers operational costs, increases yields/profits, and ultimately provides a higher level of customer satisfaction. This system can also be used for wine or specialty mixed drink dispensing systems.

South-Tek System’s line of BeerBlast™ 1KPH / N2-GEN™ 1KPH products consist of two or three main parts: a nitrogen generator, a compressor, and CO₂/N₂ dual-output gas blender (the N2-GEN™ 1KPH does not come with an integrated gas blender). Since air is comprised of ~79% N₂, we can easily and cost-effectively separate the N₂ from the air. The N₂ is “generated” by our pressure swing adsorption (PSA) technology, where compressed air cycles back and forth between two beds. As needed, the high purity N₂ is then forwarded to the integral McDantim™ dual-output gas blender (only in the BeerBlast™ 1KPH) which precisely blends the N₂ with the CO₂ from the restaurant/bar’s in-house storage cylinder/tank. The standard CO₂/N₂ blends available are 60%/40% and 25%/75%. The blends are accurate to within 2%. Custom CO₂/N₂ blends are available if desired.

**The installer and the user should read this manual in its entirety.

1.2 AUDIENCE

This manual is intended for Installer/Restaurant/Bar Operator/Supervisory Staff and should be read in its entirety prior to operation.

Please contact your local gas provider with any operation or maintenance questions prior to contacting the manufacturer.

1.3 IMPORTANT INFORMATION

Before personnel attempt to service the unit, ensure the power switch has been turned to the off position, then disconnect the unit’s external power cord from the building electrical power supply if possible. When servicing your system, always follow the instructions in the manuals provided by South-Tek Systems (STS).

2 SAFETY GUIDELINES

2.1 GENERAL

Correct use of the BeerBlast™ 1KPH / N2-GEN™ 1KPH is important for your personal safety and trouble-free operation of the BeerBlast™ 1KPH / N2-GEN™ 1KPH. Incorrect use can cause damage to the BeerBlast™ 1KPH / N2-GEN™ 1KPH or lead to incorrect gas supply.

The BeerBlast™ 1KPH / N2-GEN™ 1KPH produces Nitrogen (N₂) at a low flow rate, which quickly dissipates into the air. N₂ gas is not poisonous, but should not be directly inhaled, since in high concentrations, it can cause asphyxiation. **Ensure that the unit is installed within a well-ventilated room that is not sealed off from normal living space air changes.**

All personnel involved with installation, operations, and maintenance of the BeerBlast™ 1KPH / N2-GEN™ 1KPH must follow safe working practices, OSHA, and local health/safety code regulations during the installation, operation, and maintenance of the unit.

Read carefully and act accordingly before installing, operating, or repairing the unit.

- Operator must use safe working practices and rules when operating the nitrogen generator.
- The owner is responsible for keeping the unit in safe operating condition at all times.
- Always use approved parts when performing maintenance and repairs. Make sure that replacement parts meet or exceed the original parts' specification.
- Only authorized, trained, and competent individuals are allowed to perform installation, operation, maintenance, and repair.
- Completely isolate incoming and outgoing pressures to the generator, and make sure to depressurize the service/repair section prior to performing any mechanical work, including changing the filters. The nitrogen generator's exhaust gas and/or any venting gas must be vented to the outside or to a large, well-ventilated room to avoid suffocation due to lack of oxygen.
- Safety glasses should be worn if the cabinet door is open while the machine is operating.
- Use ear protection when the equipment is operating.

WARNING: Pressurized gases are contained within the generator, the receiver, and product tanks. Pressurized gases are dangerous and may cause injury or death if handled or used inappropriately.

- Never allow pressurized gas to exhaust from an unsecured hose. An unsecured hose may exhibit a whipping action, which can cause serious injury. If a hose should burst during use, immediately close all isolation valves if it is safe to do so and power down the unit.
- Never disable or bypass any safety relief valves.
- Always make certain that the nitrogen generator is disconnected from the supply power prior to performing any electrical work.

NOTE: Always following local and site safety regulations in conjunction with this manual. Warning:

- This manual must be read in its entirety prior to installing and operating the BeerBlast™ 1KPH / N2-GEN™ 1KPH to prevent accidents and damage to the BeerBlast™ 1KPH / N2-GEN™ 1KPH.
- Contact your supplier if you detect a problem that you cannot solve with the help of this manual.
- Only use the BeerBlast™ 1KPH / N2-GEN™ 1KPH in accordance with its designed purpose.
 - This system should be limited specifically to beverage applications of beer, coffee, wine, tea and other mixed drink applications and should be kept out of the splash zone.
- Only service-engineers that are qualified to work on electric and pneumatic equipment are allowed to perform the installation, maintenance and repairs. Unqualified people are not allowed to repair the equipment.
- Do not tamper or experiment with the equipment or exceed the technical specifications.

3 SYSTEM DESCRIPTION

3.1 KEY FEATURES

The BeerBlast™ 1KPH / N2-GEN™ 1KPH key features include the following:

- Air Compressor
- Air Filters
- Pressure Swing Adsorption (PSA) Beds
- Safety Relief Valves
- N₂ Storage Tank
- Automatic Pressure Cut-in/Cut-out
- McDantim™ Dual Output Gas Blender (optional)
- STS Patented BlastOff™ - *Leak Detection System*

Air Compressor:

The air compressor is designed internally to the cabinet and features an engineered dampening system to reduce vibration and noise throughout the cabinet. It is an oil-less compressor with a pre-filter attached to the air input. The recommended replacement on the pre-filter is 1,000 run hours or 1 year (whichever comes first). Dirtier environments may require more frequent filter replacements. Consult your supplier for a more frequent filter maintenance schedule if the generator is installed in a dirty environment.

Air Filters:

The generator has two filters after the air compressor; the particulate and coalescing. The Particulate has a 5 micron filter that will catch any of the larger particles. The Coalescing has a 0.1 micron filter that will catch the remaining smaller particles. Both filters feature an auto-drain that will drain the water captured after the air compressor. The drain is plumbed to the outside of the cabinet so that the end-user can connect ¼" tubing and drain to a safe location.

Pressure Swing Adsorption (PSA) Beds:

The generator fills and drains a set of vessels containing a special material which allows high purity nitrogen to pass through and fill the nitrogen storage tank.

Safety Relief Valves:

Safety Relief Valves have been placed throughout the system for maximum safety. They are designed and put in place to minimize failure of other components. They all come with an ASME stamp.

N₂ Storage Tank:

A N₂ Storage Tank is required and sold separately with manual ball valves and gauge.

Automatic Cut-In/Out:

The generator comes with a built-in pressure switch. This will decide when to put the system in "Standby" when the tank is full of nitrogen and when to turn the generator back on.

McDantim™ Dual Output Gas Blender (optional):

Precisely blends N₂ with CO₂ from the restaurant/bar's in-house storage cylinder/tank. The available standard CO₂/N₂ blends are 60%/40% and 25%/75%. The blends are accurate to within 2%. Custom CO₂ /N₂ blends are available if desired.

Patented BlastOff™ – *Leak Detection System*:

The BlastOff™ - *Leak Detection System* will provide the end-user with an alarm when it detects characteristics of a leak somewhere along the beverage lines/system. It will trigger an audible alarm, red light, and the end-user can tie into the dry contact (optional) so that the alarm can be relayed back to an external alarm.

3.2 SPECIFICATIONS (BEERBLAST™ 1KPH)

BeerBlast™ 1KPH – Specifications	
Nitrogen Purity	99.8+%
Kegs per Hour	1
Installation	Wall Mounted
Display	Hours/Power on/Operating/Standby
N ₂ Storage Pressure	60-70 PSIG
CO ₂ Gas	60-80 (min/max) PSIG (Only in BeerBlast™ 1KPH)
Available Blends	60/40 & 25/75 (CO ₂ /N ₂) *Factory Set, Not Field Adjustable
Blend Outlet Pressure	40-50 PSIG min (Only in BeerBlast™ 1KPH)
Outlet Port Connections	1/4" NPT Female
Electrical	110 or 220VAC / 50-60Hz / 1Phase; 20 Amp Breaker
Compressor	Integral / Oil-Free
Ambient Temperature	40° to 85°F
Noise Level (dB)	< 60 dB
Size	12.75" W x 12" D x 27" H (Cabinet Dimensions)
Weight	75 lbs

3.3 SYSTEM OPERATIONS

The system has two standard run modes – Run and Standby. When the power switch is turned on, the indicator lights on the left side electrical panel will illuminate depending on what stage the generator is in; if the green light is illuminated the generator is in run mode, if the amber light is illuminated the generator is in standby waiting until the storage tank drops to the cut-in pressure.

“Run” mode is when the BeerBlast™ 1KPH / N2-GEN™ 1KPH is producing nitrogen and feeding it into the storage tank. The system will automatically enter “Standby” mode when the tank is fully pressurized (65-75 psig). It will remain in “Standby” mode until the tank pressure falls 7-10 psig.

4 PRODUCT INSTALLATION

4.1 UNPACKING AND PREPARATION (BEERBLAST™ 1KPH / N2-GEN™ 1KPH)

The BeerBlast™ 1KPH / N2-GEN™ 1KPH is packaged in a cardboard box, should be carefully opened, and all parts should be inspected for damage upon receipt. Identify and verify that all parts listed on the packing list are present and undamaged. STS is not responsible for damages that have occurred during the shipping and handling of the BeerBlast™ 1KPH / N2-GEN™ 1KPH. Any visual damages should be immediately documented and reported to the shipping company responsible. After the shipping company has been notified, contact STS at (888) 526-6284 to assess the damages.

Until Installation:

- Store the BeerBlast™ 1KPH / N2-GEN™ 1KPH in a dry and climate controlled (60-80°F) room.
- Always keep the BeerBlast™ 1KPH / N2-GEN™ 1KPH in an upright position, or in box as shipped.
- Do not connect the AC power cable until this manual has been read completely and all connections are made as stated within.
- Keep all gas lines dry so that moisture does not enter the generator upon hookup.
- Never place or stack objects on top of the BeerBlast™ 1KPH / N2-GEN™ 1KPH.

4.2 ELECTRICAL REQUIREMENTS

The BeerBlast™ 1KPH / N2-GEN™ 1KPH requires 110 or 240V / 50-60 hz / 1ph connection depending on which voltage was specified at the time of purchase. It has a built in 20A circuit breaker and a standard 3-prong US power cord is provided for the electrical connection. The system is UL 508A ICP approved. Electrical schematic available upon request. If you are located outside the US and need to select a power cord you will need one with an IEC 60320 C-19 connector and a properly rated plug for your region with a ground.

4.3 MOUNTING (BEERBLAST™ 1KPH / N2-GEN™ 1KPH)

The BeerBlast™ 1KPH / N2-GEN™ 1KPH can be mounted to a wall or placed on a floor. It is recommended that the BeerBlast™ 1KPH / N2-GEN™ 1KPH be mounted to a weight-bearing wall that can support its weight as specified in Specifications (BeerBlast™ 1KPH). If mounted on the floor, it should be fastened in place so that it cannot move or fall over due to vibration. The BeerBlast™ 1KPH should always be installed indoors in an environment between 40° and 85° F in the upright position where it will not be damaged by water or moving equipment. Leave at least 6" on the left side of the cabinet for ventilation. 36" of space is recommended for access to the control panel, tube/pipe connections, and the front cover. There is a ¼" OD tube drain port on the bottom right of the cabinet. This can be plumbed to the nearest site drain.

There is an optional mounting bracket kit (STS Part #: A05-TYP1-WH), that allows you to mount the system on a standard 16" wall stud width. Otherwise, use the mounting holes on the cabinet for mounting the BeerBlast™ 1KPH securely and level, directly to the wall.

Optional Mounting Bracket Kit Procedures

1. All BeerBlast™ 1KPH mounting holes and optional mounting bracket holes are for ¼" screws/anchors.
2. All brackets must be installed in orientation as shown to work correctly.
3. Install the cabinet-mounting brackets on the BeerBlast™ 1KPH first with the provided bolts/lock nuts.
4. Locate the wall-mounting bracket. It is an 18" bracket without the rectangular cutouts and will need to be installed on the wall at the desired height and level. The bracket has 16" center to center holes so the unit can be mounted directly to studs. This bracket will need to be mounted per the diagram below using the appropriate hardware for your type of wall material (wood, sheet metal, masonry, etc.). The 12" bracket that is fastened to the top flange of the cabinet can be hung from the 18" bracket once the

18" bracket has been mounted to the wall. Reference the diagram below to see how the angles are to be oriented on the back of the cabinet in comparison to the wall.

- a. Use the supplied nuts and bolts to attach the upper 12" bracket onto the top flange per the diagram.
 - b. Use the supplied carriage bolts and nuts to attach the 18" lower bracket to the bottom flange, but do not overtighten the nuts yet. After installing the system, you may want to offset the bracket slightly, hence the rectangular slots.
5. Optional: If wall studs are not 16" center to center or you have the need to reinforce the mounting area, a ½" or thicker plywood is recommended to be installed prior to hanging the system. Use best general practices to ensure that the wood and system will be secure at its full weight and remember that it will be vibrating from the compressor running.
 6. Once the mounting brackets are all in place, hang the BeerBlast™ 1KPH cabinet from the top bracket making sure it is centered.
 - a. The cabinet should have at least 4" on either side for breathing/cooling purposes.
 - b. Do not install near heat source or where steam or water is present. Damage to system or bodily harm may result as well as voiding warranty.

Warning: Secure the BeerBlast™ 1KPH to the wall at the top and bottom flanges. Failure to do so could cause damage or bodily injury.

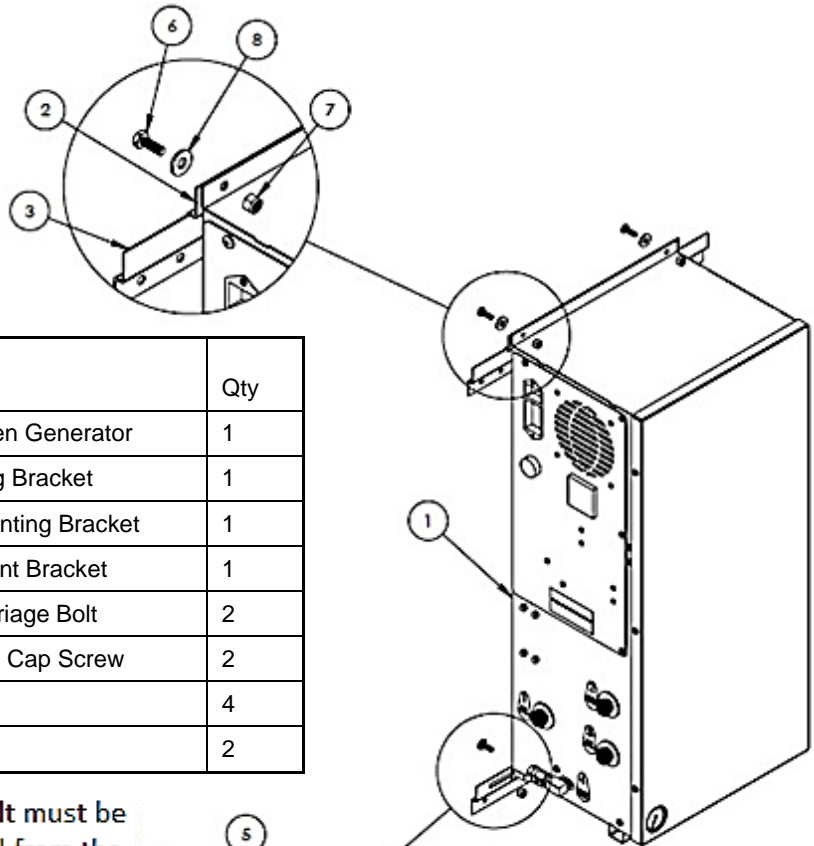

Item #	STS Part #	Description	Qty
1	BB™ 1KPH	BeerBlast 1KPH Nitrogen Generator	1
2	800-133	S-100/200 12" Mounting Bracket	1
3	800-134-B	S-100/200/400 18" Mounting Bracket	1
4	800-129	Type 1 Lower Wall Mount Bracket	1
5	Misc	0.250" -20 x 0.750" Carriage Bolt	2
6	Misc	0.250" -20 x 0.750" Hex Cap Screw	2
7	Misc	0.250" Nylock Nut	4
8	Misc	0.250" Flat Washer	2

Carriage Bolt must be installed from the back side of bracket

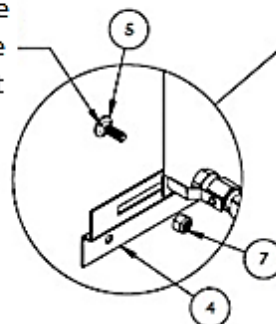

4.4 INSTALLATION (BEERBLAST™ 1KPH / N2-GEN™ 1KPH)

The BeerBlast™ 1KPH is a turnkey system that can be mounted to the wall and connected to the source. If the blender is included, the end user will have to connect the CO₂ to the BeerBlast™ 1KPH. Use caution when working with pressurized gas, making sure that all fittings and gas lines are installed correctly. Always leak check every line before using the system.

Note: Line leaks will cause the BeerBlast™ 1KPH to run excessively, shortening its life.

The BeerBlast™ 1KPH supplies 99.8+% nitrogen as standard, but a gas blend (of N₂ and CO₂) can be added as an option. These lines can be split individually to provide the correct gas and/or blended gas to all of the beverage lines. Use only quality beverage tubing and fittings for all connections. Keep in mind the temperature and pressure requirements when selecting them.

Always install a valve (on/off) on each individual line. This will help with troubleshooting the system. Never detach a line with pressure on it before closing the valve; this could cause damage to the equipment or bodily injury. Also avoid depressurizing the keg at all costs; this will negatively affect the beer quality. Always shut off the valve and remove the tap from the keg before changing or servicing the gas lines.

Two condensate drains for the generator are located on the bottom right of the cabinet. It is the responsibility of the installer to plumb these drains to an area where standing water is trapped or a drain is located. Failure to do so can cause a slipping hazard on the floor below the generator.

If your system requirements are more involved, please consult your sales representative or equipment installer for help.

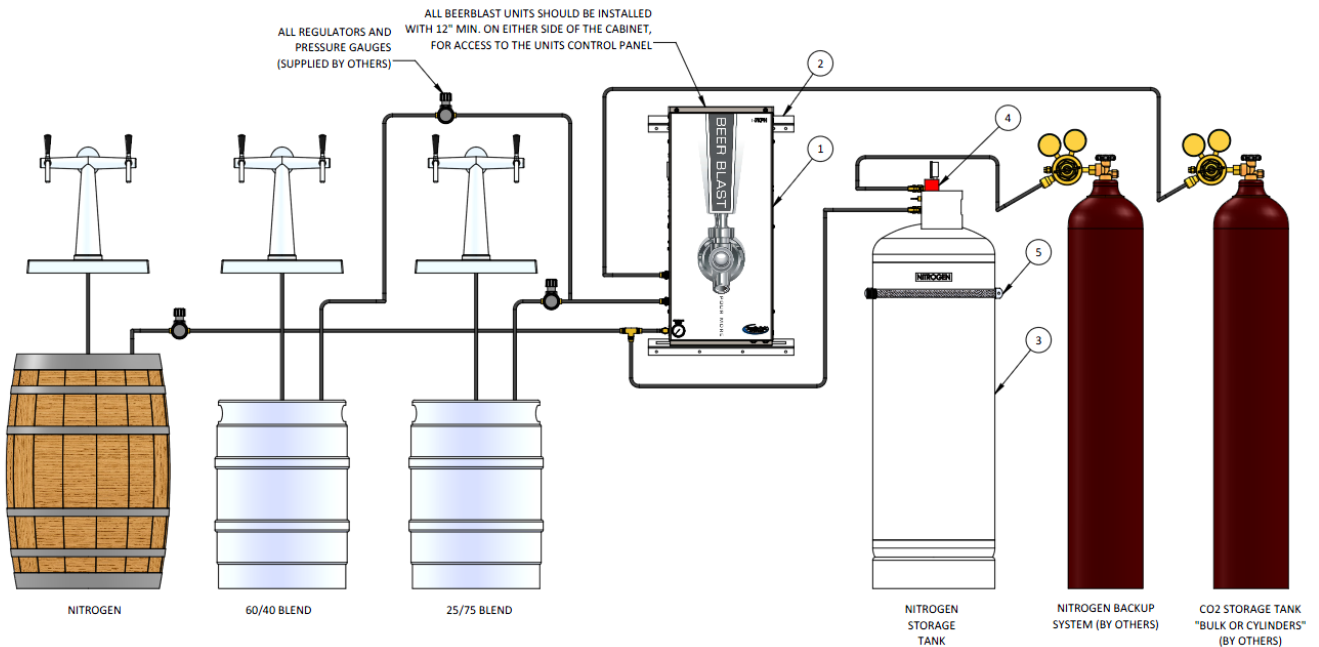

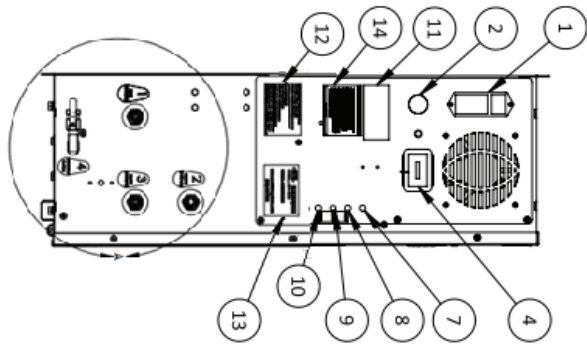

UNIT HAS (4) BOLTS TO LOCK DOWN COMPRESSOR DURING SHIPPING. THESE NEED TO BE REMOVED PRIOR TO POWERING ON UNIT.

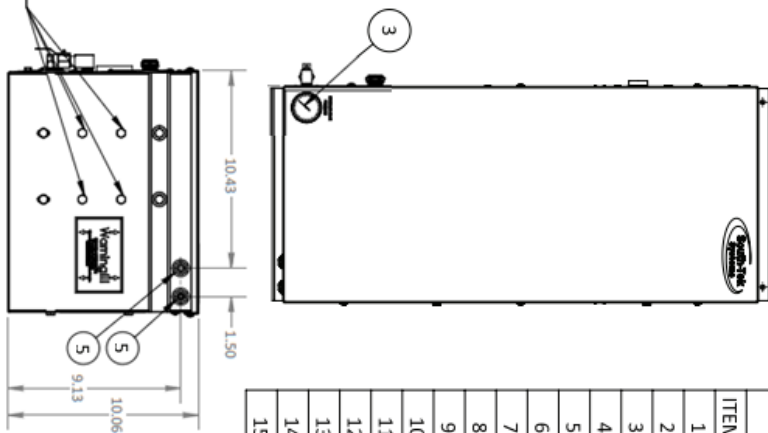

ITEM #	DESCRIPTION	SERVICE
1	POWER ENTRY MODULE, 20 AMP	SYSTEM MAIN POWER SUPPLY
2	AUDIBLE ELECTRIC BUZZER	AUDIBLE ALARM
3	0-100 PSIG PRESSURE GAUGE	N2-STORAGE TANK PRESSURE GAUGE
4	HOUR METER	TOTAL RUN HOURS
5	1/4" OD THROUGH-WALL COUPLING	1/4" OD DRAIN
6	1/4" NPT F BALL VALVE	N2 OUT
7	RED LIGHT	BYPASS INDICATOR
8	AMBER LIGHT	STANDBY INDICATOR
9	RED LIGHT	BLASTOFF INDICATOR
10	GREEN LIGHT	UNIT OPERATING INDICATOR
11	UL 508A OPEN INDUSTRIAL CONTROL PANEL CERTIFICATION LABEL	
12	ELECTRICAL PANEL AND TERMINAL BLOCK TORQUE SPECIFICATIONS LABEL	
13	PRODUCT SERIAL NUMBER LABEL	
14	BUZZER AND DISPLAY SCREEN WARNING INFORMATION LABEL	
15	NITROGEN GENERATOR INFORMATION LABEL	

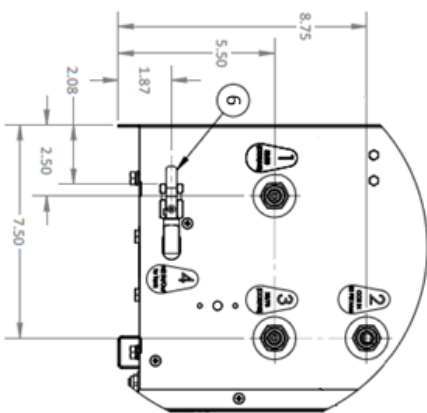

DETAIL A
SCALE 1:4

N2 Storage Tank Setup

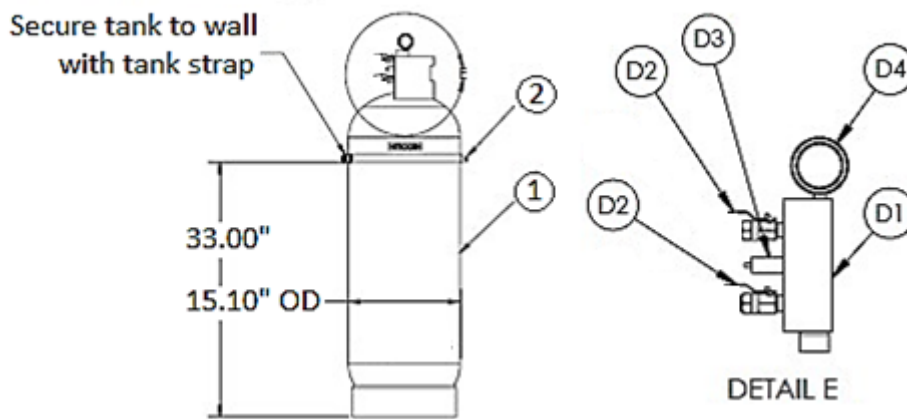

Item #	STS Part #	Description	Qty
1	800-111	100# White Tank w/ Label	1
2	A01-0100-A	100# Tank Strap Assembly	2
3	005-039	Tank Manifold w/ 0.250" Fittings	1

Item #	STS Part #	Description	Qty
D1	800-245-A	Tank Manifold	1
D2	124-308	0.250" NPT M x F Ball Valve, Brass	2
D3	124-335-A	0.250" Safety Relief, 115 PSIG	1
D4	124-125	0.250" NPT x 02.000" 1-160 PSIG Gauge	1

4.5 NITROGEN CYLINDER BACK-UP (BEERBLAST™ 1KPH / N2-GEN™ 1KPH)

It is recommended that a backup system be installed in case of any unforeseen complications. A backup N₂ Cylinder tank can be used instead of the generated nitrogen from the BeerBlast™ 1KPH / N2-GEN™ 1KPH. If the optional gas blender is present, it will allow the nitrogen to go through the blender to achieve the desired results. To install the back-up tank, you will need a cylinder with valve and regulator (regulated to 80 psig). Install the N₂ back-up on the gas line on Port 4 of the BeerBlast™ 1KPH / N2-GEN™ 1KPH as follows:

1. The N₂ back-up cylinder should have a high pressure regulator and ball valve on the output. It is recommended to have a lockable ball valve and/or labeled for "Backup use only".
2. If the Back-up system is turned on, the backup will fill the N₂ Storage tank and flow to the BeerBlast™ 1KPH / N2-GEN™ 1KPH keeping the internal blender pressurized with Nitrogen.

See below for visual piping connections:

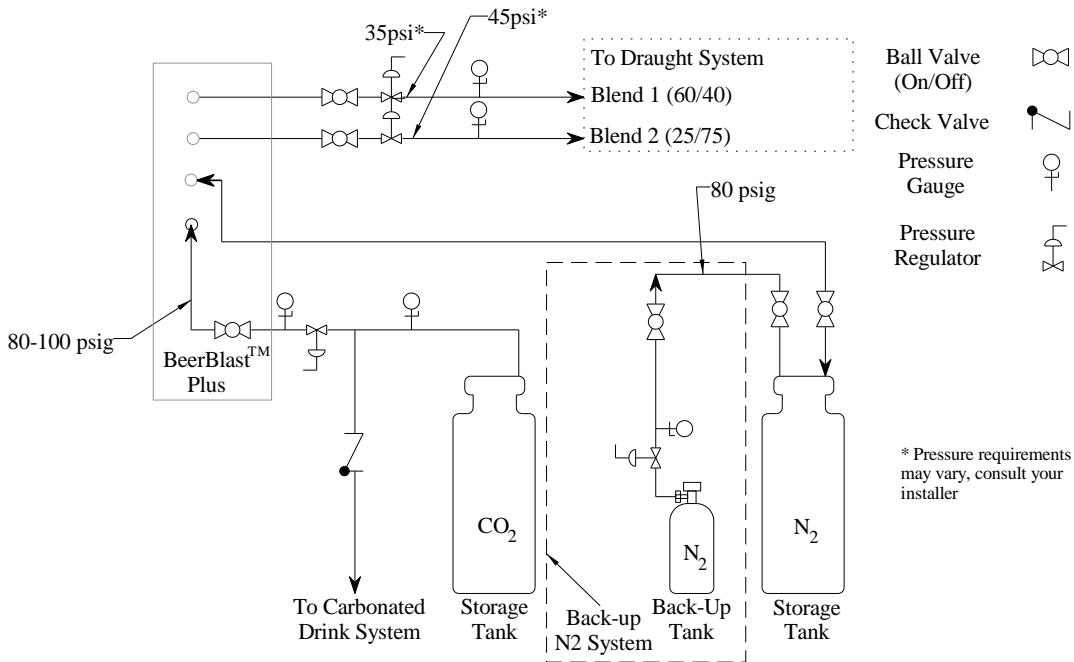

4.6 START-UP PROCEDURES (BEERBLAST™ 1KPH / N2-GEN™ 1KPH)

It is necessary to use caution when working with pressurized gas, making sure that all fittings and gas lines are installed correctly. Always leak check every line before using the system.

Note: Line leaks will cause the BeerBlast™ 1KPH to run excessively, shortening its life and placing excess wear on the compressor.

The installation layout drawings are provided with your system in the documentation package. For electronic copies, please contact your local distributor. Review and make sure the equipment is installed and configured per the installation layout drawings. Ensure that you follow the correction installation drawing per your system's design. In some cases, a N₂ Bypass system for pre-filling is required in the installations to meet code.

If your system requirements are more complex, please consult your sales representative or equipment installer for more detailed installation instructions.

1. The BeerBlast™ 1KPH is supplied with ¼" NPT female inlet and outlet fittings. Make sure to use Teflon tape or similar on all fittings so they do not leak.
2. Connect the BeerBlast™ 1KPH to the storage tank input and then, the output, to the beverage system.
3. Once connections are made, slowly open the system's On/Off Valve.
 - A. You will hear air rushing through the system and N₂ filling the BeerBlast™ 1KPH storage tank.
 - B. If you hear a leak or have a bad connection, shut the valve off and make the correction.
 - C. If there is a leak within the unit, remove the cover and locate the issue. If you have to replace any parts, use only factory parts supplied from your distributor or South-Tek Systems. Consult the manufacturer if there are any questions.
4. Once the BeerBlast™ 1KPH fills the storage tank to 70 PSIG, the system will enter standby – the system's green N₂ Production light will change to orange indicating that the system is in standby. This will shut the air flow off through the generator and eventually shut off the air compressor once it reaches the air tank cutout pressure.
 - A. This will prolong the life of your compressor's motor.
 - B. This also prolongs the life of the nitrogen generator's media and filter.
 - i. Lesser quality systems have a constant purge flow through their systems which decreases system life and increases the need for maintenance.
5. When you draw N₂ off the system and the tank pressure falls below cut-in pressure (approximately 60 PSIG), the pressure switch will trigger the system back into run mode and start recharging the storage tank automatically. The pressure switch is preset at the factory – no field adjustment is required.

4.7 CHECKING FOR LEAKS

When a leak is suspected, first try to listen for leaks around the connection ports. If a leak is found, isolate the area so that there is no pressure on it. Fix the leaking part and return the system back to operation. If no leak can be heard, turn off the unit and try isolating sections to see if there is a pressure loss. If the BlastOff™ option is included with your unit, the system will alarm indicating that there is a leak in the line. Consult with your installer if you cannot locate the leakage area.

To determine if the leak is within the cabinet:

- A. With the unit powered on, close off all output gas. If no ball valve is installed on the output ports, it is recommended to remove the gas lines and install a plug.
- B. Allow the system to continue running. Within 1 hour, the system should reach the "Standby" mode.
- C. Wait for 5 minutes and if the system remains in the "standby" mode, then the leak is after this point. Check the gas lines exterior to the cabinet all the way back to the keg system.
- D. If the unit goes back into "run" mode, the leak is within the cabinet. Check all the lines going to the blender and back to the tank.

To find the leak within the cabinet:

1. Open the front cabinet door and locate the N₂ storage tank.
2. Close off the output ball valve from the tank (upper ball valve on the red manifold).
3. Watch the exterior gauge above the cabinet for 60 seconds. If you see the pressure dropping, the leak is somewhere between the output ports, to the blender (if one is present), and back to the closed off ball valve on the tank. Fill and/or listen for leaks and fix them once found. If the pressure is not dropping, go to the next step.
4. With the unit still running, close off the input ball valve to the tank (lower ball valve on the red manifold).
5. Within 5 minutes, the system should go into "Standby" Mode. If it doesn't, contact your local provider/installer for further assistance.
6. Once in "Standby" mode, wait 60 seconds. After 60 seconds, the system should remain in "standby" mode. If it doesn't, the leak is somewhere between the check valve and the output ball valve on the tank.

7. If the system remains in standby, contact your local distributor/installer for further assistance.

4.8 ACCESS CONTROLS

The built-in control timer is programmed to function without requiring the user to input any values. Do not attempt to modify the timing or the warranty will be voided. In case of a failure, first attempt to cycle the power to the system. If that does not work, please contact your provider for further instructions.

4.9 STARTING THE SYSTEM

To start the system, turn on the power switch and make sure any valves to the gas lines are in the open position.

4.10 STOPPING THE SYSTEM

To stop the system, close off any valves on the gas lines. Powering down the system is not necessary. If emergency shut off is required, turn off the power switch on the side on the control panel.

5 SYSTEM USAGE

5.1 INSTRUCTIONS

The BeerBlast™ 1KPH / N2-GEN™ 1KPH is intended to be used to generate nitrogen to pressurize kegs for draft beer systems. Follow the installation instructions above and only use in an approved environment. The generator generates enough nitrogen to push 1 keg per hour. Make sure that proper regulators, cooler temperature, and line temperatures are maintained, otherwise you will not be able to effectively push beer from the keg. Please consult with your local distributor for questions not answered in this manual.

The system is designed for 24 hour operation, but routine maintenance on the filters must be performed. Reference the "System Maintenance" section for detailed maintenance instructions.

5.2 ALARM NOTIFICATION

BlastOff™ - Leak Detection System Alarm

All BeerBlast™ 1KPH / N2-GEN™ 1KPH models come standard with the patented BlastOff™ - *Leak Detection System*. It detects line leaks within the downstream gas lines from the N₂ Generator to the kegs. Line leaks could be due to a keg not being tapped correctly, a beverage line leak or failing fitting, etc. These leaks are potential safety hazards, can cause the CO₂ to deplete quickly, and could cause your BeerBlast™ 1KPH / N2-GEN™ 1KPH to run in excess (decreasing the life of the unit).

Once a leak has been detected, the BlastOff™ is set to turn on a buzzer, a red light on the side of the generator, and shuts off the BeerBlast™ 1KPH / N2-GEN™ 1KPH until the problem has been remedied. To reset the BlastOff™, simply turn off the BeerBlast™ 1KPH / N2-GEN™ 1KPH and turn it back on. The BeerBlast™ 1KPH / N2-GEN™ 1KPH can be ordered with the BlastOff™ System Factory installed or the system can be retrofitted in the field. Some rewiring is required to field install.

Never reset repeatedly; if the BlastOff™ goes off daily, there is a real potential issue. Consult your installer for a solution. The label below will be on your BeerBlast™ 1KPH if factory installed.

Buzzer or Red Light Warning

This unit is equipped with **The BlastOff™ - Leak Detection** feature. If the red light and buzzer are on, you may have a leak in one of the gas lines or one of your kegs may not be properly tapped, causing gas leaks. **Note:** Turn off this unit's on/off rocker switch and check for leaks. If none are found, leave the unit turned off and contact your service company. Once the leak has been fixed, turn the BeerBlast™ on/off rocker switch back on to resume normal operation.

6 SYSTEM MAINTENANCE

When performing maintenance on the BeerBlast™ 1KPH, make sure to power down the system. Remove the front cover to gain access to the filters. Unscrew the front cover by removing the six 10-32 x ½” pan head screws. Shut down the generator temporarily by turning off the power switch located on the top-left side of the generator.

Annual Filter replacement kit part # [FRP-001](#)

Air Pre-Filter

The integrated Air Compressor has an air intake pre-filter. It is designed to prevent particles from entering into the compressor housing and damaging internal components. This filter needs to be replaced once per year or every 1,000 hours, whichever comes first. To do so, remove the pre-compressor filter cap by twisting it clockwise. Remove the old element and use a clean dry cloth to clean the filter bowl before installing the new element.

Particulate and Coalescing Filter

The particulate and coalescing filter after the air compressor is designed to capture particulate and moisture prior to entering the rest of the system. These filters and seals need to be replaced once per year or every 1,000 hours, whichever comes first. To do so,

WARNING: Do not try to remove filter bowls until the filter is completely depressurized.

1. Disconnect the clear-blue drain tubes from the bottom of the bowls.
2. To remove the bowl, turn the metal casing around the blue plastic filter bowl counter-clockwise until it unscrews completely from the filter housing. Then twist slightly and pull the blue plastic bowl downwards out of the housing.
3. Inspect the bowls. If the drain system is working properly, the bowls should not be full of water.
4. Remove the particulate filter element by pulling the black plastic filter element holder out of the filter bowl and, carefully, twisting the top and bottom piece counter-clockwise until the holder pulls apart. Take notice of how the element looks. If the element is excessively dirty, more frequent filter changes are recommended.
5. The coalescing element can be removed by turning it counter-clockwise by hand; then replace with the new element in the reverse order.

NOTE: A plugged drain system will cause water and oil to carry over into the system, which will cause permanent damage to the media inside the unit. Such damage is not covered by the manufacturer's warranty. Use of filters other than those specified by South-Tek Systems could result in damages not covered by the warranty.

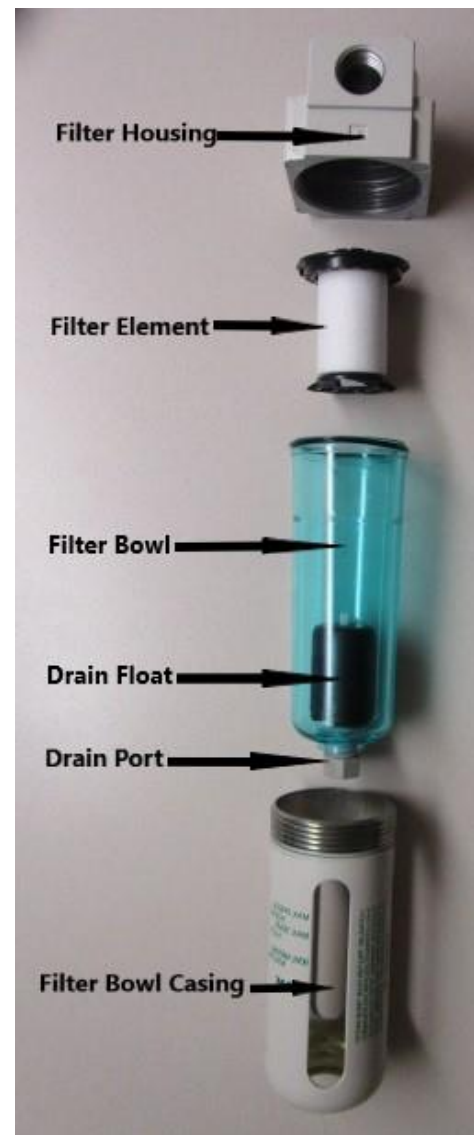

6. Wash the bowls in soapy water and rinse thoroughly as needed. Use of light air gun to remove debris is also acceptable. Make sure to always wipe down with a clean and dry cloth.
7. Install new filter element and replace O-rings as needed.
8. Put the filter bowls back on the system in reverse order of how it was removed making sure the bowl is seated in place correctly. Only tighten metal casing around filter bowl hand tight.
9. Be sure to utilize the filter replacement schedule on the face of the filter bracket to keep track of when the filter was replaced last.
10. Put the front cover back on the cabinet and the unit can be powered up again. Once powered up, you should hear the air compressor turn on and the BeerBlast™ 1KPH / N2-GEN™ 1KPH will resume producing nitrogen.

Proper cleaning

In beverage, restaurant and pub applications this product is certified as an NSF product. To ensure compliance with typical requirements of these environments the product should be cleaned with mild detergent.

Specific to BeerBlast™ 1 KPH models ensure that the lower support channel is clean. Clean with approved kitchen cleaner, apply a rag or brush through the openings as shown with arrows. Keep free from foreign objects, dust, debris and vermin.

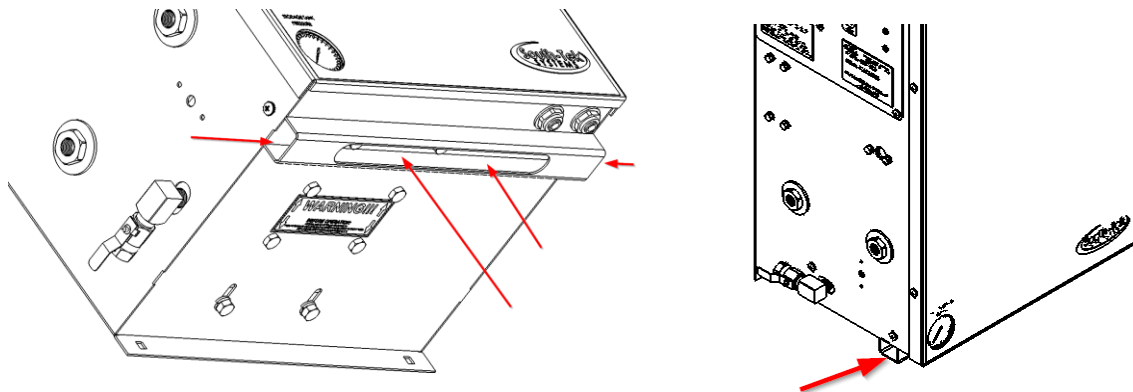

7 KEY CONTACTS

Contact your local provider/installer with any questions regarding the performance and/or maintenance of the system. They will be best suited to answer your questions and should be readily available to help provide a resolution to any issues you may have.

8 FAQs

8.1 POWER ISSUES

If the BeerBlast™ 1KPH / N2-GEN™ 1KPH does not have power, the production and storage of nitrogen will become apparent once the storage pressure drops. The taps will begin to pour slowly or not at all.

1. Check the power cord and power switch
2. Has the building's circuit breaker or GFCI tripped? Locate the breaker/device and reset. If the breaker continues to trip, the circuit may be overloaded.

8.2 PRESSURE ISSUES

If the gas blender is included, both gases (N₂ and CO₂) will need available pressures over 40 psig. Blenders will shut down output if either gas is not present over 40 psig.

The BeerBlast™ 1KPH / N2-GEN™ 1KPH will produce and store nitrogen between 60-80 psig. Once the storage tank reaches 70 psig, the system will go into Stand-By Mode. When the pressure drops to 60 psig, the system should go into Operation Mode and begin to refill the storage tank. If you are out of the specifications, we need to determine where the issue is. Contact the manufacturer or a factory trained technician.

CO₂ Pressure Check:

If you have the blender option, check the CO₂ regulator pressure gauge. It should read between 60 and 80 psig. If it is lower, check the CO₂ Storage tank to see if it needs refilling or if the pressure regulator needs adjustment. The pressure going into the BeerBlast™ 1KPH / N2-GEN™ 1KPH is recommended to be set at 80 psig.

Nitrogen Pressure Check:

Look at the pressure gauge on the top of the cabinet. It should be between 55 and 75 psig. If the pressure is low, a couple things need to be checked:

- Check the power.
- Check for leaks throughout the system. Refer to section on **Checking for Leaks**.

Pressure Regulation Check:

If the CO₂ and N₂ are both present and the blender is outputting gas, it is possible that a regulator is malfunctioning or needs adjustment. The mixed gas coming from the blender should be between 40-80 psig (dependent on the N₂ and CO₂ pressures going into the blender). A primary regulator is usually installed on the output lines coming from the BeerBlast™ 1KPH / N2-GEN™ 1KPH. The primary regulator is there to “step down” the available pressure to the kegs. There are typically secondary regulators located further downstream on the mixed gas lines going to the kegs. The secondary regulators are there to individually tune each keg. Some beers require more/less pressure and regulating each keg individually will allow the beer pouring to be optimized.

If the BeerBlast™ 1KPH / N2-GEN™ 1KPH is not operating correctly, then the establishment should contact their Draft Beer System Technician to adjust the regulators for optimal performance.

8.3 GAS LEAKS

As with any gas system, only use a spray bottle on non-electrical equipment to find leaks. Fix or replace leaking fittings or old hose. Push-to-connect fittings will show bubbles and typically have up to a 5ccm acceptable leakage rate. Contact your local provider/installer for help.

8.4 BLASTOFF™ - LEAK DETECTION SYSTEM (OPTIONAL FEATURE)

“There is an alarm sounding in the BeerBlast™ 1KPH / N2-GEN™ 1KPH and the control panel has a red BlastOff™ indicator light illuminated on the side of the unit.”



This means that it is equipped with the BlastOff™ - *Leak Detection System* feature. If the buzzer is on, there may be a leak in one of the gas lines, regulators, or one of the keg couplings may not be properly seated - causing gas leaks.

Note: Turn off this unit's on/off power switch and check for leaks. If none are found, leave the unit turned off and contact your Draft Beer System Technician. Once the leak has been fixed, turn the BeerBlast™ 1KPH / N2-GEN™ 1KPH on/off rocker switch “On” to resume normal operation. By turning the system power off, then back on, this will reset the BlastOff™ automatically.

APPENDIX A: WARRANTY

The BeerBlast™ 1KPH / N2-GEN™ 1KPH and N2-GEN™ 1KPH System is warranted against any defects in workmanship and materials for 12 months (or 1,000 hours) from the date of shipment from South-Tek Systems, whichever comes first. The purchaser has the liability to ensure that the system is fully inspected upon delivery and shall contact the appropriate shipping company to make any claims on damaged goods due to transit within that shipping company's policies. If the system is received with defects that are not due to shipping, a written claim should be submitted to South-Tek Systems within 1 week of receiving the shipment. South-Tek Systems can deny all other claims at their discretion.

All warranty work shall be done at a South-Tek System facility or at a BeerBlast™ 1KPH / N2-GEN™ 1KPH Authorized Service Center. Only factory trained and authorized personnel are covered under warranty. Any part that is returned / repaired / replaced under warranty may be remanufactured or changed to a different specification at the factory's option. Any work performed by an unauthorized person/company or usage of non-factory parts, may void all warranties to the product.

Any item not manufactured by South-Tek may carry its own warranty from its manufacturer and will be warranted by that manufacturer. All parts that need to be returned should be announced. Any item(s) that is returned to South-Tek Systems without an RMA number (return authorization number) may be denied and returned to the sender. Contact the factory for RMA #'s, prior to return shipment.

South-Tek Systems is not liable for damages caused by normal wear and tear, water, fire, erosion, corrosion, explosion, misuse, oil/gas vapors or unauthorized modifications. South-Tek Systems is also not liable for any losses (including CO₂), damages, or cost of delays, including incidental or consequential damages. There are no warranties or guarantees, expressed or implied, including the warranties of merchantability or fitness for a particular purpose or use, other than those warranties expressed herein.

For Claims, contact South-Tek Systems LLC at:

tel (910) 332-4173 or toll free (888) 526-6284, fax (919) 847-0255

Email: info@southteksystems.com

Or write to:

South-Tek Systems,

Warranty Claims,

2940 Orville Wright Way,

Wilmington,

NC

28405

-----Last Page-----