

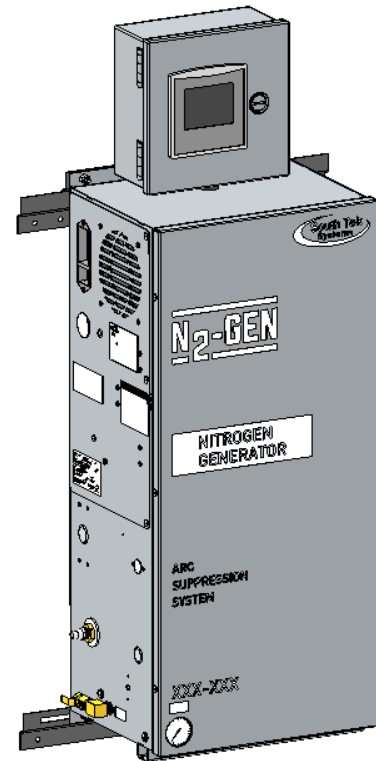

N2-GEN™ TL-450-PLUS & N2-GEN™ TL-1050-PLUS O&M MANUAL

Revision 0

Date 10/11/18

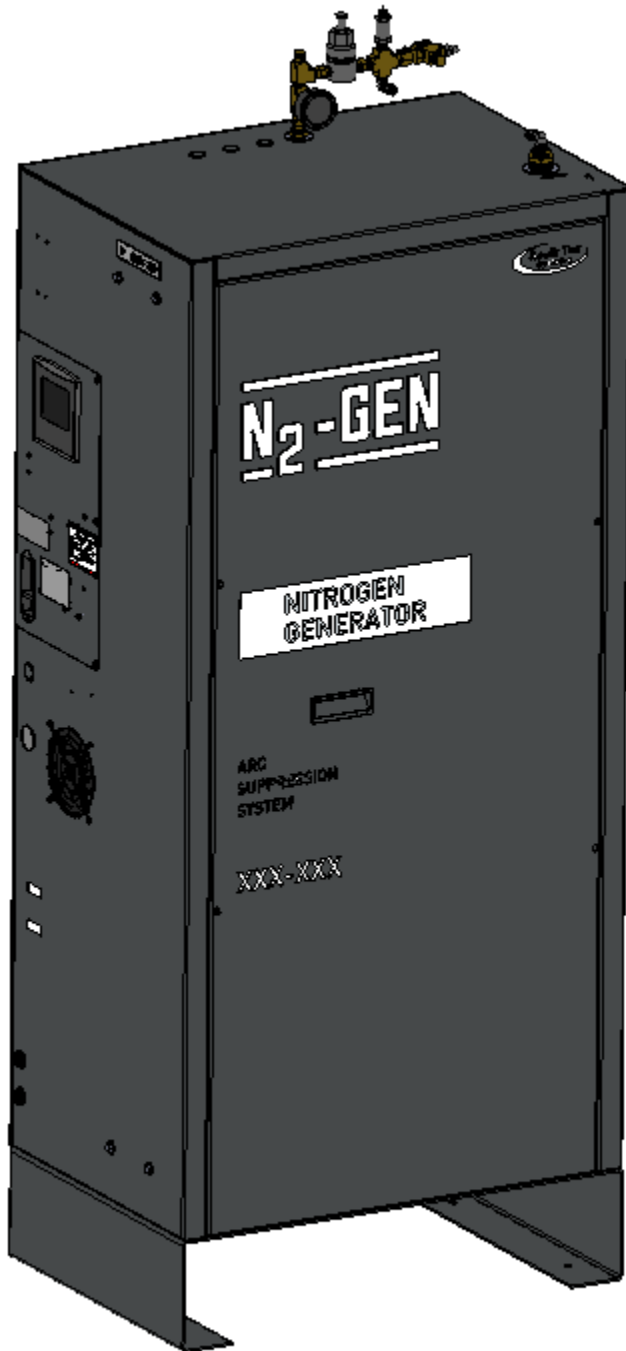

VERSION HISTORY

Revision #	Revised By	Revision Date	Approved By	Approval Date	Reason
0	K. Mellott	10/11/18	S. Andrews	10/18/18	New Product

TABLE OF CONTENTS

1	INTRODUCTION	6
1.1	Purpose.....	6
1.2	About South-Tek Systems.....	6
1.3	Audience.....	7
1.4	Limits of Liability	7
1.5	Service Return Policy	7
2	SAFETY GUIDELINES.....	8
2.1	General Safety Practices	8
2.2	Safety Information.....	8
3	RECEIVING, UNPACKING, AND STORAGE INSTRUCTIONS	9
3.1	Receiving Equipment.....	9
3.2	Unpacking and Preparation (N ₂ -GEN™ TL-450-Plus & N ₂ -GEN™ TL-1050-Plus).....	9
3.3	Storage Instructions.....	9
4	SITE AND UTILITY REQUIREMENTS	10
4.1	Air Supply	10
4.2	Additional Piping and Hosings.....	10
4.3	Electrical Requirements.....	10
4.4	Site Specifications	10
5	SYSTEM INSTALLATION.....	11
5.1	Mounting (N ₂ -GEN™ TL-450-Plus & N ₂ -GEN™ TL-1050-Plus).....	11
5.2	Installation (N ₂ -GEN™ TL-450-Plus).....	12
5.2.1	N ₂ -GEN™ TL-450-Plus General Arrangement.....	14
5.3	Installation (N ₂ -GEN™ TL-1050-Plus).....	15
5.3.1	N ₂ -GEN™ TL-1050-Plus General Arrangement	17
6	SYSTEM DESIGN	18
6.1	Specifications (N ₂ -GEN™ TL-450-Plus).....	18
6.2	Specifications (N ₂ -GEN™ TL-1050-Plus).....	18
6.3	Standard Features	19
6.4	Optional Features	20
7	SYSTEM CONTROLS AND COMMUNICATIONS	22
7.1	Home Screen.....	22
7.2	Powering On/Off	22
7.3	Starting/Stopping	22
7.4	System Run Hours.....	23
7.5	Trending Graphs.....	23
7.6	Menu Screen	24
7.7	Sensor Setup/Calibration.....	24
7.8	Alarms/Filter Parameters	26
7.9	Pressure Cut-In/Cut-Out Setup	28
7.10	Maintenance Menu	29
7.11	Information Screen	29
7.12	Logging Functionality (optional).....	29
7.13	Communication Settings for Ethernet Connection (optional)	30

7.14 Factory Settings **Error! Bookmark not defined.**

8 NITROGEN GENERATOR OPERATIONS 33

8.1 Start-up 33

8.1.1 Initial Start-Up 33

8.1.2 Normal Start-up 34

8.2 Shutdown 34

10 KEY CONTACTS 37

11 FAQs 37

11.1 Power Issues 37

11.2 Pressure Issues 37

11.3 Gas Leaks 37

11.4 General Issues 38

APPENDIX A: WARRANTY 39

-----Notes-----

1 INTRODUCTION

1.1 PURPOSE

South-Tek Systems welcomes you to the exciting world of nitrogen generators! We provide leading-edge technologies in **Pressure Swing Adsorption (PSA)** nitrogen generators that produce nitrogen on demand. The technology can reduce nitrogen gas costs by as much as 90% versus purchasing from a gas supplier. We develop PSA systems worldwide that are utilized in industrial, lab, restaurants, fire-protection, educational, and military facilities. We pride ourselves in our abilities to communicate and engineer nitrogen generation systems to meet specific requirements of our customers!

At South-Tek Systems, we engineer simple, turn-key generators to provide cost-effective means of producing nitrogen gas. The technology is based on years of continuous R&D on how to most effectively utilize carbon molecular sieve (CMS) to filter the nitrogen from oxygen in compressed air. We use the highest quality CMS provided to the market which goes through extensive in-house quality testing. Our design principles require clean, dry compressed air alternating through two adsorption pressure vessels packed with CMS. We have engineered our nitrogen generator with minimum maintenance and care requirements to provide our customers with years of confidence and reliability.

The N₂-GEN® provides an infinite supply of 98%+ pure Nitrogen, ensuring a constant -10° F to -40° F dew point within the transmission line. By freeing the environment of oxygen, moisture and contaminants, the N₂-GEN® maintains the integrity of the transmission line and prevents voltage arcing.

The N₂-GEN® was designed with minimal circuitry and moving parts, limiting failure points and maximizing life expectancy. Unlike a dehydrator, there is no need to constantly monitor, recharge, or replace desiccant material. With Pressure Swing Adsorption (PSA) technology, the N₂-GEN® requires only one quick and inexpensive filter change-out per year.

The two models discussed in this manual are the N₂-Gen® Arc Suppression System TL-450-Plus and the N₂-Gen® Arc Suppression System TL-1050-Plus.

**The installer and the user should read this manual in its entirety.

1.2 ABOUT SOUTH-TEK SYSTEMS

South-Tek Systems, founded in 1997, is a nitrogen generator manufacturer, designing and producing nitrogen generating systems for worldwide distribution.

Why not generate nitrogen at your own facility for a fraction of the cost versus endlessly paying for bulk liquid or delivered gas cylinders? We manufacture a full line of nitrogen generating equipment including:

- [The N2 GEN® Series](#) with generators ranging from the compact 1 LPM table top lab generator on up to the 50,000 SCFH unit
- [The BeerBlast™ Mixed Gas Dispense System](#) for restaurants and bars seeking the perfect draft pour
- [The TireBlast™ Nitrogen Tire Filling System](#) for automotive and tire shops seeking optimal tire pressure maintenance and fuel economy
- [The N2-Blast™ Corrosion Inhibiting Systems](#) for Fire Protection Industries seeking solutions to preventing corrosion within the piping system

With purities ranging from 95% up to 99.999%, we provide nitrogen generators that are sure to suit your needs. For more information about our complete nitrogen generator capabilities, please visit www.southteksystems.com.

1.3 AUDIENCE

This manual is intended for Installer/Equipment Operator/Supervisory Staff and should be read in its entirety prior to operation. Please contact South-Tek Systems for any operation and maintenance questions.

1.4 LIMITS OF LIABILITY

Buyer's exclusive remedy for all claims shall be for damages, and seller's total liability for any and all losses and damages arising out of any cause whatsoever including, without limitation, defects in build quality or defective performance of the system, (whether such claim be based in contract, negligence, strictly liability, other tort or otherwise) shall in no event exceed the purchase price of the system in respect of which such cause arises or, at seller's option, the repair or replacement of such; and in no event shall seller be liable for incidental, consequential or punitive damages resulting from any such cause.

Seller shall not be liable for, and Buyer assumes all liability for, the suitability and the results of using nitrogen by itself or in any manufacturing or other industrial process or procedure, all personal injury and property damages connected with the possession, operation, maintenance, other use or resale of the System. Transportation charges for the return of the System shall not be paid unless authorized in advance by Seller.

NOTE: Any **MODIFICATIONS** to the system or the system's configuration made by the customer without the written consent of South-Tek Systems will void the product's design specifications.

1.5 SERVICE RETURN POLICY

If the system cannot be repaired at the site, and it is necessary to return a system for service, the following procedures must be followed:

- The owner must obtain a written **Return Material Authorization** number, which references the model and serial number, from South-Tek Systems. No items will be accepted for service or credit unless prior written authorization has been issued by South-Tek Systems.
- All items are to be returned with the original packaging material if possible. Make sure that all items are packaged for safe return to South-Tek Systems. South-Tek Systems will not be responsible for damages, which occur in transit. Any damage that occurs to the system because of failure to adhere to this procedure will be the sole responsibility of the customer. Contact South-Tek Systems for a return shipping address.
- Shipping charges must be prepaid on all returns.

2 SAFETY GUIDELINES

The following section outlines the basic safety considerations regarding installation and operation of the nitrogen generator. For additional safety information regarding other equipment used in conjunction with the nitrogen generator, such as air compressors, dryers, boosters, etc., please refer to individual manufacturer recommendations and safety guidelines.

2.1 GENERAL SAFETY PRACTICES

Read carefully and act accordingly before installing, operating, or repairing the unit.

- Operator must use safe working practices and rules when operating the nitrogen generator.
- The owner is responsible for keeping the unit in safe operating condition at all times.
- Always use approved parts when performing maintenance and repairs. Make sure that replacement parts meet or exceed the original parts' specification.
- Only authorized, trained, and competent individuals can perform installation, operation, maintenance, and repair.
- Completely isolate incoming and outgoing pressures to the generator, and make sure to depressurize the service/repair section prior to performing any mechanical work, including changing the filters. The nitrogen generator's exhaust gas and/or any venting gas must be vented to the outside or to a large, well-ventilated room to avoid suffocation due to lack of oxygen.
- Safety glasses should be worn if the cabinet door is open while the machine is operating.
- Use ear protection when the equipment is operating.

WARNING: Pressurized gases are contained within the generator, the receiver, and product tanks. Pressurized gases are dangerous and may cause injury or death if handled or used inappropriately.

- Never allow pressurized gas to exhaust from an unsecured hose. An unsecured hose may exhibit a whipping action, which can cause serious injury. If a hose should burst during use, immediately close all isolation valves if it is safe to do so and power down the unit.
- Never disable or bypass any safety relief valves.
- Always make certain that the nitrogen generator is disconnected from the supply power prior to performing any electrical work.

NOTE: Always following local and site safety regulations in conjunction with this manual.

Correct use of the nitrogen generator is important for your personal safety. Incorrect safety practices can cause damage to yourself and/or to the equipment.

2.2 SAFETY INFORMATION

Nitrogen is not poisonous but it should not be directly inhaled, since in high concentrations, it can cause asphyxiation. Ensure that the unit is installed within a well-ventilated room, one that is not sealed off from normal living space air changes.

All personnel involved with installation, operations, and maintenance of the nitrogen generator must follow safe working practices, OSHA, and local health/safety code regulations during the installation, operation, and maintenance of the unit.

Warnings:

- This manual shall be read in its entirety before installing and operating the nitrogen generator to prevent accidents and damage.
- Contact South-Tek Systems if there is a problem that you cannot solve with this manual.
- Use the nitrogen generator in accordance with its designed purpose.
- Qualified personnel are permitted to perform installation, maintenance, and repairs. Work performed by unqualified persons shall result in a voided warranty.
- Do not tamper with, experiment on, or exceed the technical specifications of the equipment.

3 RECEIVING, UNPACKING, AND STORAGE INSTRUCTIONS

3.1 RECEIVING EQUIPMENT

The nitrogen generator and all components are securely packed to minimize possibilities of damages during shipment. The contents of the shipment should be inspected upon delivery to assure that no damage has taken place during transit. Save the packaging material, as it may be necessary to return the generator in event of shipping damage. If any components are found to be damaged, the carrier should be notified immediately. The individual pieces should be checked against the packing list. If any discrepancy is found, contact your local distributor or South-Tek Systems at (888) 526-6284. Please include the model number and the serial number with all correspondence.

3.2 UNPACKING AND PREPARATION (N₂-GEN™ TL-450-PLUS & N₂-GEN™ TL-1050-PLUS)

The N₂-GEN™ TL-450-Plus will be securely packaged in a cardboard container and the N₂-GEN™ TL-1050-Plus will be packaged in a wooden container. Open the container and inspect all parts for any damage upon receipt. Identify and verify that all parts listed on the packing list are present and undamaged. Any visual damages should be immediately documented (with photos) and immediately to the shipping company. South-Tek Systems (STS) is not responsible for damages that have occurred during the shipping and handling of the N₂-GEN™ TL-450-Plus & N₂-GEN™ TL-1050-Plus. Then, contact STS at (888)526-6284 to assess the damages only after the shipping company has been notified.

To remove the N₂-GEN™ TL-1050-Plus from the wooden crate, unbolt the cabinet base from the crate. Carefully, lift the unit from the crate and set it on the floor. The use of a pallet jack or forklift is advisable to move it to the final location. Once in place, unbolt the 4 colored bolts at the bottom of the cabinet.

The N₂-GEN™ TL-450-Plus is easiest to remove from its cardboard container by standing the box on end. Open the long side and slide the system out with its foam packaging material. Once in place, unbolt the 4 colored bolts at the bottom of the cabinet.

Until Installation:

- The N₂-GEN™ TL-450-Plus & N₂-GEN™ TL-1050-Plus can be stored inside the container until installation. For extended storage of over a month, open and insert desiccant bags as needed to prevent moisture buildup.
- Store the N₂-GEN™ TL-450-Plus & N₂-GEN™ TL-1050-Plus in a dry and climate controlled (60-80°F) room.
- Always keep the N₂-GEN™ TL-450-Plus & N₂-GEN™ TL-1050-Plus in an upright position.
- Do not connect power cable until this manual has been read completely and all connections are made as stated within.
- Keep all gas lines dry so you don't get moisture in the generator upon hookup.
- Never place/stack objects on top of the N₂-GEN™ TL-450-Plus & N₂-GEN™ TL-1050-Plus.

Store packaging container in a safe location in the case that it may need to be sent back to the factory for service.

3.3 STORAGE INSTRUCTIONS

If the unit is not to be installed until a later date, a safe dry storage location is needed, preferably inside a controlled environment. Place desiccant packets into the electrical cabinet to keep moisture from damaging the electronics. Do not store around moving objects that could fall or damage unit. If unit is kept in storage for an extended time (over 1 month), then the Oxygen Fuel Cell/Analyzer (if included) should be removed, taped off, and stored in a controlled environment.

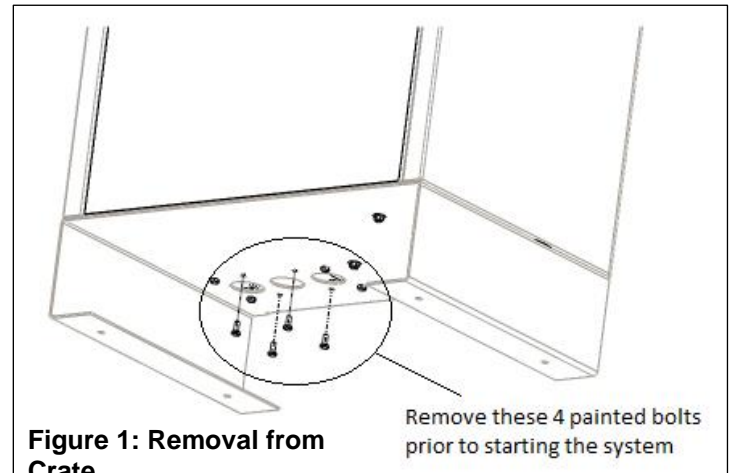

4 SITE AND UTILITY REQUIREMENTS

4.1 AIR SUPPLY

Ambient air around the generator must be between 40-100°F (4-38°C) with a relative humidity of 80% or better. Temperatures higher or lower than this may cause damage not covered under warranty. Moisture content higher than specified may damage the adsorbent material and void the warranty.

4.2 ADDITIONAL PIPING AND HOSINGS

The nitrogen feed piping components, supplied and installed by others, must be capable of supplying the required amount of feed nitrogen. If drains are to be installed on the nitrogen generator, ensure they are zero-loss drain lines.

4.3 ELECTRICAL REQUIREMENTS

The N₂-GEN™ TL-450-Plus & N₂-GEN™ TL-1050-Plus requires 110–220V / 50-60hz / 1ph connection. They have a built in 20A overcurrent protection device and a standard 3-prong US power cord is provided for the electrical connection (unless otherwise specified). The system has a UL 508A ICP approved certification. Electrical schematic available upon request.

4.4 SITE SPECIFICATIONS

Select a non-hazardous area indoors (unless the unit was specifically design for other areas) for installation which remains above 40 °F / 4°C and below 100 °F / 38 °C. Adequate space should be provided around the generator for access and routine maintenance. Ensure that there is enough space for the air receiver and product receiver skid next to the unit.

5 SYSTEM INSTALLATION

5.1 MOUNTING (N₂-GEN™ TL-450-PLUS & N₂-GEN™ TL-1050-PLUS)

The N₂-GEN™ TL-450-Plus can be mounted to a wall or secured on a floor whereas the N₂-GEN™ TL-1050-Plus can only be secured to the floor. It is recommended that the N₂-GEN™ TL-450-Plus be mounted to a weight-bearing wall that can support its weight. The N₂-GEN™ TL-1050-Plus should be fastened to a hard surface so it cannot move due to vibration or potentially fall over. The generator should always be installed indoors in an environment between 40° F and 100° F in the upright position where it will not be damaged by water or moving equipment. Leave at least 6" on the left side of the cabinet for ventilation, but 36" is recommended for access to the control panel, tube/pipe connections, and the front cover. At least 6" of clearance is recommended on all other sides of the cabinet except the back of wall-mounted units.

The optional mounting bracket kit (STS Part #: A05-TYP1-XX) allows the system to be mounted on a standard 16" wall stud width. Otherwise, use mounting holes on cabinet for mounting generator securely and level, directly to the wall.

Optional Mounting Bracket Kit for N₂-GEN™ TL-450-Plus Procedures

1. All mounting holes and optional mounting bracket holes are for ¼" screws/anchors.
2. All brackets must be installed in orientation as shown below.
3. Install the cabinet-mounting brackets on first with the bolts/lock nuts that are provided.
4. Install 18" bracket (with 16" center to center mounting holes and without the rectangular cutouts) on wall at the desired height. Use the 16" center to center holes to mount directly to the studs. Mount the bracket per diagram below using appropriate hardware (not included) for type of wall material (wood, sheet metal, masonry, etc....). Once installed, it will allow the 12" top bracket of the cabinet to hang on. See diagram as to how the angles are to be oriented on the back of the cabinet vs the wall.
 - a. Use the supplied nuts and bolts to attach the upper 12" bracket onto the top flange per the diagram.
 - b. Use the supplied carriage bolts and nuts to attach the 18" lower bracket to the bottom flange, do not completely tighten hardware yet. After installing the system, offset bracket slightly if repositioning is needed.
5. Optional: if wall studs are not 16" center to center or reinforcement to the mounting area is required, a ½" or thicker plywood can be installed prior to hanging the system. Use best general practices to ensure that the wood and system will be secure at its full weight and remember that it will be vibrating from compressor running.
6. Once the mounting brackets are all in place, hang the generator from the top bracket making sure it is centered.
 - a. The cabinet should have at least 4" on either side for venting purposes.
 - b. Do not install near heat source or where steam or water is present. Damage to system or bodily harm may result as well as voiding warranty.

Warning: Secure the N₂-GEN™ TL-450-Plus to the wall at the top and bottom flanges. Failure to do so could cause damage or bodily injury.

Item #	STS Part #	Description	Qty
1	TI-450-P™	Mini PSA	1
2	800-133	S-100/200 12" Mounting Bracket	1
3	800-134-B	S-100/200/400 18" Mounting	1
4	800-129	Type 1 Lower Wall Mount Bracket	1
5	Misc	0.250" -20 x 0.750" Carriage Bolt	2
6	Misc	0.250" -20 x 0.750" Hex Cap Screw	2
7	Misc	0.250" Nylock Nut	4
8	Misc	0.250" Flat Washer	2

Figure 2: Mounting Bracket Kit

Carriage Bolt must be installed from the back side of bracket

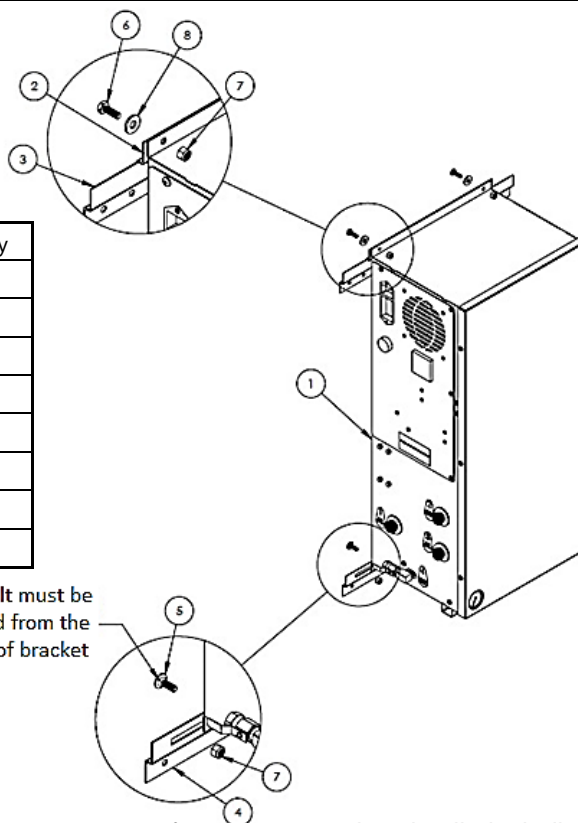

5.2 INSTALLATION (N₂-GEN™ TL-450-PLUS)

Refer to the General Arrangement drawing specific to your generator for gas connection details including location and fitting size. Double-check all connection are tighten before turning on the system or opening any valves. Check the connection fittings once the system is on and ensure no leak is present.

Once connections are all secure, turn on the power (switch is located externally on upper left side of cabinet's control panel). The initial start-up will require up to 1 hour to fully pressurize the internal storage tank to the correct level. External pressure gauge (in the bottom left of the front panel) can be viewed to verify that the internal storage tank has been filled to 65-75 psig. Once the tank is full, the system will automatically go into a standby mode and is ready for standard operation. If starting the system from 0 PSIG, a purge of the storage tank while maintaining pressure at 60 PSIG for 6 hours is recommended to exhaust any atmospheric gas that may have entered the system.

It is necessary to use caution when working with pressurized gas, making sure that all fittings and gas lines are installed correctly. Always leak check every line before using the system.

Note: Line leaks will cause the N₂-GEN™ TL-450-Plus to run excessively, shortening its life.

The N₂-GEN™ TL-450-Plus feeds a single nitrogen tank inlet. This line can be split after the output of the tank to provide the correct purity nitrogen to any equipment provided the nitrogen generator system is not overdrawn. Use only quality tubing and fittings for all connections. Keep in mind the temperature and pressure requirements when selecting them.

Always install a valve (on/off) on each individual line. This will help troubleshoot the system and maintenance. Never detach a line with pressure on it before closing the valve; this could cause damage to the equipment or bodily injury. Two condensate drains for the generator are located on the bottom right of the cabinet. It is the responsibility of the installer to plumb these drains to an area where water can be adequately dispersed or where a drain is located. Failure to do so can cause a slipping hazard on the floor below the generator.

If your system requirements are more involved, please consult with South-Tek Systems for a customized installation drawing.

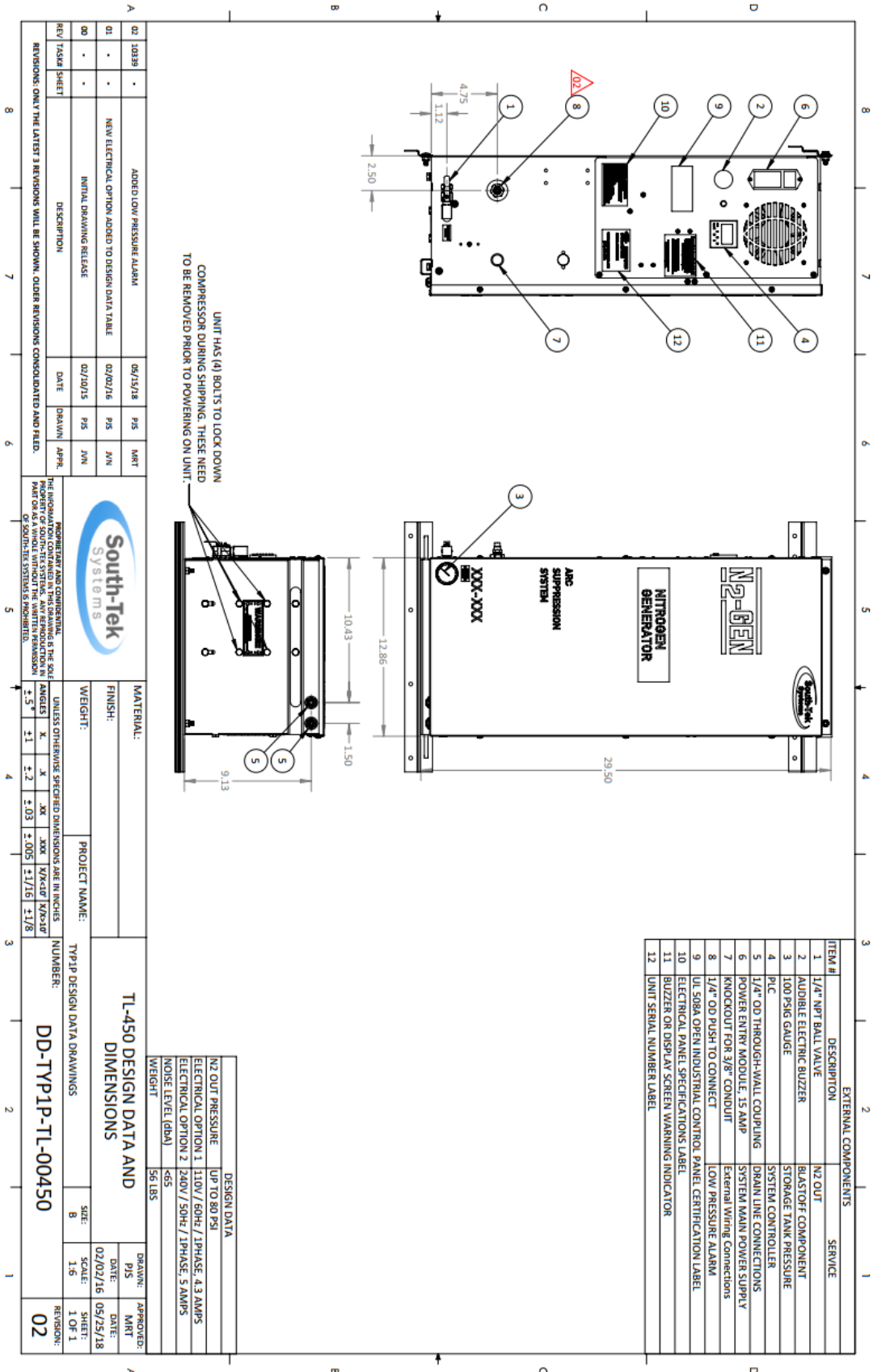

5.2.1 N₂-GEN™ TL-450-Plus General Arrangement

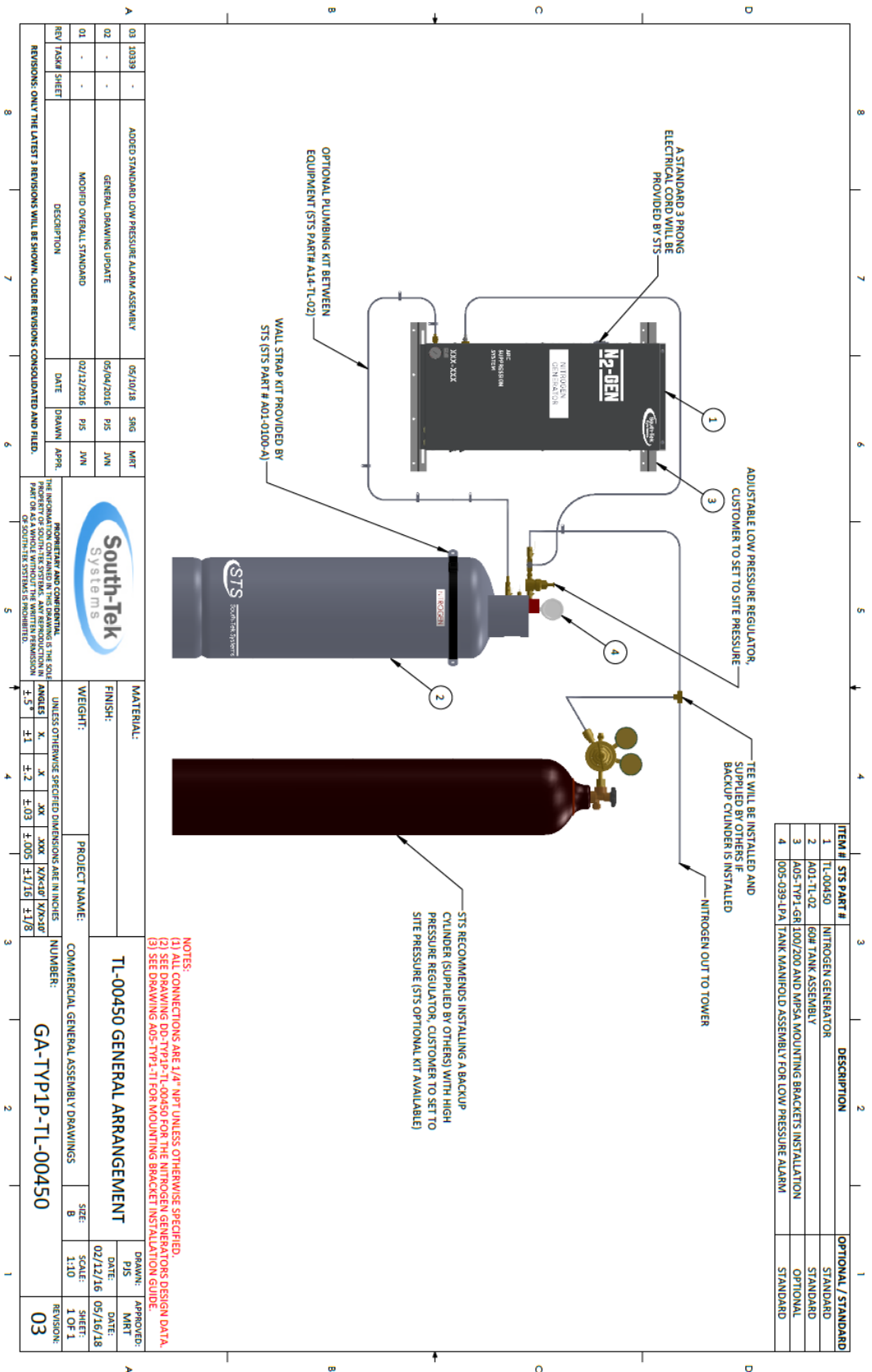

5.3 INSTALLATION (N₂-GEN™ TL-1050-PLUS)

The N₂-GEN™ TL-1050-Plus needs to be installed on a hard, flat surface capable of supporting 300+ lbs. There are (4) anchor bolt holes on the support legs that can be used to secure the unit to the floor. It is not required to be anchored, but always follow any site/local codes regarding securing equipment. The unit's back side and right side can be pushed all the way against the wall. Leave at least 6" on the left side of the cabinet for ventilation, but 36" is recommended for access to the control panel (otherwise, the unit will need to be pulled out to read the display. There are also two ¼" OD drain ports on the left side of the cabinet for the N₂-GEN™ TL-1050-Plus. These both can be plumbed to the nearest site drain. The front side of the cabinet requires 36" minimum to gain access to the front door and perform routine maintenance. Leave enough clearance room on the top of the cabinet for gas line connections.

First-time use will require an initial pressurization of the internal storage tank. To perform this task, make sure that all gas connections are properly made. All gas connection ports are ¼" NPT female.

Once the connections are all secure, turn on the power (switch is located externally on the upper left side of the cabinet on the control panel). The initial start-up will require up to 1 hour to fully pressurize the internal storage tank to the correct level. External pressure gauge (at the top coming off the 4th port from the left) can be viewed to verify that the internal storage tank has been filled to 65-75 psig. Once the tank is full, the system will automatically go into a standby mode and is ready for standard operation.

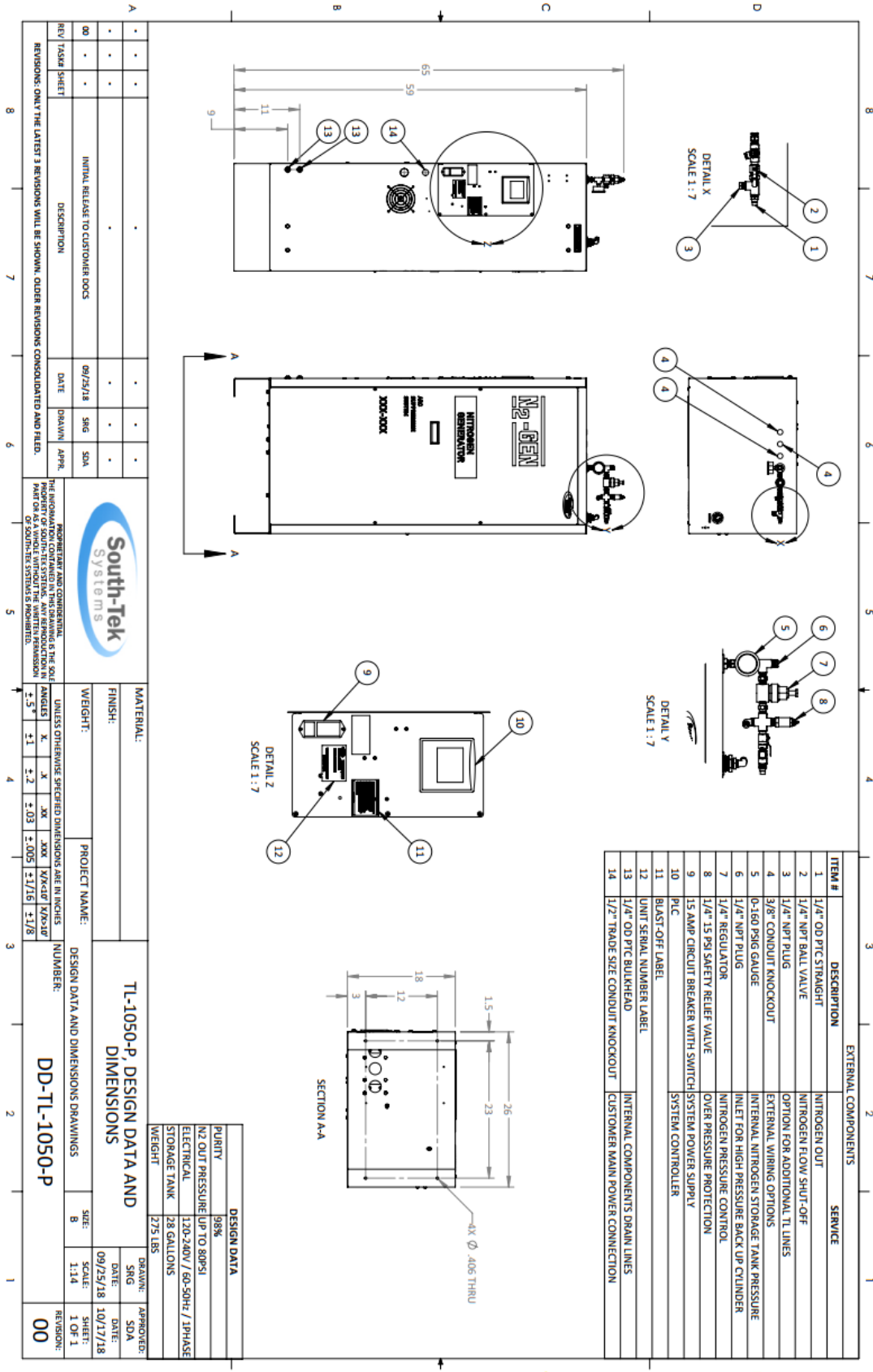

Revision: 0
 Revision Date: 10/11/18

5.3.1 N₂-GEN™ TL-1050-Plus General Arrangement

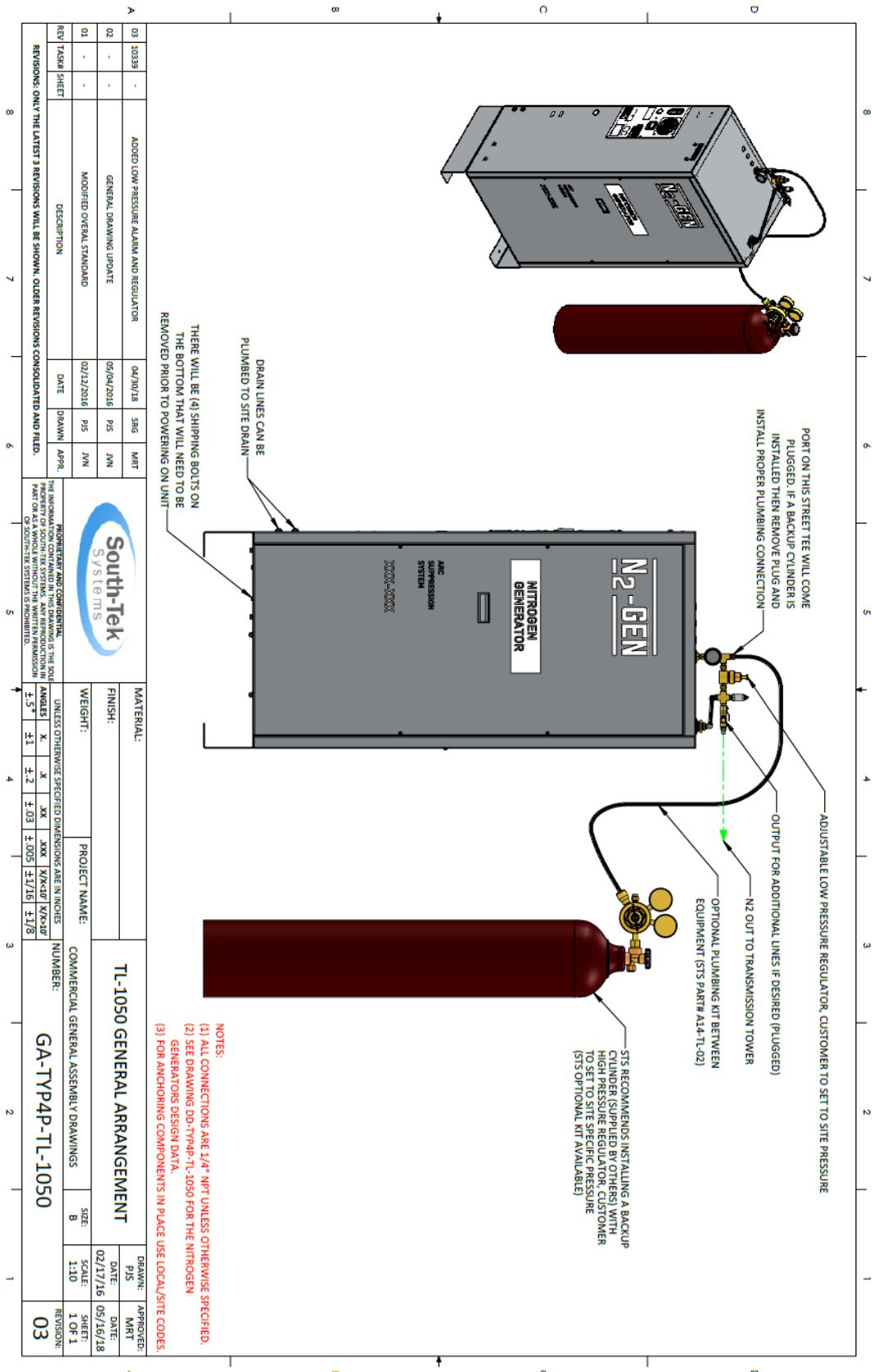

NOTES:
 (1) ALL CONNECTIONS ARE 1/4" NPT UNLESS OTHERWISE SPECIFIED.
 (2) SEE DRAWING DD-TYP4P-TL-1050 FOR THE NITROGEN GENERATORS DESIGN DATA.
 (3) FOR ANCHORING COMPONENTS IN PLACE USE LOCAL/SITE CODES.

6 SYSTEM DESIGN

6.1 SPECIFICATIONS (N₂-GEN™ TL-450-PLUS)

N ₂ -GEN™ TL-450-Plus – Specifications	
Nitrogen Purity	98%+ N ₂
Installation	Wall-Mounted
Display	Touchscreen HMI / System Status / Filter Schedule / Alarms
N ₂ Storage Pressure	60-70 PSIG
Cabinet Port Connections	1/4" OD Push-to-Connect
Electrical	110-220V / 50-60Hz / 1Phase; 20 Amp Breaker
Compressor	Integral / Oil-Free
Ambient Temperature	40° to 100°F
Noise Level (dbA)	< 70 dbA
Size	12.75" W x 12" D x 27" H (Cabinet Dimensions)
Weight	Appx. 100 lbs

6.2 SPECIFICATIONS (N₂-GEN™ TL-1050-PLUS)

N ₂ -GEN™ TL-1050-Plus – Specifications	
Nitrogen Purity	98%+ N ₂
Installation	Floor-Standing
Display	Touchscreen HMI / System Status / Filter Schedule / Alarms
N ₂ Storage Pressure	60-70 PSIG
Cabinet Port Connections	1/4" OD Push-to-Connect
Electrical	110-220V / 50-60Hz / 1Phase; 20 Amp Breaker
Compressor	Integral / Oil-Free
Ambient Temperature	40° to 100°F
Noise Level (dbA)	< 70 dbA
Size	26" W x 18" D x 59" H (Cabinet Dimensions)
Weight	Appx. 265 lbs

6.3 STANDARD FEATURES

The N₂-GEN™ TL-450-Plus & N₂-GEN™ TL-1050-Plus key features include the following:

- Air compressor
- Air Filters
- Pressure Swing Adsorption Beds
- Safety Relief Valves
- N₂ Storage Tank
- Automatic Pressure Cut-in/Cut-out
- HMI Touchscreen

Air Compressor:

The air compressor is designed internally to the cabinet and features engineered dampening system to reduce vibration and noise throughout the cabinet. It is an oil-less compressor with a pre-filter attached to the air input. The recommended replacement on the pre-filter is 1000 run hours or 1 year (whichever comes first). Dirtier environments may be required to be changed out more frequently. Consult your supplier for a different filter maintenance schedule if you are installing the generator in dirty environment.

Air Filters:

The generator has two filters after the air compressor: the particulate and coalescing. The Particulate has a 5-micron filter that will catch any of the larger particles. The Coalescing has a 0.1-micron filter that will catch the remaining smaller particles. Both filters feature and auto-drain that will drain the water captured after the air compressor. The drain is plumbed to the outside of the cabinet where the end-user can then connect ¼” tubing and drain to a safe location. An air intake filter can also be found in a metal housing mounted on the air compressor.

Safety Relief Valves:

Safety Relief Valves have been placed throughout the system for over-pressure protection. They are designed and put in place to minimize failure of other components. They all come with an ASME stamp.

N₂ Storage Tank:

A N₂ Storage Tank is housed inside the cabinet with manual ball valves and gauge. It is plumbed to an external manual ball valve so that the end-user will not have to do any plumbing within the cabinet.

Automatic Cut-In/Out:

The generator comes with a built-in pressure switch that is tied into the PLC. This will provide a low voltage signal back to the PLC to put the system in a “Standby Mode” when the tank is full of Nitrogen.

HMI Touchscreen:

There is an integrated PLC with a full color touchscreen. It features smart and efficient coding to maximize the performance. It controls the timing and sequencing of the valves to move compressed gas throughout the system. It is programmed to automatically come in and out of “standby” based on the storage tank pressure. A visual touchscreen is included which displays information such as run hours, alarms, sensor readings, and graphs of historical data.

Low Pressure Alarm:

The TL Series comes equipped with a low-pressure alarm that will provide an alarm contact for when the system is below a certain pressure (default factory setting = 1 PSIG). The alarm will reset when the pressure reaches 1 PSIG above the set point. This pressure switch is located inside the nitrogen generator cabinet.

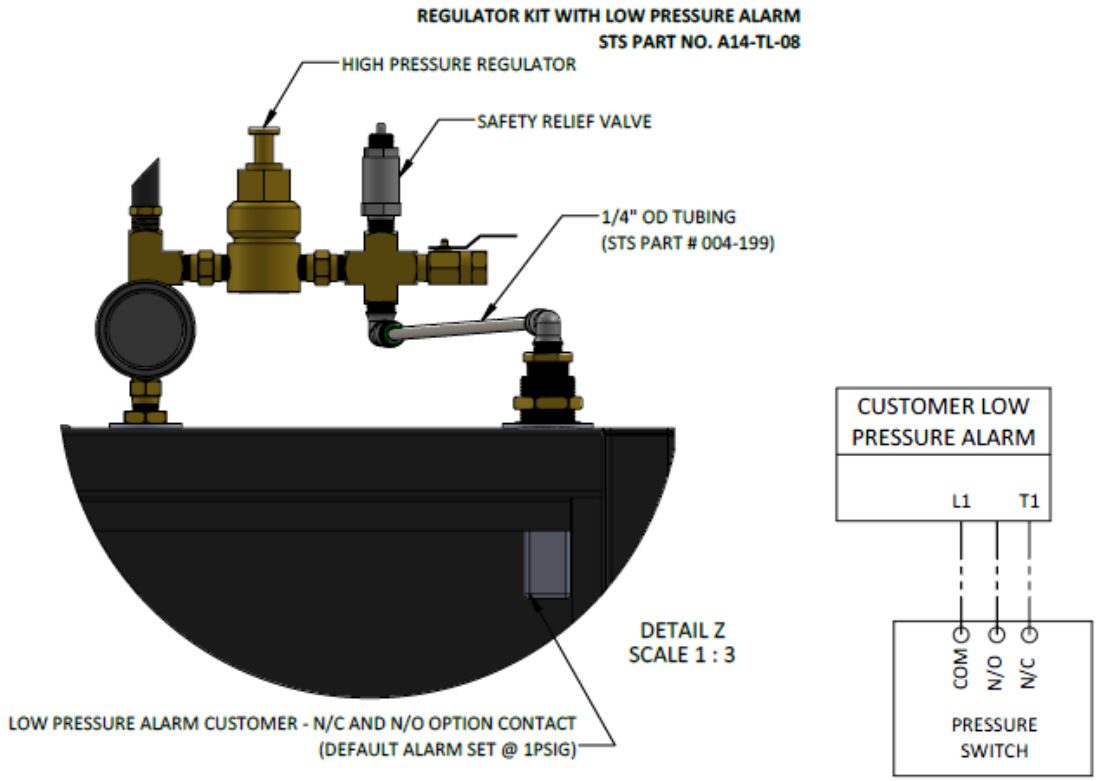

6.4 OPTIONAL FEATURES

Oxygen Analyzer:

An oxygen analyzer is an optional instrument that can be installed with the nitrogen generator to verify purity of the nitrogen in the storage tank.

For all units designed for 99.5% or lower, a galvanic cell type can be installed. The chemistry of the sensor is unique in that it implements a weak acid electrolyte and is unaffected by CO₂, CO, and NO_x. It has a response time of 25 seconds or less and will respond to a 90% step change in oxygen concentration within 15 seconds or better.

Both types of sensors are installed inside the cabinet enclosure and receive a small sample flow from the nitrogen storage tank to continuously monitor the nitrogen purity. Both sensors also have an output exhaust port that relieves excess pressure. It is important not to plug or restrict this flow; doing so will cause damage to the sensor.

The sample line for the N₂-GEN™ TL-1050-Plus models will come already connected to the O₂ sensor since the nitrogen tank is integrated in the cabinet with the nitrogen generator. For the N₂-GEN™ TL-450-Plus, a sample line from the nitrogen tank must be fed back to the analyzer via standard provided 1/4" OD push-to-connect tubing or customer provided hard piping. See the dash line (running to item #4) in the figures below for example of the O₂ sensor connection.

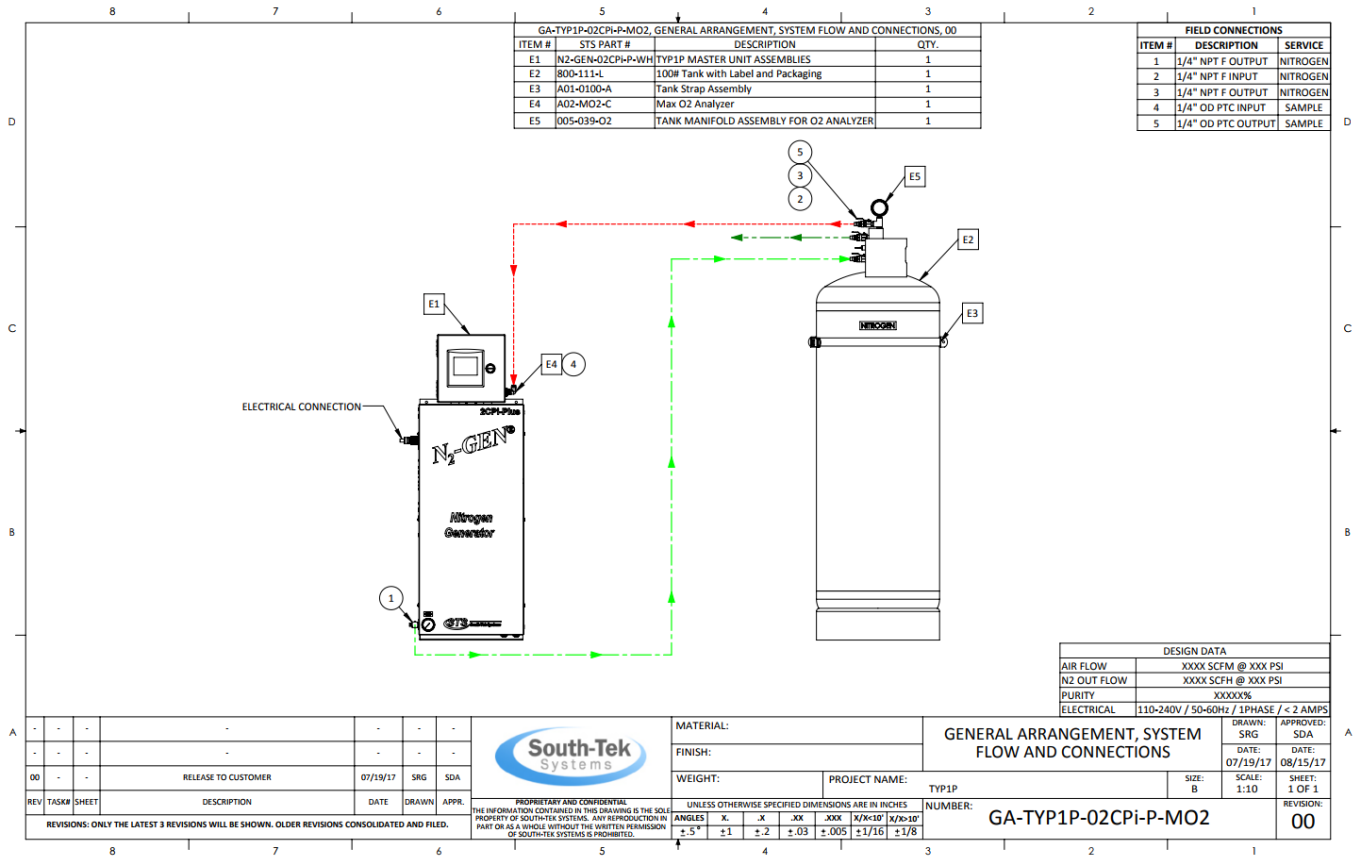

Figure 3: Sample line diagram for N₂-GEN™ TL-450-Plus

The O₂ sensor provides an analog signal that is sent to the PLC. It is then converted into a raw value on a bit scale and the reading is converted for display. Alarms can be set up via the touchscreen. The Zirconium Oxide oxygen sensor can have alarm set up via on the touchscreen or on the physical equipment.

7 SYSTEM CONTROLS AND COMMUNICATIONS

The nitrogen generator comes with controls and instrumentations uniquely programmed (proprietary to South-Tek) with a control sequence to effectively and efficiently generate high quality nitrogen on demand. It can be customized and engineered to meet specific needs. Any changes/customization must be performed/approved by South-Tek Systems or written approval must be obtained from South-Tek Systems. Unauthorized changes to the system will void all warranties and may cause damages to the system or cause it to malfunction.

This section describes the function of the major controls and instrumentations associated with the nitrogen generators. Do not attempt to alter any controls or instrumentations; any changes without South-Tek Systems' consent will void the performance specifications unique to the system.

The PLC is used for the control sequence of the valves and controls the nitrogen generator's functionality. All programs are proprietary and password-protected from the factory.

Note: Controls for supporting equipment, such as the compressor and dryer, are not included in this section. Please consult the original manufacturer's instructions for further information.

7.1 HOME SCREEN

The home screen displays relevant information regarding the nitrogen generator such as system status, purity set-point, nitrogen storage tank pressure/purity (if sensor option is included), and run hours. The user can manually start/stop and navigate to either the "Menu", "Graph" or "Alarms" (if any alarms are active) screens.

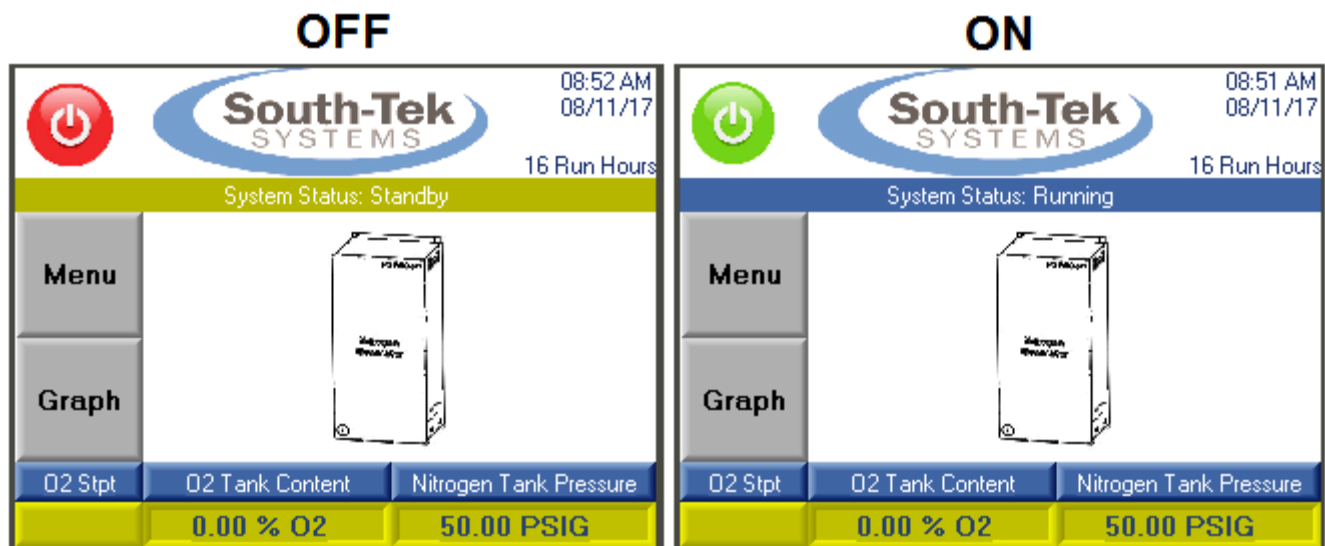

Figure 5: Home Screen

7.2 POWERING ON/OFF

Powering On/Off the unit can be done with the external power switch or other external disconnect, typically supplied by others.

7.3 STARTING/STOPPING

The nitrogen generator can be started and stopped on the controller touchscreen. The "Start/Stop" button is in the upper left corner. When illuminated green, the unit has been started and is considered "On". When illuminated red,

the unit is “Stopped” and considered “Off”. To change from the “On/Off” state, press the “Start/Stop” button and the switch will change colors indicating a mode change.

When the system is stopped, all valves will return to the normal position. It is recommended, to valve off the nitrogen storage tank outlet to the process so that the pressure levels in the tank do not fall below the cut-in pressure. Losing the tank pressure may cause the purity to fall out of specification for a brief period when the unit is restarted.

When the nitrogen generator is in the “On” state, it will automatically cycle through the adsorption beds to produce nitrogen to fill the storage tank. Once the storage tank reaches the cut-out pressure, it automatically goes into a “Standby” state, where it pauses the production of nitrogen. Once the storage tank pressure falls to the cut-in pressure, the system will automatically re-start and produce nitrogen to the tank again.

7.4 SYSTEM RUN HOURS

On the “Home Screen”, the system run hours is displayed in the upper right-hand corner below the current time and date. The run hours are calculated when the system is cycling and producing nitrogen. The “standby hours” are not included.

7.5 TRENDING GRAPHS

The “Graph” button on the “Home” screen will bring up historical trending data of the sensors included with the generator. Every generator will include a nitrogen storage pressure transducer; therefore, every unit will trend the tank pressure. Other optional graphing displays include oxygen purity, air flow, nitrogen flow, and incoming air pressure. Please contact South-Tek if other graphical displays are desired.

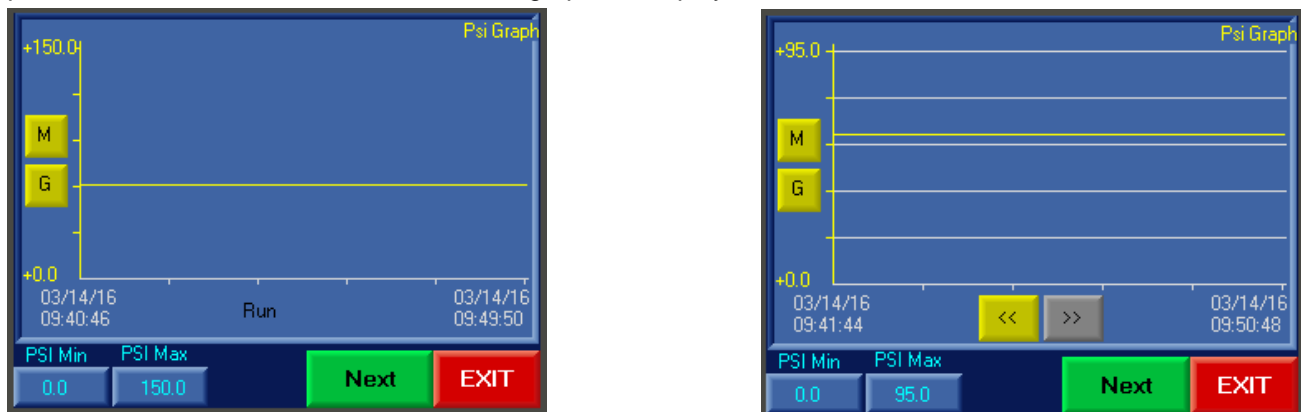

Figure 6: Left - Graph Screen, Right, Graph Screen with History Scroll and Grid Lines

The user can adjust the “Y-Axis” scale (pressure reading range) by adjusting the min and max values in the lower left corner of the screen. Press the box and a numerical keypad will appear. Enter in the desired values and press enter. The graph will automatically adjust once the min and max values are entered.

The “M” button can be toggled for scrolling back through the memory of the graph using the “<<” and “>>” buttons. The “G” button is to toggle horizontal gridlines to track trends. Press the “Next” button to go to the next graph, or press the “Exit” button to return to the home screen.

7.6 MENU SCREEN

The “Main Menu” screen (accessed from home screen), is password protected. Please consult the second page under “Revision History” of the provided hard-copy manual for the user password.



Figure 7: Main Menu Screen

Once access is granted to “Main Menu”, the user can access all but the “Factory Settings” options shown in the above figure.

7.7 SENSOR SETUP/CALIBRATION

The “Sensor Setup/Calibration” screen allows the user to calibrate sensors included with the nitrogen generator. Every unit will have a nitrogen storage pressure sensor and typically, the oxygen (O₂) sensor is recommended as an add-on. Other additional sensors that are available include incoming air temperature, incoming air pressure, incoming air flowmeter, incoming air pressure dewpoint meter, nitrogen out pressure dewpoint meter, and/or nitrogen out flowmeter.

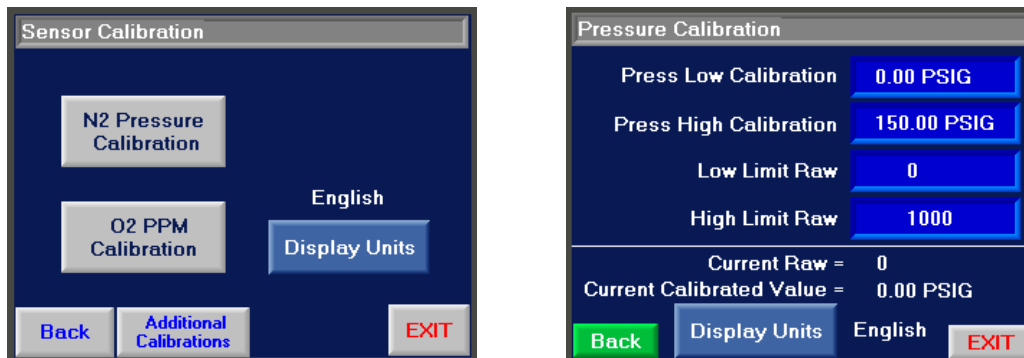

Figure 8: Left Screen - Sensor Calibration Selection, Right Screen - 2-Pt Calibration Values

All sensors are setup with a 2-point linear calibration. To setup the calibration, the user will need two known points. It is best to select two points at opposite ends of the sensor’s calibration range. The following charts is the recommended 2-Point Calibration range for the “Low” and “High” point.

Table 1: Recommended 2-Point Calibration Ranges

	Calibration Value Ranges	
	Low Point	High Point
Pressure	0-5 PSIG	100-150 PSIG
O ₂ %	0.5-1.5% O ₂	10-21% O ₂
O ₂ PPM	100 PPM	1000 PPM

The “Low Limit Raw” and “High Limit Raw” are determined by the “current raw” reading at the time the known calibration source is applied to the sensors. For example, when the known pressure is 0 PSIG to the pressure sensor,

read the “Current Raw” value and enter that in the box next to the “Low Limit Raw” text. Then apply a known pressure of 100 PSIG to the sensor and read the “Current Raw” value (which should be different – if not, the sensor or wiring connection may be bad) and enter that value in the box next to the “High Limit Raw” text.

Other notes for calibrating units with % O₂ sensors:

1. Make sure certified gas is being used for the low point.
2. Clean dry compressed air (20.9) can be used for the high point.
3. Make sure to only flow 1-2 scfh to the sensor. Higher flow may damage the sensor.
4. Never block the outlet purge line – it is a ¼” OD polyethylene tubing that extends 12-18” from the output of the sensor.

Other notes for calibrating units with 7100 Analyzers:

1. Syncing the 7100 analyzer screen reading to the Nitrogen Generator display can be done by the following method:

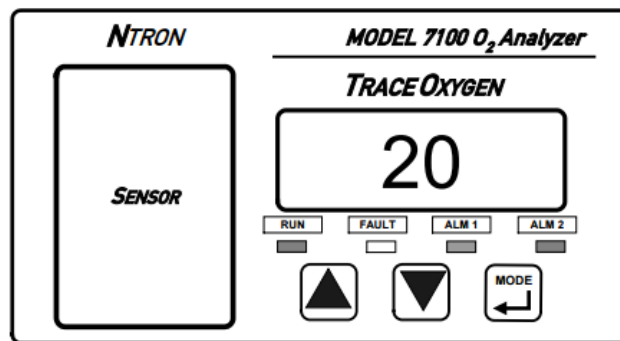

Figure 9: 7100 Analyzer Front Control Panel

- a. Press the mode button twice – should scroll through “Cal”, then “Alm 1” should appear.
 - b. Hold the “down arrow” button until it reads “100”.
 - c. Go back to the nitrogen generator display and navigate to the “O₂ PPM Calibration” screen and enter in “100” next to the “Low Calibration” text. Read the “Current Raw” value and enter that value next to the “Low Limit Raw” text.
 - d. Return to the 7100 analyzer and press the “up arrow” until it reads “1000”.
 - e. Return to the nitrogen generator display and navigate to the “O₂ PPM Calibration” screen and enter in “1000” next to the “High Calibration” text. Read the “Current Raw” value and enter that value next to the “High Limit Raw” text.
 - f. Return to the 7100 analyzer and adjust the “Alm 1” value, back to the original value or leave it at “1000” if no alarms are hooked up to the 7100-analyzer.
 - g. Press the menu button until “Run” is indicated on the 7100 Analyzer.
2. The 7100-analyzer may show an alarm or fault due the O₂ reading being outside the alarm range. Even when the analyzer is reset and the purity of the gas has reached lower than the alarm setpoint, it will maintain the alarm/fault status for up to 30 minutes. Therefore, ignore the fault and alarm status for the rest 30 minutes after a change has been made.

7.8 ALARMS/FILTER PARAMETERS

The “Alarms/Filter Parameters” menu displays the O2 alarms and low-pressure alarm setpoints. The box next to the “O2 High Level” and “Low N2 Tank Press” is the user alarm setpoint. The “O2 Alarm” is triggered when the current O2 purity reading is higher than the setpoint value, and the “Low N2 Tank Press” alarm is triggered when the current nitrogen tank pressure reading is below the setpoint value. These alarms can be disabled by toggling the “On/Off” button on the “Other Settings” screen. The local audible can be turned “On/Off” on the “Other Settings” screen as well.

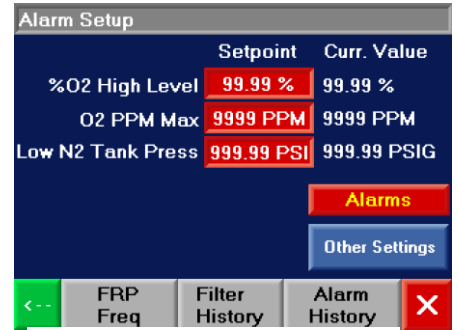

Figure 10: Alarm Setup Screen

Other Alarm Options (not all models will have all options below available):

If the system includes the “Low Purity System Purge” option, the user can activate it by going to the “Other Settings” screen. Press the button to “Yes” and enter in the delay time value (hours:mins, i.e. 00:05 is 5 minutes) next to it. The delay time value the amount of time that they system needs to be in spec prior to switching from “purge mode” to “process flow mode”. The warmup mode (Hours:minutes:seconds:milliseconds), is the amount of time to pre-purge the system upon manually restarting the system. It will only purge if the “Low Purity System Purge” is included with the package.

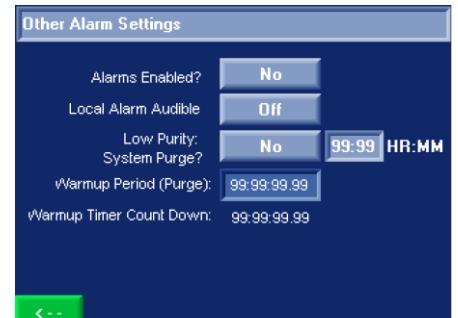

Figure 11: Other Alarm Settings

Alarm Status/History:

The red “Alarm” button (bottom right corner) will bring up a secondary “Alarm Status” screen. Here, the user can get a read out of the current alarm statuses. The user can get more information by going to “Filters Info”, “Alarm Details”, “Alarm History”, or “Clear History”.

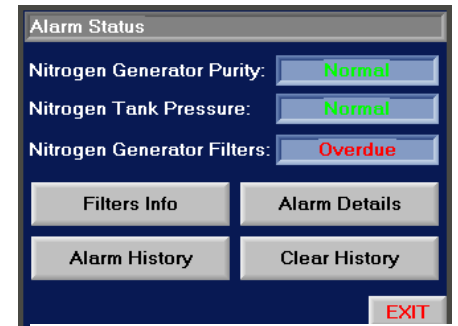

Figure 12: Alarm Status

Alarm Details:

The “Alarm Details” screen will allow the user to see a list of alarms and when the alarm was triggered (time and date).



Figure 13: Alarm Detail Screens (Button below "Details" Column Brings up the Next

Alarm

History/Clear Alarm History:

Pressing the “Alarm History” button will take you to the alarm history log. Here, the user can scroll through the history of alarms and see what alarm, when it was triggered, time, duration, and when it was deactivated. Up to 256 alarms can be stored. The user can clear the alarm history log pressing the “Clear History” button. It will bring up another screen requesting an entry of “1111” to confirm clearing the alarm history.

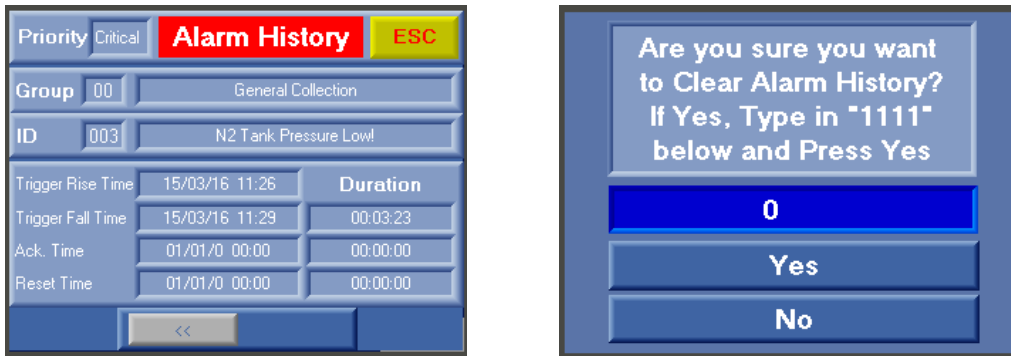

Figure 14: Alarm History Log (Left), Clear Alarm History Confirmation Screen (Right)

Filter Information Screens:

The "Filter Info" screen will display the current filter status of either "Good" or "Overdue". If "Overdue" is highlighted, it is advisable to change out the corresponding filter as soon as possible. Once changed out, the user can press the corresponding green filter element button to reset the filter calendar.



Figure 15: Filter Info Screen

The "FRP Freq" screen will display the factory recommended filter element replacement schedule. It will also display the status of each individual filter – "Ok" or "Overdue". The user can reset the filters by pressing the reset button.

Filter Element Replacement Schedule			
	Freq (Mo.)	Status	Push to Reset
Particulate	3 (mo)	Ok	
Coalescing	6 (mo)	Ok	
Absorber	12 (mo)	Ok	
Back	Filter History	EXIT	

Figure 16: "FRP Freq" - Filter Replacement Parts Frequency

The "Filter History" screen will display the last change dates of each individual filter element. The grey arrow button in the upper right will allow the user to manually enter in the last change dates if for some reason the filter change acknowledgement button was prematurely pressed.

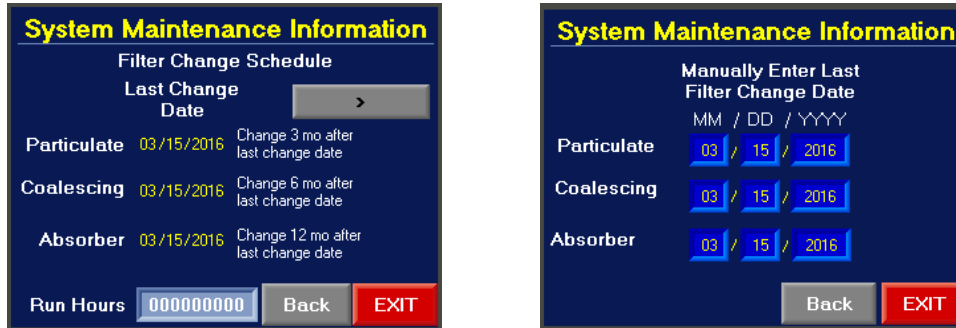

Figure 17: Element Last Change Date (Left), Manual Entry of Last Element Change Date (Right)

7.9 PRESSURE CUT-IN/CUT-OUT SETUP

The nitrogen generator is equipped with a pressure transducer to measure the nitrogen storage tank pressure. It is connected to the controller and the value is used to determine the cut-in and cut-out pressures, allowing the system to be more energy efficient. When the nitrogen storage tank reaches the cut-out pressure, the generator will go into a “standby” mode, where the delivery of air to the nitrogen generator will stop, and therefore, the production of nitrogen to the storage tank will also stop. The system will stay in standby until the nitrogen storage tank pressure falls to the cut-in pressure. The nitrogen generator will resume separating the oxygen from the compressed air and delivering nitrogen to the storage tank.

Note: The cut in / cut out settings are factory set and should not be adjusted without contacting South- Tek Systems. Adjusting the settings may alter the nitrogen purity and flow capabilities.

To see what the factory setpoints are, the user can press the “Menu” button from the main screen, then “Cut-in / Cut-out Parameters”.

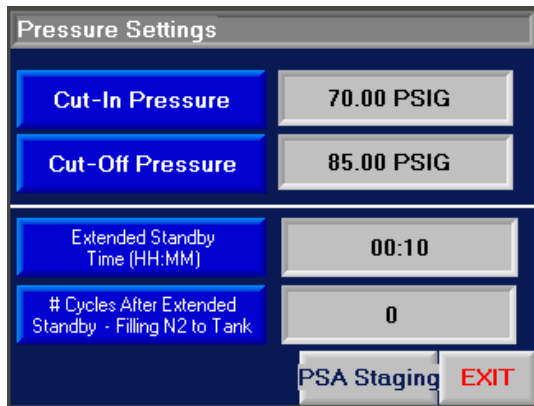

Figure 18: Pressure Setup Screen

7.10 MAINTENANCE MENU

The “Maintenance Menu” allows the user to individually toggle each valve to verify that they are working. It is recommended to have the unit in the “Stopped” mode and the nitrogen outlet valve (from the nitrogen generator) closed prior to toggling the valves individually. Make sure to reset the valves to “Off” prior to restarting the system.

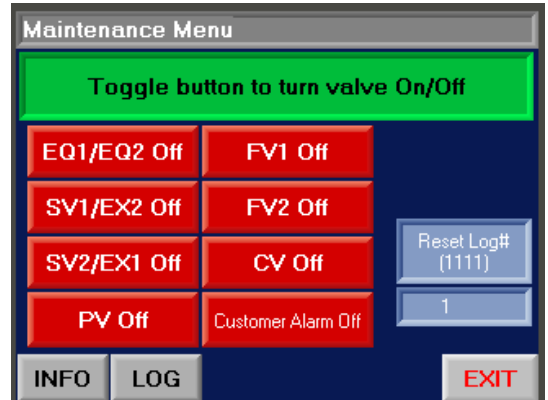

Figure 19: Maintenance Menu Screen

7.11 INFORMATION SCREEN

The “Information” screen will provide specific details such as current run hours, software version, manufacture build date, serial #, and date of commission. There is a short cut button to show the filter history too.

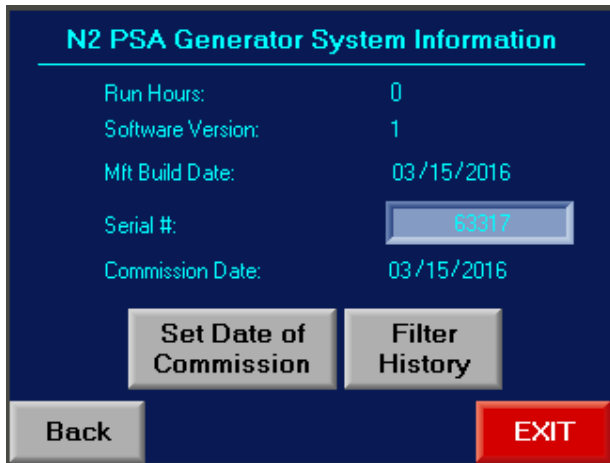

Figure 20: Information Screen

7.12 LOGGING FUNCTIONALITY (OPTIONAL)

Logging functionality (optional feature) allows user to collect the system’s data. To maximize the full logging capabilities, the system must be designed to have an air flowmeter, N2 flowmeter, O2 analyzer, nitrogen pressure (standard), incoming air pressure, and incoming air thermocouple. The table displays the current, average, max, and min values once the log is started (which can be started by pressing the “Press to **Start** Data Analysis” button located on the bottom left corner). Pressing the “Press to **Stop** Data Analysis” will pause the data collection, and then pressing the “Press to **Start** Data Analysis” will resume data collection. In order to restart the data collection with a fresh set of data, the user must press the “Reset Stats” button and then pressing the “Press to **Start** Data Analysis” button.



Figure 21: Data Logging Screen

Logging to SD Card:

To log the data to a Microsoft .CSV file (MS Excel file), a specially formatted South-Tek System’s micro SD card must be inserted into the controller. If the unit was purchased with the “Logging Functionality” option, the micro SD card will already be inserted to the controller (located on upper left side – looking at the back of the controller).

To start logging to SD card, do the following in the order listed:

1. Make sure the screen reads: “SD Card: OK” in the lower right corner of the screen.
2. Reset the Stats and Press “Press to Log to Excel”.
3. “Press to Start Data Analysis”, and the data will start recording to the SD card.

To stop logging and retrieve data, do the following in the order listed:

1. Press “Press to Stop Excel Logging”.
2. Press “Remove SD” card.
3. Wait for the green “Ready” message below the “Remove SD” button. If the message does not appear after 5 seconds, press it again.
4. Once the “Ready” message appears, remove the SD card from the back of the controller and insert it to a computer.
5. Open the computer drive that the SD card is on and open the folder.
6. To get to the file, navigate through the following folders: EXCEL > EXCEL1. Within the “EXCEL1” folder, find the file # to which the file was saved under (the file number is shown on the “Data Logging” screen).
7. Open the “Logging Header Template” also located under the “EXCEL1” folder and copy the column headers into the saved data log table.
8. Save the .CSV file with the copied column headers as a Microsoft Excel document to edit the document with personalized graphs.

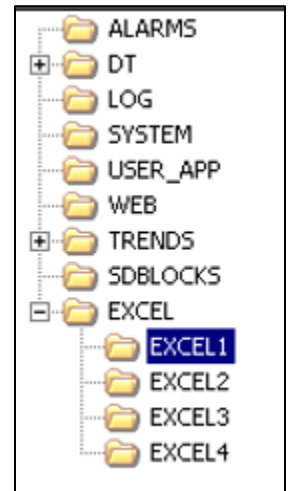

7.13 COMMUNICATION SETTINGS FOR ETHERNET CONNECTION (OPTIONAL)

If the optional Ethernet card is included with the nitrogen generator and the user wants to communicate with the system, a static IP address must be assigned to the controller. Once the static IP address is assigned, it must be manually entered into the controller. The subnet and gateway is not needed when accessing the controller within the organization’s intranet. Once the static IP is entered, the user must press the connect button or cycle the power to the controller to see the device on their intranet network. Communication through Ethernet includes Remote Access, SD Card Access, and MODBUS TCP/IP communication. A connection status message will indicate if a successful connection has been made.

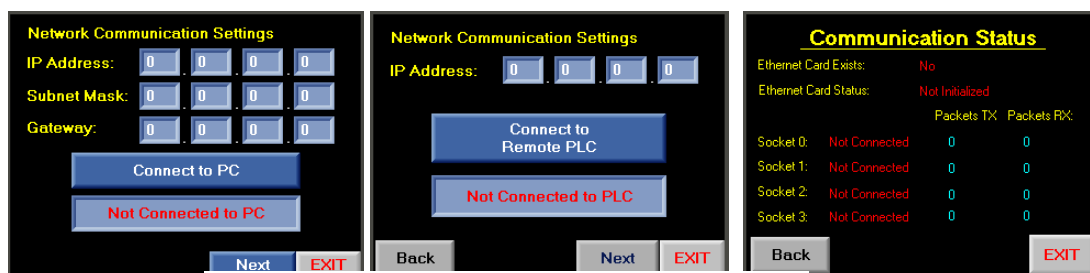

Figure 22: Network Connection Screens

Remote Access

A copy of the setup files for this software will be included on the microSD card installed in the PLC. This software can be installed on any Windows-based PC with Windows 7 or higher. The user will have full access of the controller touchscreen as if the user was standing in front of the machine and using the mouse to navigate through the screens. To set up communication connection to the controller, the communication settings on the computer must be set up to as the following:

1. Open the Remote Access Software and go to the “Configurations >Communication - PC settings”.
2. Select Connection Type: TCP/IP (Call)
3. Press the red folder to bring up the TCP/IP Addresses setup.
4. Enter static IP address assigned to the controller under “IP Address” column.
5. Select “TCP” under “Protocol” column.
6. Enter in the PLC Name (found on the 2nd page of the hard copy manual included with the Nitrogen Generator).
7. Press the “Get OPLC Information” to make sure the connection information is correct. An error message will appear if the information is not correct.
8. Press “Exit” once connection information has been confirmed.

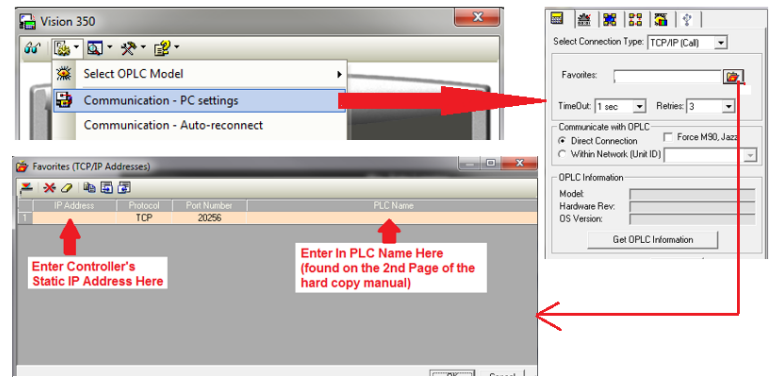

Figure 23: Remote Access Communication Setup

Loading Image File and Logging on

1. Open the Remote Access Software and go to the “Configurations > Select Fonts and Images file (*.urc)”.
2. Browse for the file “PLC Image File.urc” which is loaded onto the SD card.
3. Press the “Glasses” icon in the left corner of the software to establish real time connection with the controller.

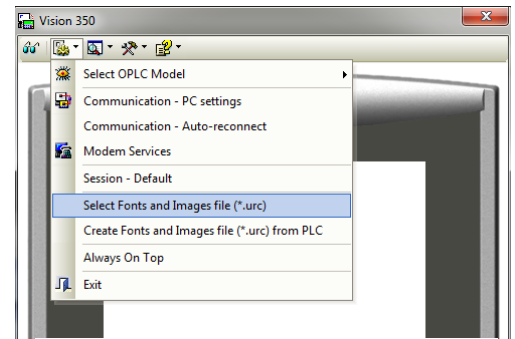

Figure 24: Loading Image File

SD Card Access

The setup SD Card Access file will also be included on the microSD card installed in the PLC. The SD Card Explorer software can be installed on any windows-based PC with Windows 7 or higher. This allows the user to have access of the files on the SD card without having to physically remove the SD card. Set up the communication similar to how the Remote Access is set up.

7.13.1 MODBUS Communication

Once the nitrogen generator is provided with a static IP addressed and can be seen on the network, MODBUS communication can be set up to retrieve real time data. The nitrogen generator MODBUS Communication settings are as follows:

- Protocol: TCP
- Local Port: 502
- PLC Controller: Slave

Coils		MODBUS Command Number	
Pointer Value From	Operand Type	Read	Write
0000	MB	#01 Read Coils	#15 Force Coils

Registers		MODBUS Command Number	
Pointer Value From	Operand Type	Read	Write
0000	MI (16 Bit)	#03 Read Coils	#16 Preset Holding Registers

See MODBUS addressing table below(all MODBUS addressing has an offset of 1):

Table 2: MODBUS Addressing Table

Registers (16 bit)	STS Controller (Unitronics)	Modbus RTU Address	Units/Status	Read/Write
Nitrogen Storage Pressure	MI 118	40119	XXX.XX PSIG	R
Oxygen Concentration (%)	MI 5	40006	XX.XX % O2	R
Generator Cut-In Pressure	MI 20	40021	XXX.XX PSIG	R/W
Generator Cut-Out Pressure	MI 21	40022	XXX.XX PSIG	R/W
Low Tank Pressure Alarm Point	MI 98	40099	XXX.XX PSIG	R/W
O2% Alarm Point	MI 14	40015	XXX.XX % O2	R/W
Registers (32 bit)				
Generator Total Run Hours	ML 14	28687	XXXXXXXXXX Hours	R

Coils				
Start / Stop	MB 12	00355	0=Off, 1=On	R/W
Running / Standby	MB 7	00008	0=Standby, 1=Running	R
Common Alarm	MB 61	00062	0=Good, 1=Alarm	R
Common Alarm Toggle	MB 19	00020	0=Off, 1=On	R/W
BlastOff Alarm	MB 2050	02051	0=Good, 1=Alarm	R
Oxygen Concentration Alarm	MB 0	00001	0=Good, 1=Alarm	R
Low Tank Pressure Alarm	MB 106	00107	0=Good, 1=Alarm	R
Particulate Filter Status	MB 14	00015	0=Good, 1=Change Needed	R
Coalescing Filter Status	MB 28	00029	0=Good, 1=Change Needed	R
Absorbing Filter Status	MB 29	00030	0=Good, 1=Change Needed	R
Low PLC Battery Indicator	SB 8	20489	0=Good, 1=Low Batt	R
Local Alarm Buzzer Toggle	MB 227	00228	0=Off, 1=On	R/W

8 NITROGEN GENERATOR OPERATIONS

This section describes the procedure for starting, running, and stopping the nitrogen generator. The operator should notify personnel in the area of the equipment start-up. Make sure the start-up will not interfere with other operations.

8.1 START-UP

This section describes the necessary steps of both the initial start-up and a normal routine start-up. If this is the first time the unit has been started, follow the Initial Start-up procedure.

8.1.1 Initial Start-Up

1. Verify that power connection is 110 V or 220 V / 1 PH / 50 - 60 Hz as labeled on the unit and that the touchscreen on the generator is in the "Stopped" mode (the "start/stop" button in the upper left corner of the "Home" screen – red button indicates that the system is in stopped mode).
2. Start-up air compressor following the original equipment manufacturer's instructions. Once it has been started up and the air receiver is fully pressurized to the air compressor design pressure, open the air valve to the generator.

NOTE: During the start-up sequence, check for leaks in all pipe-fittings and valves.

WARNING: Shut off air supply valve and depressurize the system before repairing any leaks.

3. Open the nitrogen supply out to the nitrogen storage tank and the gas sample valve from the tank to the generator. Keep the nitrogen out to process valve closed for now.
4. On the nitrogen generator controller, toggle the "Start/Stop" button so that it toggles to green, and the nitrogen generator should start cycling through valves and pressurizing.
5. Observe pressure gauges on the filter combo for 10 minutes and make sure that the pressure swings from bed to bed every 50-90 seconds. Either bed fully pressurized should reach within 3-5 PSIG of the other fully pressurized bed. While one bed is pressurizing, the other bed should be exhausting completely.
6. Nitrogen will start to flow to the nitrogen storage tank and should begin building pressure.
7. When the nitrogen storage pressure reaches the cut-out pressure, the system will go into "standby" mode, indicated on the "Home" screen and the nitrogen production will pause.
8. Now that the system is in "standby", open the nitrogen to process valve and the nitrogen storage tank will start losing pressure. Once the pressure falls to the "cut-in" pressure, the system will automatically restart and fill nitrogen into the storage tank again.

NOTE: When the nitrogen generator is turned on for the first time or after a prolonged shutdown period, some of the lines may have equalized and balanced the nitrogen and oxygen. Therefore, at the restart, the first few cycles of nitrogen being delivered to the storage tank may not be producing the design purity specification.

8.1.2 Normal Start-up

Follow this procedure to start the generator for normal operation. If this is the first time the unit has been started, follow the Initial Start-up procedure, 8.1.1.

1. Open the air isolation valve.
2. Toggle the “start/stop” button to “start” (button should be illuminated green to indicate that the system has started).
3. Open any shut off valves in the product Nitrogen line to the user’s piping system. Allow the system purity to rise before using product.

NOTE: If the generator or any part of the system has been opened to the atmosphere, the system must be purged of any residual air.

8.2 SHUTDOWN

In case of an emergency, simply turn off the main power switch to the nitrogen generator. This will stop all generator functions immediately. Nitrogen supply can be shut off manually closing the nitrogen to process valve located on the output of the nitrogen storage tank.

For normal shutdown, valve off the nitrogen to process valve on the output of the nitrogen storage tank. Then, toggle the “Start/Stop” button to off on the “Home” screen.

WARNING: The generator will remain pressurized after shutting it down. Before performing any maintenance or opening any piping systems, always depressurize the system. Failure to do so may result in injuries.

9 SYSTEM MAINTENANCE

Whenever performing any maintenance on the system, make sure to power off the system. Remove the front cover to gain access to the filters.

Annual Filter replacement kit part # FRP-007

Air Intake Filter

The integrated air compressor has an air intake pre-filter. It is designed to prevent particles from entering the compressor housing and damaging internal components. This filter needs to be replaced once per year or every 1000 hours, whichever comes first. To do so, remove the pre-compressor filter cap by twisting it clockwise. Remove the old element and use a clean dry cloth to clean the filter bowl before installing the new element in reverse order.

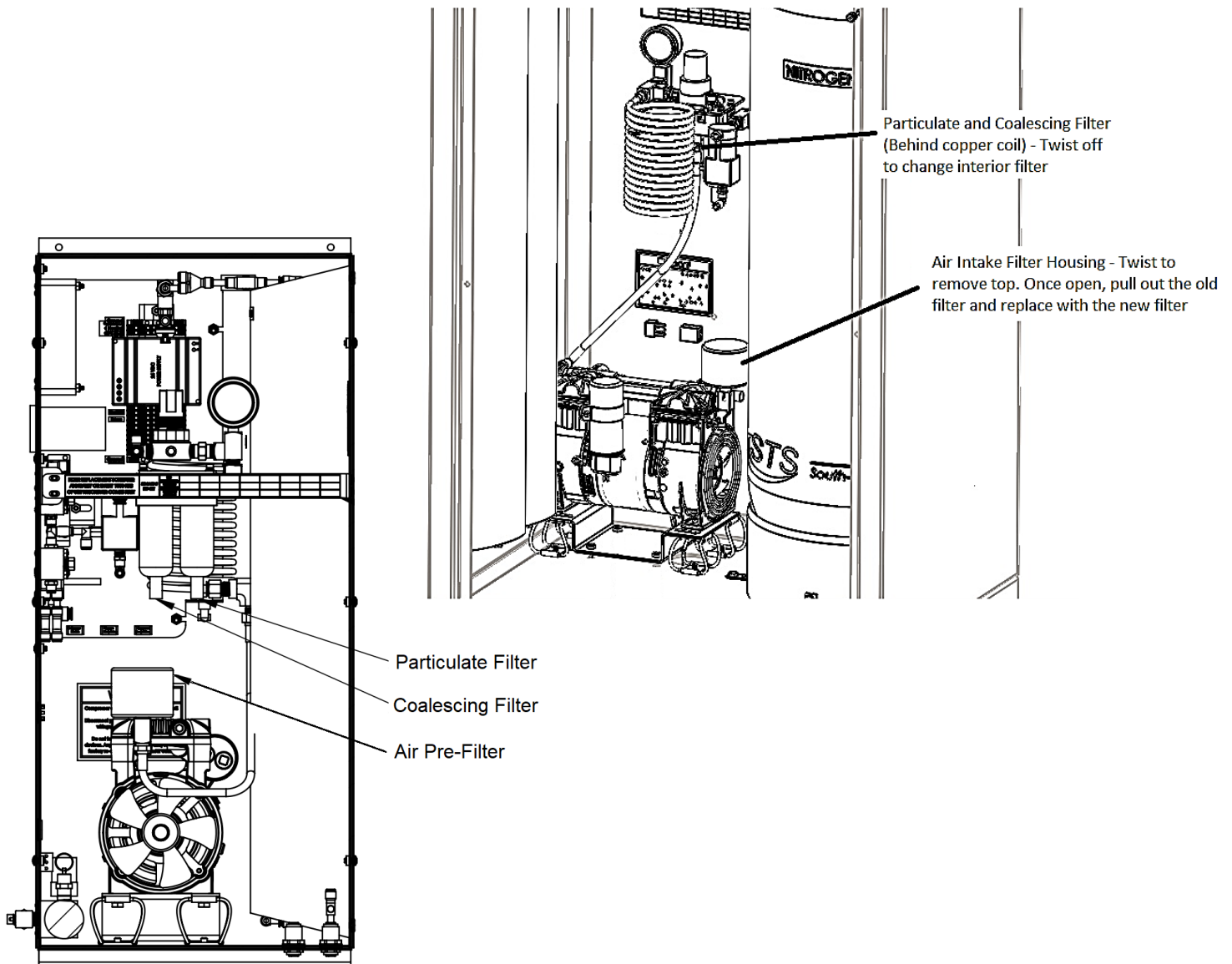

Particulate and Coalescing Filter

The particulate and coalescing filter after the air compressor captures particulate and moisture prior to entering the rest of the system. These filters need to be replaced once per year or every 1000 hours, whichever comes first. To do so,

1. Make sure there is no pressure on the filter bowls. The gauge after the filter bowl will read 0 PSIG to indicate that there is no pressure on the bowl.
2. Unscrew the filter bowls by turning them counter clockwise.
3. Once the filter bowls have been removed, rinse any debris out of the bowls with warm water.
4. Dry the bowls with a clean dry cloth and replace the old O-rings with the ones provided in the kit.
5. Pull the black plastic element housing out of the particulate filter bowl, remove the white particulate element and replace.
6. The coalescing element can be removed by turning it counter-clockwise with your hand; then replaced with the new element in the reverse order.
7. Once both elements and O-rings have been replaced and bowls have been cleaned, the bowls can be screwed back in to their corresponding filter housings.

Once all the filters have been replaced, reset the filter element scheduling according to **7.8**. Put the front cover back on the cabinet and the unit can be powered up again. Once powered up, you should hear the air compressor turn on and the N₂-GEN™ TL-450-Plus & N₂-GEN™ TL-1050-Plus will be producing nitrogen. Be sure to check the filter bowls for leaks.

10 KEY CONTACTS

For any questions with the performance and/or maintenance of the system, contact:

South-Tek Systems

2940 Orville Wright Way, Wilmington, NC 28409

Phone: 1-(888)-526-6284

Email: info@southteksystems.com

Visit: www.southteksystems.com

11 FAQs

11.1 POWER ISSUES

If the N₂-GEN™ TL-450-Plus & N₂-GEN™ TL-1050-Plus does not have power, the production and storage of nitrogen will become apparent once the storage pressure drops. The taps will begin to pour slowly or not at all.

1. Check the power cord
2. Has the building's circuit breaker or GFCI tripped? Locate the breaker and reset. If the breaker continues to trip, you may have that circuit overloaded.

11.2 PRESSURE ISSUES

The N₂-GEN™ TL-450-Plus & N₂-GEN™ TL-1050-Plus will produce and store nitrogen at 70 (+/-3) psig. Once the storage tank reaches 70 (+/-3) psig, the system will go into Stand-By Mode. When the pressure drops by about 7-10 psig, the system should go into Operation Mode and begin to refill the storage. If you are out of the specifications, we need to determine where the issue is. Contact the manufacturer or factory trained technician.

Nitrogen Pressure Check:

Look at the pressure gauge on the top of the cabinet. It should be between 50 and 80 psig. If the pressure is low, a few things need to be checked.

- Check the power.
- Check for leaks throughout the system. Refer to section on Error! Reference source not found..

Pressure Regulation Check:

Lastly, if the CO₂ and N₂ are both present and the blender is outputting gas, it's possible a regulator is malfunctioning or needs adjustment. The mixed gas coming from the blender should be between 40-80 psig (dependent on the N₂ and CO₂ pressures going into the blender). A primary regulator is usually installed on the output lines coming from the N₂-GEN™ TL-450-Plus & N₂-GEN™ TL-1050-Plus. The primary regulator is there to "step down" the available pressure. There are typically secondary regulators located further downstream on the mixed gas lines. The secondary regulators are there to individually tune.

11.3 GAS LEAKS

As with any gas system, only use a spray bottle on non-electrical equipment to find leaks. Fix or replace leaking fittings or old hose. Push-to-connect fittings will show bubbles and typically have up to a 5ccm acceptable leakage rate. Contact your local provider/installer for help.

11.4 GENERAL ISSUES

Symptoms	Probable Cause	Corrective Action
Nitrogen Generator Not Cycling	Low Voltage/Amperage	Check Electrical Source
	Circuit breaker tripped	Reset circuit breaker
	Fuse Blown	Replace fuses on electrical panel
	System is OFF (Left button on Home screen is Red)	Touch the Red switch for 2 seconds until it turns green
	Low Operator Air Pressure	Check incoming air source and/or internal air pressure regulator
	Defective Wiring	Check all wiring connections
Nitrogen Generator Running Continuously	Incorrect Cut-Out pressure	Set cutout pressure to factory setting
	Defective wiring with pressure transducer to the Touchscreen	Check the wiring connections
	Excessive N ₂ Leakage	Correct all N ₂ leakage
	Cycle Pressure too low	Check incoming air source and/or internal air pressure regulator
Low N ₂ purity	Product flow too high	Decrease product flow
	O ₂ analyzer malfunction	Replace O ₂ analyzer
	O ₂ flow port valved off	Open the O ₂ sample port
	Exhaust port plugged	Check exhaust tube is not blocked
Not building any storage pressure	Bad Process valve	Check each individual valve is working properly.
	Defective wiring	Check all wiring
	Disconnected pneumatic line	Check all pneumatic lines for leakage
	No Air Pressure going to the pilot valves	Make sure the pilot valves are getting adequate pressure

APPENDIX A: WARRANTY

The PSA Nitrogen Generator System is warranted against any defects in workmanship and materials for 24 months from the date of shipment from South-Tek Systems. The purchaser has the liability to ensure that the system is fully inspected upon delivery and shall contact the appropriate shipping company to make any claims on damaged goods due to transit within that shipping company's policies. If the system is received with defects that are not due to shipping, a written claim should be submitted to South-Tek Systems within 1 week of receiving the shipment. South-Tek Systems can deny all other claims at their discretion.

All warranty work shall be done at a South-Tek System facility or at a PSA Nitrogen Generator Authorized Service Center. Only factory-trained and authorized personnel are covered under warranty. Any part that is returned / repaired / replaced under warranty may be remanufactured or changed to a different specification at the factory's option. Any work performed by an unauthorized person/company or usage of non-factory parts, may void all warranties to the product.

Any item not manufactured by South-Tek may carry its own warranty from its manufacturer and will be warranted by that manufacturer. All parts that need to be returned should be announced. Any item(s) that is returned to South-Tek Systems without an RMA number (return authorization number) may be denied and returned to the sender. Contact the factory for RMA #'s, prior to return shipment.

South-Tek Systems is not liable for damages caused by normal wear and tear, water, fire, erosion, corrosion, explosion, misuse, oil/gas vapors or unauthorized modifications. South-Tek Systems is also not liable for any losses, damages, or cost of delays, including incidental or consequential damages. There are no warranties or guarantees, expressed or implied, including the warranties of merchantability or fitness for a particular purpose or use, other than those warranties expressed herein.

For claims, contact South-Tek Systems LLC at:

Tel: 1-(888)-526-6284

Email: service@southteksystems.com

Or write to:

South-Tek Systems, Warranty Claims, 2940 Orville Wright Way, Wilmington, NC, 28405

-----Last Page-----