

Code
9828093582-G-ST 00
Edit. 11/2021

INSTRUCTION AND MAINTENANCE MANUAL

DRYERS

10N – 15N – 20N – 30N

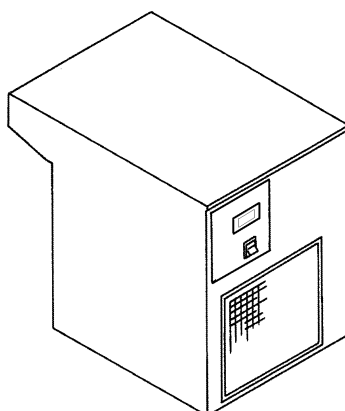

READ THIS MANUAL CAREFULLY BEFORE CARRYING OUT ANY OPERATIONS ON THE DRYER.

CONTENTS

PART A: INFORMATION FOR THE USER

- 1.0 GENERAL CHARACTERISTICS
- 2.0 INTENDED USE
- 3.0 OPERATION
- 4.0 GENERAL SAFETY STANDARDS
- 5.0 DESCRIPTION WARNING SYMBOLS
- 6.0 DANGER ZONES
- 7.0 SAFETY DEVICES

- 8.0 POSITION OF LABELS
- 9.0 INSTALLATION LOCATION
- 10.0 TRANSPORT AND HANDLING

- 11.0 UNPACKING
- 12.0 INSTALLATION
- 13.0 DIMENSIONS AND TECHNICAL DATA
- 14.0 MACHINE ILLUSTRATION
- 15.0 DISPOSING OF THE DRYERS

PART B: INFORMATION RESERVED FOR TECHNICALLY SKILLED PERSONNEL

- 16.0 PARTIAL ROUTINE MAINTENANCE
- 17.0 TROUBLE-SHOOTING AND EMERGENCY REMEDIES
- 18.0 STARTING UP

ATTENTION: THERE IS A COPY OF THE WIRING DIAGRAM INCLUDES WITH THE UNIT

ADDRESSES OF ASSISTANCE CENTRES

In the event of breakdown or malfunction of the dryer, switch it off and do not tamper with it. If repairs are needed, contact your dealer or the manufacture for an approved service contact and insist on the use of original spare parts. Failure to comply with the above may impact the safety and operation of the machine.

INTRODUCTION

Keep this manual for future consultation; the use and maintenance manual is an integral part on the dryer. Read this manual carefully before carrying out any operations on the dryer.

The installation of the dryer and all operations involving it must be performed in conformity with the regulations in force concerning electric plants and personal safety.

CHARACTERISTICS AND SAFETY PRECAUTIONS



**BEFORE REMOVING THE PROTECTIVE GUARDS TO CARRY OUT ANY MAINTENANCE ON THE MACHINE, SWITCH OFF THE ELECTRIC POWER SUPPLY AND DISCHARGE THE RESIDUAL PRESSURE INSIDE THE UNIT.
ALL WORK ON THE ELECTRONICS AND REFRIGERANT CIRCUIT, HOWEVER SLIGHT, MUST BE CARRIED OUT BY PROFESSIONALLY LICENSED PERSONNEL.**

The manufacturer does not accept responsibility for damage caused as a result of negligence of failure to abide by the instructions given above.

THIS MACHINE IS NOT SUITABLE FOR OUTDOOR INSTALLATION

THIS MACHINE CORRESPONDS TO THE ESSENTIAL SAFETY REQUIREMENTS FORESEEN FROM THE EUROPEAN STANDARD 2006/42.

THE LUBRICATING LIQUIDS AND OTHER CONDENSATE FLUIDS MUST NOT BE DISCHARGED IN THE ENVIRONMENT. THESE POLLUTING AND HAZARDOUS PRODUCTS MUST COMPULSORY BE DISPOSED OF ACCORDING TO THE LOCAL RULES AND REGULATIONS IN THE LOCATION OF THE INSTALLATION.

1.0 GENERAL CHARACTERISTICS

The dryer is a chilling machine with direct expansion heat exchanger and dry evaporator.

The air to be dried is sent to the heat exchanger where the water vapour present is condensed: the condensate gathers in the separator and is discharged outside through an electronic level sensing drain.

2.0 INTENDED USE

The dryer has been designed and built to dry compressed air for industrial use. The dryer cannot be used in premises where there is a risk of fire or explosion or where work is carried out which releases substances into the environment which are dangerous with regard to safety (for example: solvents, inflammable vapours, alcohol, etc.).

In particular the appliance cannot be used to produce air to be breathed by humans or used on direct contact with foodstuffs. These uses are only allowed if the compressed air is additionally treated by means of a suitable purification system (Consult the manufacturer for these special uses.)

This appliance must be used only for the purpose for which it was specifically designed. All other uses are to be considered incorrect and therefore unreasonable. The Manufacturer cannot be held responsible for any damage resulting from improper, incorrect, or unreasonable use

3.0 OPERATION

The hot gaseous refrigerant leaves the evaporator (4) and enters the refrigeration compressor (1) where it is compressed and pumped into the condenser (2). With the aid of a cooling fan (3) the refrigerant is condensed into a liquid. The condensed liquid refrigerant then passes through a filter/dryer (8) to remove any residual moisture. A capillary tube (7) is used as an expansion device before the refrigerant re-enters the evaporator (4). The expansion and evaporation of the refrigerant produces a cooling effect. Due to the heat exchange with the compressed air passing through the heat exchanger, the air temperature is reduced causing water vapour to condense out of the air stream. The water is removed in a water separator (5) so that it can be evacuated through the automatic level drain (13). The now gaseous refrigerant is returned to the compressor (1) where the cycle repeats.

The circuit is equipped with a hot gas bypass (HGBP) system for the refrigerant which adjusts the available refrigerating capacity to the actual cooling load. This is achieved by injecting hot gas under the control of the HGBP valve (9) to maintain a constant refrigerant pressure in the evaporator. With this control the of the refrigeration pressure the temperature never decreases below (32°F / 0°C) in order to prevent the condensate from freezing inside the evaporator. The dryer runs completely automatically; it is calibrated in the factory for a dew point of (37.4 - 45°F / 3 - 6 °C) and therefore no further calibrations are required by the user.

DRYER FLOW DIAGRAM

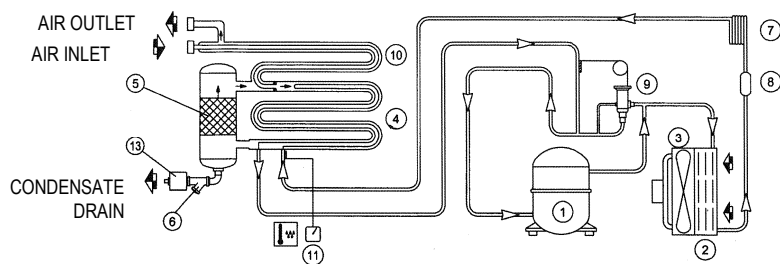

1) REFRIGERANT COMPRESSOR	7) EXPANSION CAPILLARY TUBE
2) CONDENSER	8) REFRIGERANT FILTER
3) MOTOR FAN	9) HOT GAS BYPASS VALVE
4) EVAPORATOR	10) AIR-TO-AIR EXCANGER
5) DEMISTER CONDENSATE SEPARATOR	11) DIGITAL CONTROLLER
6) IMPURITY TRAP	13) CONDENSATE DRAIN

4.0 GENERAL SAFETY STANDARD

The appliance may be used only by specially trained and authorized personnel.
 Any tampering with the machine or alterations not approved beforehand by the Manufacturer relieve the latter of responsibility for any damage resulting from the above actions.
 The removal of or tampering with the safety devices constitutes a violation of the European Standards on safety.



ALL WORK ON THE ELECTRONICS AND REFRIGERANT CIRCUIT, HOWEVER SLIGHT, MUST BE CARRIED OUT BY PROFESSIONALLY LICENSED PERSONNEL.

5.0 DESCRIPTION OF WARNING SYMBOLS



6.0 DANGER ZONES

6.1 DANGER ZONES

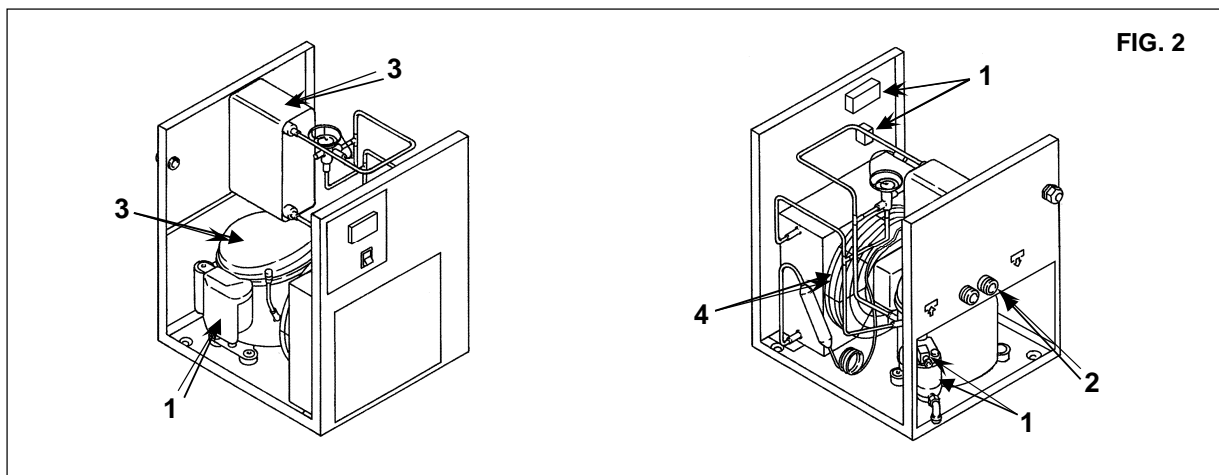
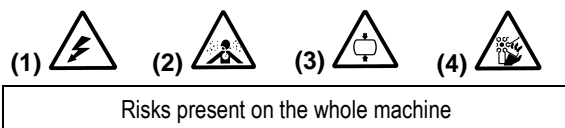

7.0 SAFETY DEVICES

7.1 SAFETY DEVICES

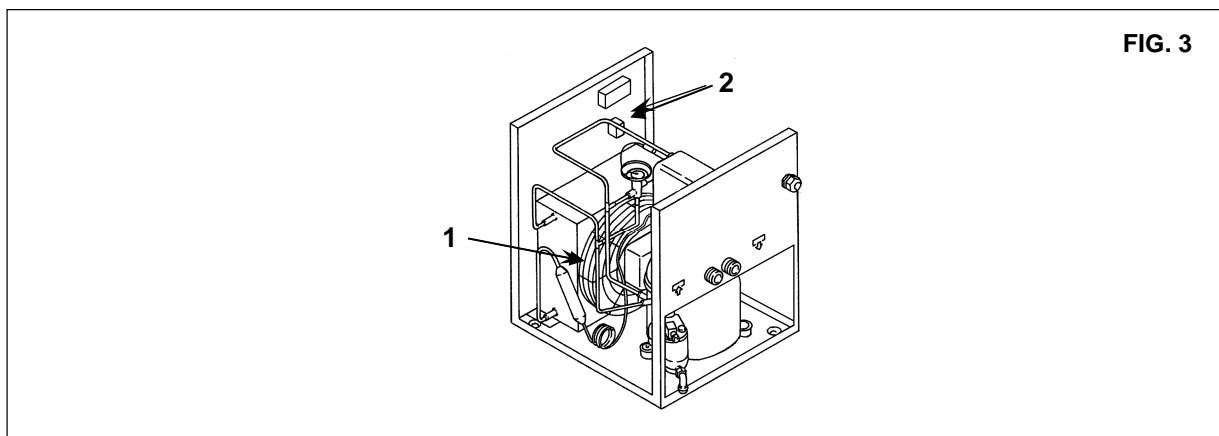

ENGLISH

8.0 POSITION OF LABELS

8.1 POSITION OF THE WARNING LABELS (Fig. 4)

The warning labels affixed to the compressor unit are part of the machine; they have been applied for safety purposes and must not be removed or spoiled for any reason.

Ref.1 - Spare plate Code 1079 9926 55

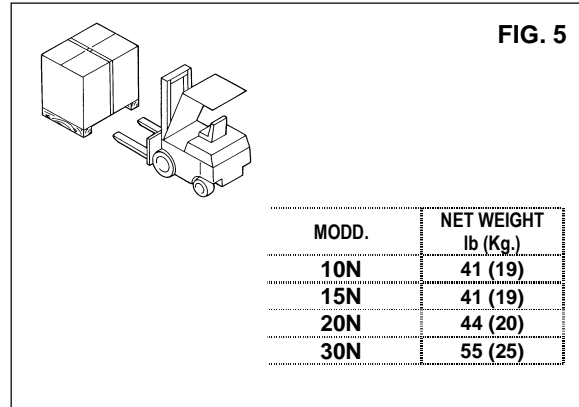
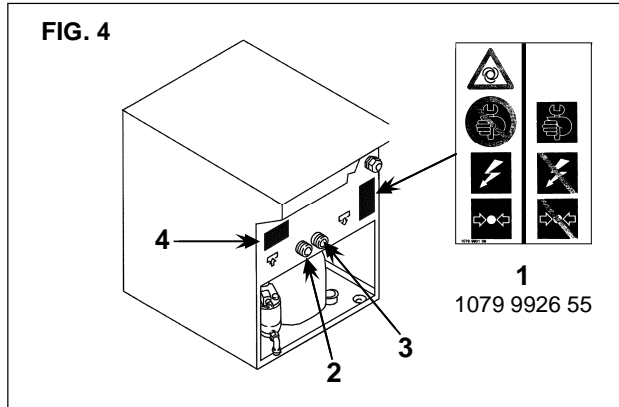

8.2 POSITION OF THE DATA LABELS (Fig. 4)

2) Compressed air inlet	4) Identification plate
3) Compressed air outlet	

9.0 INSTALLATION LOCATION

9.1 FLOOR

The floor must be level and be of a type that can suitably support the total weight of the machine as shown in Fig. 5.

Remember the total weight of the machine when positioning it.

9.2 VENTILATION

The choice of an appropriate room will prolong the life of your dryer; the room must be spacious, dry, well ventilated and free from dust.

The operating conditions to be complied with are the following:

Min. room temperature: + 41 °F (+ 5 °C) (compulsory)	Min. temperature of incoming air: 50 °F (10 °C)
Max. room temperature: + 113°F (+ 45 °C) (compulsory)	Max. working pressure: 232 psi (16 bar)
Max. temperature of incoming air: 131 °F (55 °C)	

- Please keep environmental conditions stable (temperature and humidity) in order to avoid refrigerant compressor/fan overload and/or reduction of dryer performance. Similar failures shall affect warranty reimbursements.
- Please ensure the appropriate composition of the air within the machine room: - clean with no damaging contaminants (e.g., dust, fibers, fine sand) - free of explosive or chemically unstable gases or vapors - free of acid/alkaline forming substances, particularly ammonia, chlorine or hydrogen sulfide. Similar failures shall affect warranty reimbursements.
- Please note that we do not recommend the use of ducting for the cooling air on these units.

10.0 TRANSPORT AND HANDLING

The machine must be transported as shown in the following fig. 5.

11.0 UNPACKING



CUTTING THE METAL STRAPPING CAN BE DANGEROUS. CUT PIECES SHOULD BE PROPERLY DISPOSED.

After removing the packing, ensure that the machine is unbroken and that there are no visibly damaged parts.

If you are in doubt, do not use the machine and contact your dealer or the manufacture for technical assistance.

The packing material (plastic bags, polystyrene foam, nails, screws, wood, metal strapping, etc.) must not be left within the reach of children or abandoned in the environment, as they are a potential source of danger and pollution. Dispose of these materials in the approved collection centres.

12.0 INSTALLATION

12.1 POSITIONING

After unpacking the equipment and preparing the installation location, put the machine into position, ensuring that there is sufficient space around the machine to allow maintenance (see Fig. 6).

12.2 ELECTRICAL CONNECTION

- Check that the supply voltage is the same as the value indicated on the machine data plate.
- Check the condition of the line leads and ensure that there is an efficient earth lead.
- **Ensure that there is a fused disconnect or appropriately sized breaker to protect the machine against over-currents, (Ref. 1 Fig. 6), For details (size and type) see wiring/service diagram.**



ONLY PROFESSIONALLY LICENSED PERSONNEL SHOULD ACCESS THE ELECTRIC PANEL. SWITCH OFF THE POWER BEFORE OPENING THE DOOR OF THE ELECTRIC PANEL AND PERFORM LOCK-OUT TAG-OUT PRIOR TO PERFORMING ANY WORK ON THE MACHINE. COMPLIANCE WITH THE REGULATIONS IN FORCE CONCERNING ELECTRICAL WORK IS FUNDAMENTAL FOR OPERATOR SAFETY AND FOR THE PROTECTION OF THE MACHINE.

12.3 CONNECTION TO THE COMPRESSED AIR NETWORK

Install isolation valves (not supplied) between the machine and the compressed air network so that the dryer may be isolated during maintenance operations. Plumb the condensate auto-drain, Ref. (2) Fig. 7, to a location where it can be treated prior to disposal. Condensate must be disposed of according to the local rules and regulations in the location of the installation.

- All refrigerant dryers shall be equipped with proper pre-filter at closest position to dryer air inlet. The filter should be replaced annually or sooner for installations with high contaminate levels or ambient humidity.



ALL DAMAGE DUE TO THE FAILURE TO COMPLY WITH THESE INDICATIONS CANNOT BE ATTRIBUTED TO THE MANUFACTURER AND MAY LEAD TO THE VOIDING OF THE MACHINE WARRANTY.

12.4 STARTING UP

See part B of this manual, Section 18.0

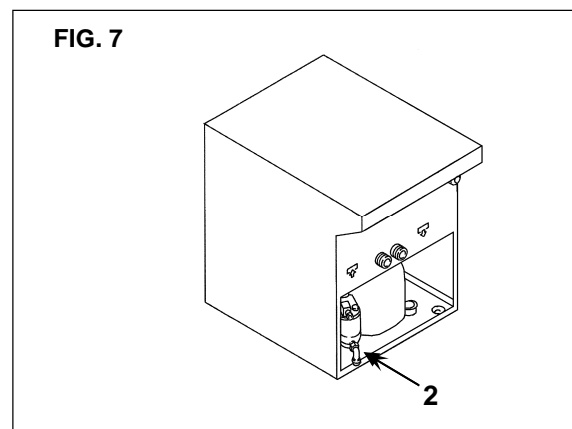
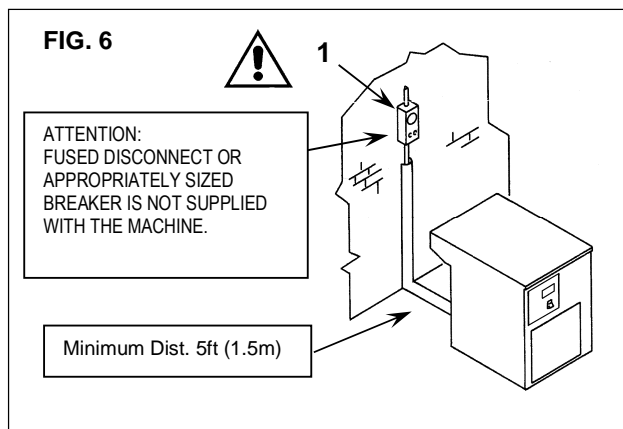

13.0 DIMENSIONS AND TECHNICAL DATA

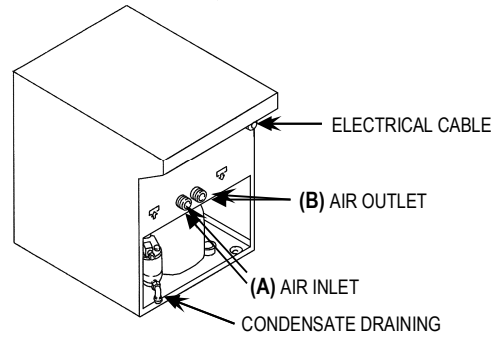
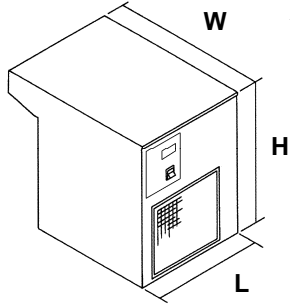

TYPE	mm (in)		
	L	W	H
10N	350 (13.78)	500 (19.69)	450 (17.72)
15N	350 (13.78)	500 (19.69)	450 (17.72)
20N	350 (13.78)	500 (19.69)	450 (17.72)
30N	350 (13.78)	500 (19.69)	450 (17.72)

Refrigerant gas ⁽¹⁾	GWP ₁₀₀ ⁽²⁾
R-513A	631

⁽¹⁾ According to ISO 817
⁽²⁾ According to EN-378-1

TYPE	A	B
	NPT	
10N	1/2-14 Male	1/2-14 Male
15N	1/2-14 Male	1/2-14 Male
20N	1/2-14 Male	1/2-14 Male
30N	1/2-14 Male	1/2-14 Male

TYPE	Net Weight lb. (Kg.)	Refrigerant R513A lb. (Kg.)		Nominal Power kW	Nominal Power kW	Nominal Power kW	MAX. psi (bar)
		115V	230V				
10N	41.9 (19)	0.353 (0.160)	0.375 (0.170)	0.16	0.029	0.19	232 (16)
15N	41.9 (19)	0.397 (0.180)	0.375 (0.170)	0.15	0.029	0.18	232 (16)
20N	44.1 (20)	0.639 (0.290)	0.639 (0.290)	0.20	0.029	0.23	232 (16)
30N	55.1 (25)	0.772 (0.350)	0.772 (0.350)	0.30	0.033	0.33	232 (16)

Reference conditions:	Limit conditions:
Ambient temperature: 100 °F (38 °C)	Max. ambient temperature: 113 °F (45 °C)
Inlet air temperature: 100 °F (38 °C)	Min. ambient temperature: 41 °F (5 °C)
Working pressure: 102 psi (7 bar)	Max. inlet air temperature: 131 °F (55 °C)
	Max. working pressure: 232 psi (16 bar)

14.0 MACHINE ILLUSTRATION

FIG. 8

14.1 GENERAL LAY-OUT

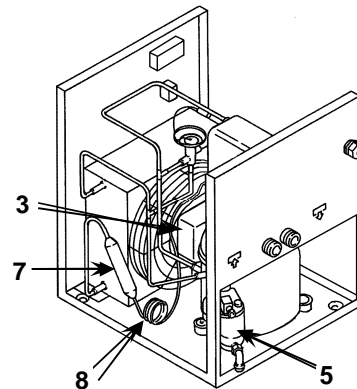
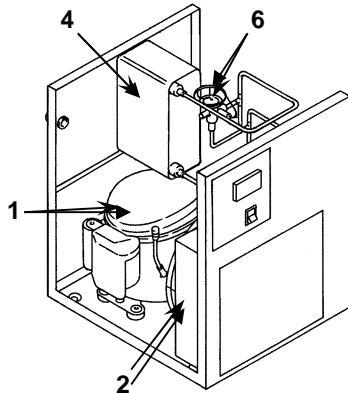

1	Refrigerant compressor
2	Condenser
3	Motor fan
4	Evaporator
5	Condensate drain
6	Hot gas by-pass valve
7	Refrigerant filter
8	Expansion capillary tube

14.2 COMMAND AND CONTROL PANEL

BEFORE OPERATING THE UNIT, CAREFULLY READ AND ACQUIRE A WORKING KNOWLEDGE OF THE COMMAND FUNCTIONS.

FIG. 9

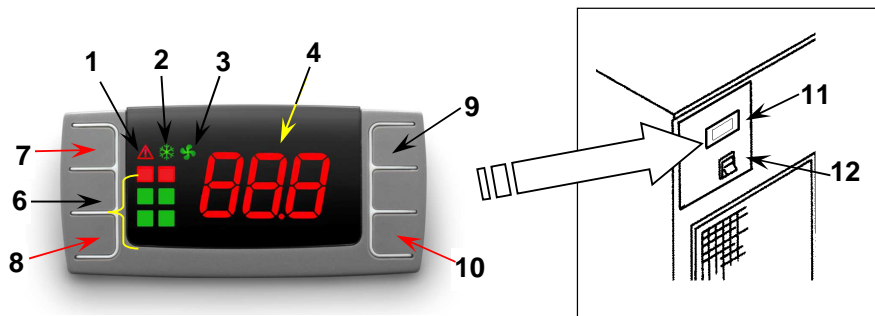

Reference	Name
1	ALARM ICON
2	POWER ON
3	FAN ICON
4	DRYER ON
6	PDP INDICATOR
7	BUTTON TO SNOOZE OR TO RESET THE ALARM
8	SET BUTTON
9	UP BUTTON
10	DOWN BUTTON
8 + 9	BACK TO PREVIOUS SCREEN
8 + 10	MENU
11	DIGITAL CONTROLLER
12	SWITCH

	ICON	MODE	FUNCTIONS
	ALARM	OFF	No active alarms
		ON	Probe failure alarm
		FLASH	High/Low temperature alarm
	COMPRESSOR	OFF	Dryer off
		FLASH	Maintenance warning
		ON	Dryer on
	FAN	OFF	Fan off
		FLASH	n/a
		ON	Fan on

REMOTE ALARM FUNCTION

The controller allows to remotely access an alarm signal. This is managed by means of a free NC (Normally Closed) contact. The contact opens in case of an alarm or when the dryer is switched off. Refer to the table below to identify the availability of the function and refer to the related picture Fig. 9a Ref. 1 to identify the physical location of the free contact connector.

10N – 20N : Is possible remote alarm for P2, L2 and H2. For the details of alarm see Sect. 17.1, Pg 11.

30N : Is possible remote alarm for P1, P2, L2 and H2. For the details of alarm see Sect. 17.1, Pg 11.



FIG. 9a

Location of the free contact connector (1)

SILENT ALARM FUNCTION

To snooze the alarm, press button Ref. 7 (See Fig. 9)

15.0 DISPOSING OF THE UNIT

If the machine is to be scrapped, it must be dismantled into parts of the same material, to be disposed of according to the local regulations in force.

ALWAYS RESPECT THE REGULATIONS IN FORCE FOR DISPOSING OF OLD OIL AND OTHER POLLUTING MATERIALS SUCH AS INSULATING FOAM, ETC.



SPECIAL CARE NEEDS TO BE TAKEN IN REGARDS TO THE REFRIGERANT WITHIN THE UNIT. IT SHOULD NOT BE RELEASED TO THE ATMOSPHERE. ALL REFRIGERANTS SHOULD BE RECLAIMED BY A PROPERLY CERTIFIED REFRIGERANT TECHNICIAN PRIOR TO THE UNIT BEING SCRAPPED.

PART "B"



THIS PART "B" OF THE INSTRUCTIONS MANUAL IS RESERVED FOR PROFESSIONALLY TRAINED AND LICENSED PERSONNEL APPROVED THE MANUFACTURER.

16.0 ROUTINE MAINTENANCE



BEFORE CARRYING OUT ANY MAINTENANCE JOBS IT IS OBLIGATORY TO STOP THE MACHINE, DISCONNECT IT FROM THE POWER SOURCE AND ISOLATE THE UNIT FROM THE COMPRESSED AIR DISTRIBUTION NETWORK.

16.1 MAINTENANCE SCHEDULE

These maintenance intervals are recommended for work environments that are not dusty and are well ventilated. For particularly dusty environments, double the frequency of the recommended service intervals.

Every week	■ ■	Brush/blow off the finned surface of the condenser
	■ ■	Clean the filter of the automatic condensate drain
Every 2000 hours / 1 year	■ ■	Replace the filter of automatic condensate drain (2902016102)
Every 4000 hours / 1 year	■ ■	Replace drain kit (2200902017)

16.2 CLEANING OF THE AUTOMATIC CONDENSATE DRAIN FILTER (Fig. 10)

Proceed as follows:

- Isolate the unit from the compressed air network Ref.1 Fig.10.
- Release the pressure in the dryer by pressing the condensate drain "TEST" button located on the drain Ref. 2 Fig. 10.
- Switch off the machine by pressing the STOP button Ref. 3 Fig. 10
- Lock-out and tag-out the unit at the fuse/breaker box.Ref. 4 Fig. 10



WARNING - COMPONENTS INSIDE THE UNIT MAY STILL BE HOT

- Remove the panels Ref. 5
- Remove the stopper Ref. 6
- Remove the filter Ref. 7
- Clean the filter Ref. 7 with a jet of air, working from inside to outside
- Re-install the filter, fix the plug Ref. 7 - 6
- Close the panels Ref. 5

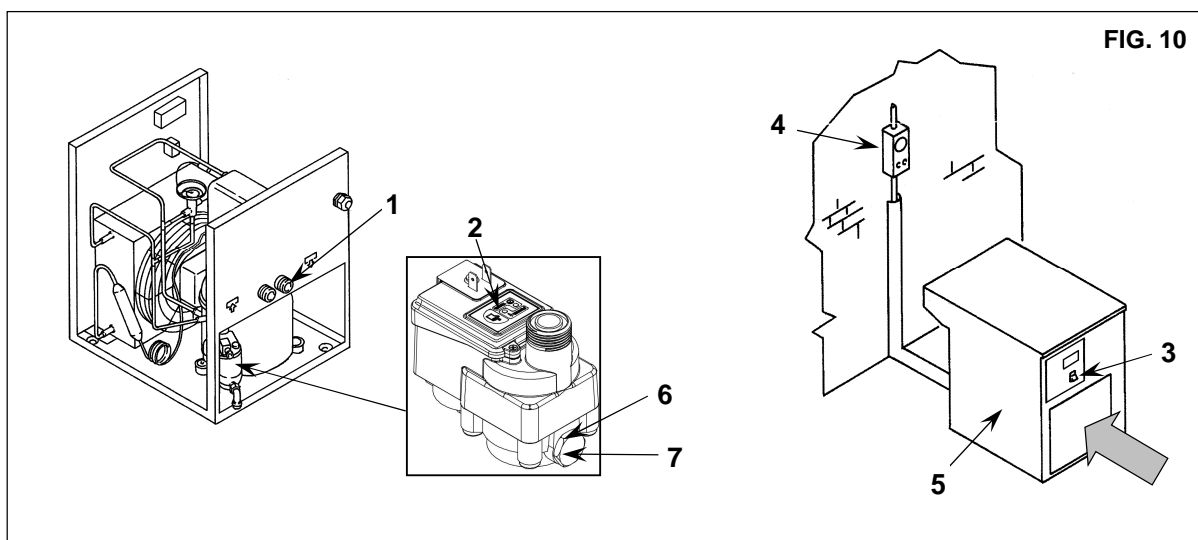

ENGLISH

16.3 CLEANING THE CONDENSER (Fig. 10)

The condenser must be cleaned every month.

Proceed as follows:

- Switch off the machine by pressing the STOP button Ref. 3 Fig. 10
- Lock-out and tag-out the unit at the fuse/breaker box. Ref. 4 Fig. 10
- Remove the panels Ref. 5 Fig. 10
- Clean the condenser fins Ref. 2 with compressed air (Fig. 8) **DO NOT USE WATER OR SOLVENTS**
- Close the panels Ref. 5 Fig. 10

17.0 TROUBLE-SHOOTING AND EMERGENCY REMEDIES













ALL WORK MUST BE CARRIED OUT BY PROFESSIONALLY TRAINED AND LICENSED PERSONNEL. BEFORE CARRYING OUT ANY MAINTENANCE JOBS IT IS OBLIGATORY TO STOP THE MACHINE AND DISCONNECT IT FROM THE POWER SOURCE.

N.B. OPERATIONS MARKED ■ ■ MUST BE CARRIED OUT BY PROFESSIONALLY TRAINED AND LICENSED PERSONNEL APPROVED BY THE MANUFACTURER

FAULT FOUND	POSSIBLE CAUSES	OBSERVATIONS
1) No compressed air passes through the dryer outlet	1A) The pipes are frozen inside	<ul style="list-style-type: none"> ■ ■ -The bypass valve of the hot gas is broken or out-of-calibration -The room temperature is too low and the evaporators piping are obstructed with ice
2) Presence of condensate in the pipings.	2A) The condensate separator does not work correctly 2B) The dryer is working outside its rated capacity 2C) The dryer refrigeration condenser is not working properly	<ul style="list-style-type: none"> - Clean the filter from the condensate drain ■ ■ -Check the condensate drain -Check the flow rate of treated air -Check the room temperature -Check the air temperature at the drier inlet. -Clean the condenser. ■ ■ -Check the good operation of the fan.
3) The compressor head is very hot (> 55 °C)	Make reference to 2B Make reference to 2C 3A) The cooling circuit is not working with the right gas charge	<ul style="list-style-type: none"> ■ ■ -Check if there are leaks of refrigerating gas. ■ ■ - Charge it again.
4) Motor shuts off on overload	Make reference to 2B Make reference to 2C Make reference to 3A	
5) The motor hums and does not start.	The line voltage is too low. You switched the machine off and on again without leaving enough time for the pressure balancing. The starting system of the motor is defective.	<ul style="list-style-type: none"> -Contact the electric power company -Wait a few minutes before starting the machine again. ■ ■ -Check the running and starting relays and condensers (if any)
6) The machine has stopped and does not restart even after a few minutes.	The overload protection with has intervened: make reference to 2B-2C-3A. The motor has burnt out.	-Contact authorized service provider
7) The compressor is very noisy.	Troubles with the internal mechanical parts	-Contact authorized service provider

17.1 DIGITAL CONTROL ALARMS

N.B. OPERATIONS MARKED ■■ MUST BE CARRIED OUT BY PROFESSIONALLY SKILLED PERSONNEL APPROVED THE MANUFACTURER

Display	Flashing fault message	Description	Possible root causes	Observations
		Dryer is working OK	n/a	
		Warning icon NOT flashing, label P1 flashing	Fan control probe failed	■■ replace probe
		Warning icon NOT flashing, label P2 flashing	PDP Temp probe failed	■■ replace probe
		Warning icon NOT flashing, label P3 flashing	Refrigerant compressor temperature probe failed	■■ replace probe
		Warning icon NOT flashing, label H2 flashing	High PDP	■■ refrigerant leak ■■ flow rate / inlet ■■ temperature exceeding the limit. ■■ call for service
		Warning icon NOT flashing, label L2 flashing	Low PDP	■■ hot gas by pass valve out of order. ■■ ambient temperature lower then limits ■■ call for service
		Warning icon NOT flashing, label H3 flashing	High refrigerant compressor temperature	■■ refrigerant leak ■■ call for service
		Warning icon NOT flashing, label H1 flashing	High temperature discharge condenser	■■ check probe ■■ call for service
		Warning icon NOT flashing, label L1 flashing	Low temperature discharge condenser	■■ check probe ■■ call for service

EE ALARM

EE alarm is shown when internal EPROM errors happens, the dryer will stop running when this warning occurs.. The error can be reset by pressing one of the four buttons of the controller, but if it persists the controller must be replaced.



NOTE: In case of EE alarm please contact your tech support.

SE ALARM









After 6000Hrs, the controller will issue a "SE" warning. This is the maintenance due warning.



How to reset the maintenance warning: follow steps 1 to 12

<p>1</p> <p>PDP is flashing between standard view and "SE" alarm</p>	<p>2</p> <p>Push and hold buttons "SET" and "DOWN" to enter in the menu.</p>	<p>3</p> <p>Message "SE" appears on display.</p>
<p>4</p> <p>Push and release button "UP".</p>	<p>5</p> <p>Message "rS" appears on display.</p>	<p>6</p> <p>Push and release button "SET".</p>
<p>7</p> <p>Message "n" appears on display.</p>	<p>8</p> <p>Push and release button "UP".</p>	<p>9</p> <p>Message "y" appears on display.</p>
<p>10</p> <p>Push and release "SET" to reset service alarm.</p>	<p>11</p> <p>Message "y" blinks for 3 seconds.</p>	<p>12</p> <p>Then "rL" is fixed and "°C" blinks on display for ~10 seconds. Service alarm is reset</p>

PROCEDURE TO SET THE SERVICE INTERVAL ON PDP DEVICE

<p>1</p>  <p>PDP is showing standard view.</p>	<p>2</p>  <p>Push and hold buttons "SET" and "DOWN" to enter in the menu.</p>	<p>3</p>  <p>Message "SE" appears on display.</p>
<p>4</p>  <p>Push and release "SET" to enter in the "SE" menu.</p>	<p>5</p>  <p>Current service interval is displayed. ("60" or different value from "0" to "99")</p>	<p>6</p>  <p>Select desired service interval using "UP" or "DOWN". (40=4000h, 55=5500h, 80=8000h,...)</p>
<p>7</p>  <p>Push and release "SET" to configure new service interval.</p>	<p>8</p>  <p>Value selected blinks for 3 seconds.</p>	<p>9</p>  <p>Then "rS" is fixed and "°C" blinks on display for ~10 seconds. New service interval is set</p>

18.0 STARTING UP

BEFORE CARRYING OUT ANY OPERATION ON THE MACHINE, ENSURE THAT THE ELECTRIC POWER SUPPLY HAS BEEN DISCONNECTED

18.1 PRELIMINARY CONTROLS

Before starting the dryer, check:

- The correct connection to the compressed air piping: remember to remove protected caps supplied on the drier inlet and outlet.
- The correct connection to the condensate drainage system.
- That the power supply matches the power supply indicated on the dryer nameplate.

18.2 STARTING AND STOP

Start the system before the air compressor starts running and stop it after the air compressor has been stopped. The compressed air piping will be free of condensate only by doing so. The drier must be kept running during all the time the air compressor is running. **WARNING:** if the drier is switched off, before starting it again, wait at least 5 minutes in order to allow the pressure balancing.



IF THE DRYER IS SWITCHED OFF, BEFORE STARTING IT AGAIN, WAIT AT LEAST 5 MINUTES IN ORDER TO ALLOW THE PRESSURE BALANCING.

BEFORE CARRYING OUT ANY MAINTENANCE JOBS IT IS MANDATORY TO STOP THE MACHINE, DISCONNECT IT FROM THE POWER SOURCE AND ISOLATE IT FROM THE COMPRESSED AIR DISTRIBUTION NETWORK.

PRESSURE DISCHARGE PROCEDURE (Fig. 10)

Proceed as follows:

- Isolate the unit from the compressed air network Ref. 1 Fig. 10
- Release the pressure in the dryer by pressing the condensate drain "TEST" button located on the drain Ref. 2 Fig. 10
- Switch off the machine by pressing the STOP button Ref. 3 Fig. 10
- Lock-out and tag-out the unit at the fuse/breaker box. Ref. 4 Fig. 10

CALIBRATIONS

BYPASS VALVE FOR HOT GAS

N.B. These valves have already been calibrated and they do not require any adjustment. An operating dew point that is different from the standard rated performance is typically caused by conditions other than the hot gas bypass valve.

Ref. 1) Closing cap

Ref. 2) Adjusting screw

WORKING PRESSURES AND TEMPERATURES OF R513A

	SUCTION SIDE OF REFRIGERATION COMPRESSOR	
	Evaporat. Temperat. ° F (°C)	Evaporating Pressure psi (bar)
RATED VALUES Temp. 68°F (20 °C)	23 - 41 (-0,5 - +0.5)	R513A 31,62 - 33,21 (2,18 - 2,29)

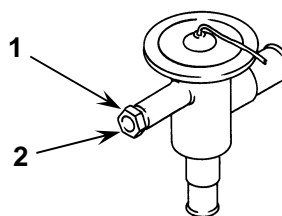



South-Tek Systems
www.southteksystems.com
Tel (888) 526-6284