

Code
9828093585-G-ST00
Edit. 11/2021

INSTRUCTION AND MAINTENANCE MANUAL

DRYERS

325N – 400N - 500N - 600N

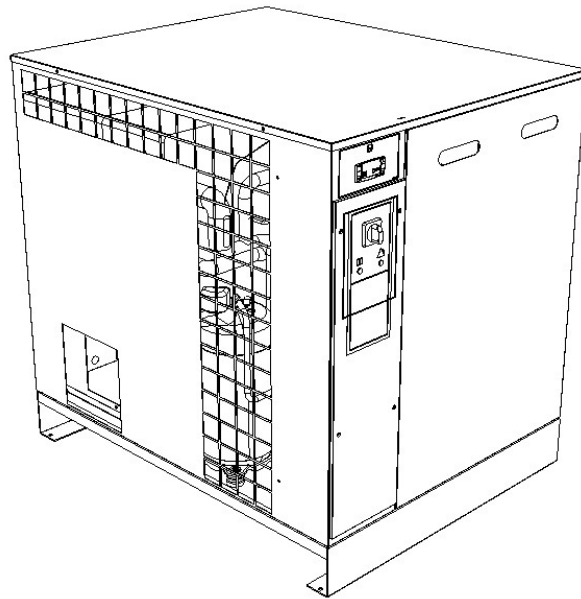

READ THIS MANUAL CAREFULLY BEFORE CARRYING OUT ANY OPERATIONS ON THE DRYER.

CONTENTS

PART A: INFORMATION FOR THE USER

- 1.0 GENERAL CHARACTERISTICS
- 2.0 INTENDED USE
- 3.0 OPERATION
- 4.0 GENERAL SAFETY STANDARDS
- 5.0 DESCRIPTION OF WARNING SYMBOLS
- 6.0 DANGER ZONES
- 7.0 SAFETY DEVICES
- 8.0 POSITION OF PLATES
- 9.0 INSTALLATION LOCATION
- 10.0 TRANSPORT AND HANDLING
- 11.0 UNPACKING
- 12.0 INSTALLATION
- 13.0 DIMENSIONS AND TECHNICAL DATA
- 14.0 MACHINE ILLUSTRATION
- 15.0 DISPOSING OF THE DRYERS

PART B: INFORMATION RESERVED FOR TECHNICALLY SKILLED PERSONNEL

- 16.0 ROUTINE MAINTENANCE
- 17.0 TROUBLE-SHOOTING AND EMERGENCY REMEDIES
- 18.0 STARTING UP, FREE CONTACT FEATURES

ATTENTION: THERE IS A COPY OF THE WIRING DIAGRAM INCLUDED WITH THE UNIT

ADDRESSES OF ASSISTANCE CENTRES

In the event of breakdown or malfunction of the dryer, switch it off and do not tamper with it. If repairs are needed, contact your dealer or the manufacture for an approved service contact and insist on the use of original spare parts. Failure to comply with the above may impact the safety and operation of the machine.

INTRODUCTION

Keep this manual for future consultation; the use and maintenance manual is an integral part on the dryer. Read this manual carefully before carrying out any operations on the dryer. The installation of the dryer and all operations involving it must be performed in conformity with the regulations in force concerning electronics and refrigerant circuit and personal safety.

CHARACTERISTICS AND SAFETY PRECAUTIONS



BEFORE REMOVING THE PROTECTIVE GUARDS TO CARRY OUT ANY MAINTENANCE ON THE MACHINE, SWITCH OFF THE ELECTRIC POWER SUPPLY AND DISCHARGE THE RESIDUAL PRESSURE INSIDE THE UNIT. ALL WORK ON THE ELECTRICAL CONNECTIONS, HOWEVER SLIGHT, MUST BE CARRIED OUT BY PROFESSIONALLY SKILLED PERSONNEL.

The manufacturer does not accept responsibility for damage caused as a result of negligence of failure to abide by the instructions given above.

THIS MACHINE IS NOT SUITABLE FOR OUTDOOR INSTALLATION

THIS MACHINE CORRESPONDS TO THE ESSENTIAL SAFETY REQUIREMENTS FORESEEN FROM THE EUROPEAN STANDARD (2006/42 CE).

THE LUBRICATING LIQUIDS AND OTHER CONDENSATE FLUIDS MUST NOT BE DISCHARGED IN THE ENVIRONMENT. THESE POLLUTING AND HAZARDOUS PRODUCTS MUST BE DISPOSED OF ACCORDING TO THE LOCAL RULES AND REGULATIONS IN THE LOCATION OF THE INSTALLATION.

1.0 GENERAL CHARACTERISTICS

The dryer is a chilling machine with direct expansion heat exchanger and dry evaporator. The air to be dried is sent to the heat exchanger in which the water vapour present is condensed: the condensate gathers in the separator and is discharged outside through an electronic level sensing drain.

2.0 INTENDED USE

The dryer has been designed and built to dry compressed air for industrial use. The dryer cannot be used in premises where there is a risk of fire or explosion or where work is carried out which releases substances into the environment which are dangerous with regard to safety (for example: solvents, inflammable vapours, alcohol, etc.). In particular the appliance cannot be used to produce air to be breathed by humans or used on direct contact with foodstuffs. These uses are only allowed if the compressed air is additionally treated by means of a suitable purification system

(Consult the manufacturer for these special uses.)

This appliance must be used only for the purpose for which it was specifically designed. All other uses are to be considered incorrect and therefore unreasonable. The Manufacturer cannot be held responsible for any damage resulting from improper, incorrect, or unreasonable use.

3.0 OPERATION

The hot gaseous refrigerant leaves the evaporator (4) and enters the refrigeration compressor (1) where it is compressed and pumped into the condenser (2). With the aid of a cooling fan (3) the refrigerant is condensed into a liquid. The condensed liquid refrigerant then passes through a filter/dryer (8) to remove any residual moisture. A capillary tube (7) is used as an expansion device before the refrigerant re-enters the evaporator (4). The expansion and evaporation of the refrigerant produces a cooling effect. Due to the heat exchange with the compressed air passing through the heat exchanger, the air temperature is reduced causing water vapour to condense out of the air stream. The water is removed in a water separator (5) so that it can be evacuated through the automatic level drain (13). The now gaseous refrigerant is returned to the compressor (1) where the cycle repeats.

The circuit is equipped with a hot gas bypass (HGBP) system for the refrigerant which adjusts the available refrigerating capacity to the actual cooling load. This is achieved by injecting hot gas under the control of the HGBP valve (9) to maintain a constant refrigerant pressure in the evaporator. With this control the of the refrigeration pressure the temperature never decreases below (32°F / 0°C).

DRYER FLOW DIAGRAM

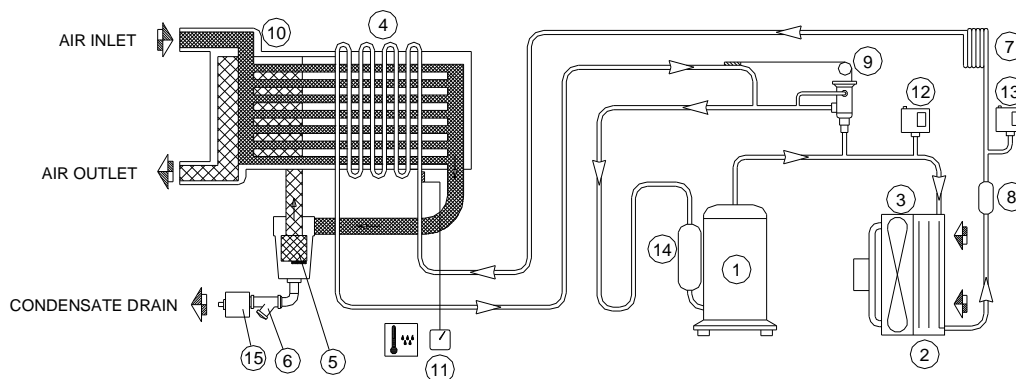

1) REFRIGERANT COMPRESSOR	9) HOT GAS BYPASS VALVE
2) CONDENSER	10) AIR-TO-AIR EXCHANGER
3) MOTOR FAN	11) DIGITAL CONTROLLER
4) EVAPORATOR	12) MAX PRESSURE SWITCH
5) DEMISTER CONDENSATE SEPARATOR	13) FAN CONTROL PRESSURE SWITCH
6) IMPURITY TRAP	14) LIQUID SEPARATOR
7) EXPANSION CAPILLARY TUBE	15) CONDENSATE DRAIN
8) REFRIGERANT FILTER	

4.0 GENERAL SAFETY STANDARD





The appliance may be used only by specially trained and authorized personnel. Any tampering with the machine or alterations not approved beforehand by the Manufacturer relieve the latter of responsibility for any damage resulting from the above actions. The removal of or tampering with the safety devices constitutes a violation of the European Standards on safety.



ALL WORK ON THE ELECTRONICS AND REFRIGERANT CIRCUIT, HOWEVER SLIGHT, MUST BE CARRIED OUT BY PROFESSIONALLY SKILLED PERSONNEL.

ENGLISH

5.0 DESCRIPTION OF WARNING SYMBOLS

				
1) Electrocution risk	2) Air not fit for breathing	3) High pressure	4) Fan rotating	5) Hot parts

6.0 DANGER ZONES

6.1 DANGER ZONES

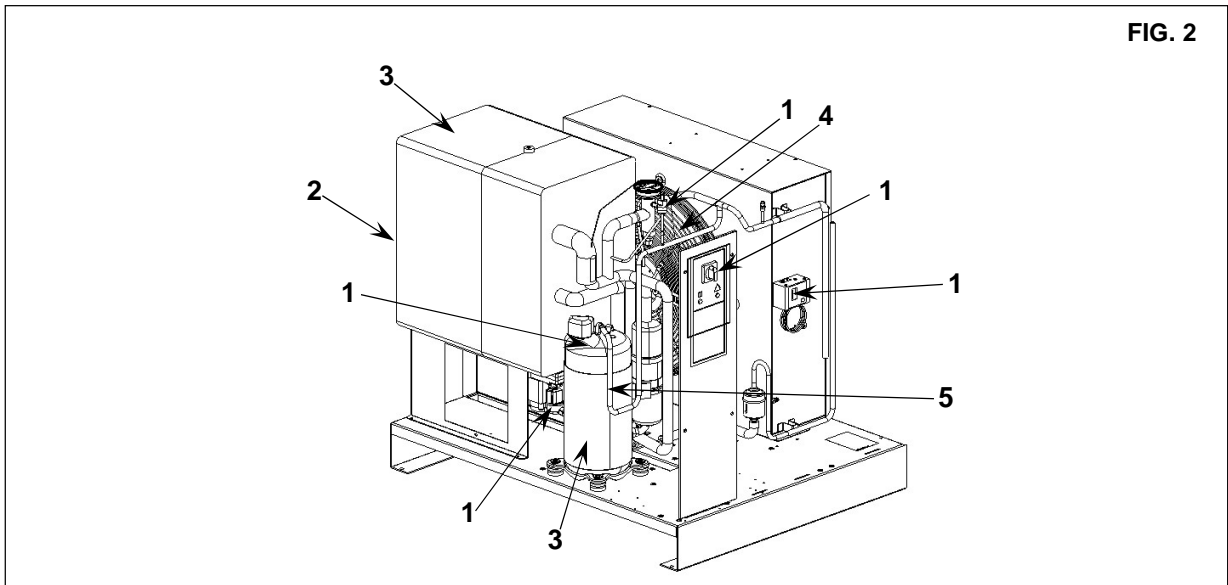
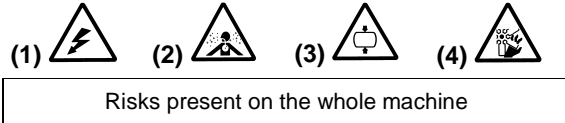

7.0 SAFETY DEVICES

7.1 SAFETY DEVICES

1) Cooling fan shield	3) Earth
2) high pressure side switch	

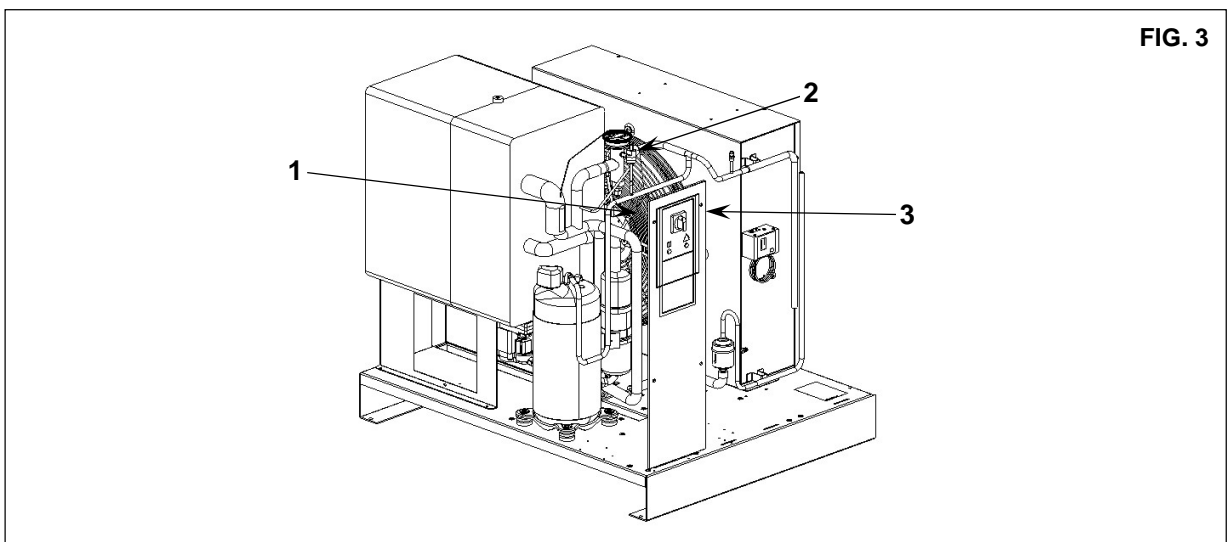

8.0 POSITION OF WARNING LABELS

8.1 POSITION OF THE WARNING LABELS (Fig. 4)

The plates fitted on the compressor unit are part of the machine; they have been applied for safety purposes and must not be removed or spoiled for any reason.

Ref.1 - Spare plate Code 1079 9903 48

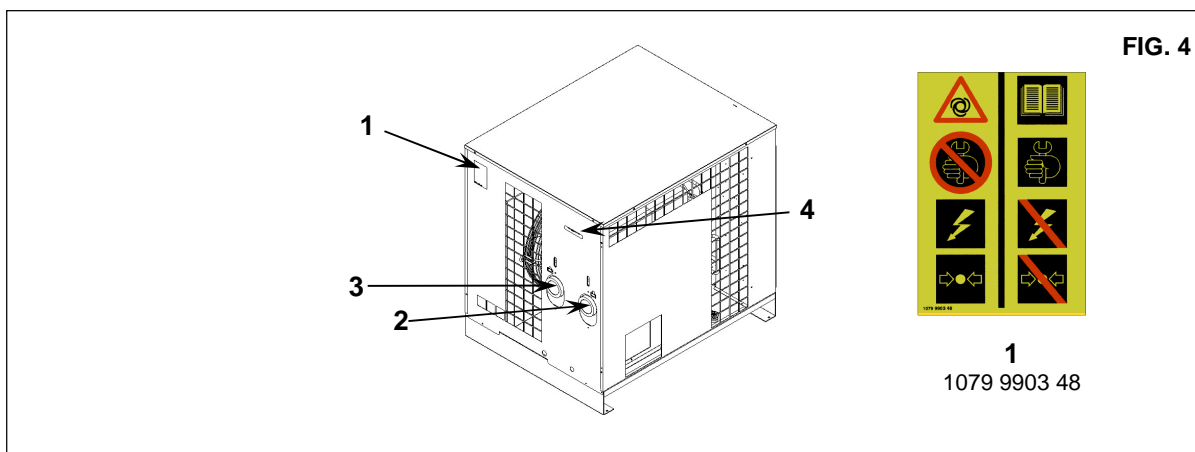

8.2 POSITION OF THE DATA PLATES (Fig. 4)

2) Compressed air inlet	4) Identification plate
3) Compressed air outlet	

9.0 INSTALLATION LOCATION

9.1 FLOOR

The floor must be level and be of a type that can suitably support the total weight of the machine as shown in Fig. 5 Remember the total weight of the machine when positioning it.

9.2 VENTILATION

The choice of an appropriate room will prolong the life of your dryer; the room must be spacious, dry, well ventilated and free from dust.

The operating conditions to be complied with are the following:

Min. room temperature: +37,4 °F (+ 3 °C) (compulsory)	Min. inlet allowed temperature: +37,4 °F (3°C)
Max. room temperature: +113 °F (+ 45 °C) (compulsory)	Max. working pressure: 203 psi (14 bar)
Max. temperature of incoming air: +131 °F (55 °C)	

- Please keep environmental conditions stable (temperature and humidity) in order to avoid refrigerant compressor/fan overload and/or reduction of dryer performance. Similar failures shall affect warranty reimbursements.
- Please ensure the appropriate composition of the air within the machine room: - clean with no damaging contaminants (e.g., dust, fibers, fine sand) - free of explosive or chemically unstable gases or vapors - free of acid/alkaline forming substances, particularly ammonia, chlorine or hydrogen sulfide. Similar failures shall affect warranty reimbursements.
- Please note that we do not recommend the use of ducting for the cooling air on these units.

10.0 TRANSPORT AND HANDLING

The machine must be transported as shown in the following figures.

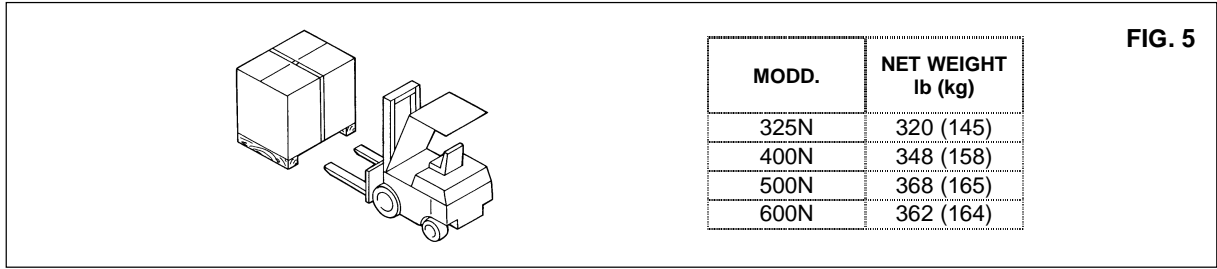

11.0 UNPACKING



CUTTING THE METAL STRAPPING CAN BE DANGEROUS OPERATION, CUT PIECES SHOULD BE PROPERLY DISPOSED.

After removing the packing, ensure that the machine is unbroken and that there are no visibly damaged parts.

If you are in doubt, do not use the machine and contact your dealer or the manufacture for technical assistance.

The packing material (plastic bags, polystyrene foam, nails, screws, wood, metal strapping, etc.) must not be left within the reach of children or abandoned in the environment, as they are a potential source of danger and pollution. Dispose of these materials in the approved collection centres.

12.0 INSTALLATION

12.1 POSITIONING

After unpacking the equipment and preparing the installation location, put the machine into position, checking the following items:

- ensure that there is sufficient space around the machine to allow maintenance (see Fig. 6).

ENSURE THAT THE OPERATOR CAN SEE THE WHOLE MACHINE FROM THE CONTROL PANEL AND CHECK THE PRESENCE OF ANY UNAUTHORIZED PERSONS IN THE VICINITY OF THE MACHINE.

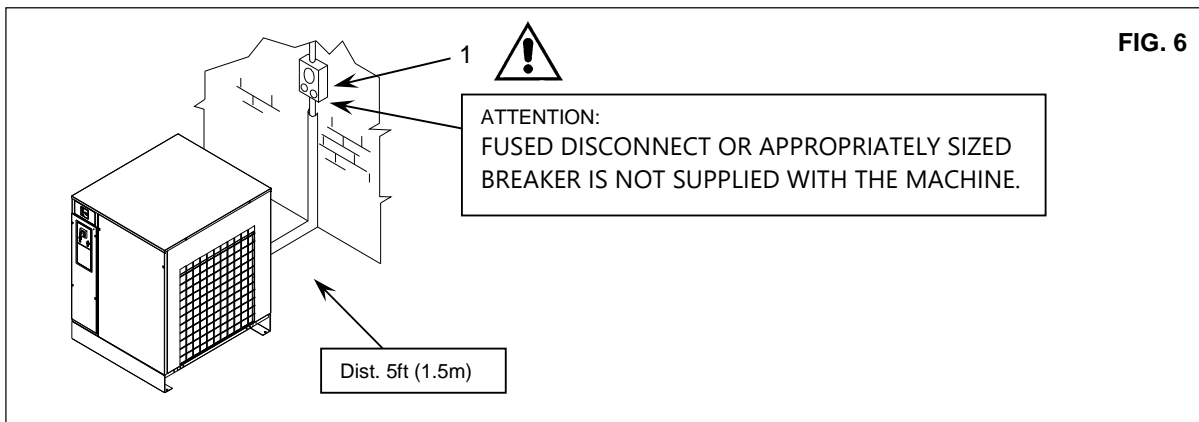

12.2 ELECTRICAL CONNECTION

- Check that the supply voltage is the same as the value indicated on the machine data plate.
- Check the condition of the line leads and ensure that there is a sufficient grounding line..
- **Ensure that there is a fused disconnect or appropriately sized breaker to protect the machine against over-currents, (Ref. 1 Fig. 6), wiring diagram.**



ONLY PROFESSIONALLY LICENSED PERSONNEL SHOULD ACCESS TO THE ELECTRIC PANEL. SWITCH OFF THE POWER BEFORE OPENING THE DOOR OF THE ELECTRIC PANEL. COMPLIANCE WITH THE REGULATIONS IN FORCE CONCERNING ELECTRICAL WORK PLANTS IS FUNDAMENTAL FOR OPERATOR SAFETY AND FOR THE PROTECTION OF THE MACHINE.

12.3 CONNECTION TO THE COMPRESSED AIR NETWORK

Install isolation valves (not supplied) Ref. 1 between the machine and the compressed air network so that the dryer may be isolated during maintenance operations (see figure 7).

Plumb the condensate auto-drain, Ref. (2) Fig. 7, to a location where it can be treated prior to disposal.

Condensate must be disposed of according to the local rules and regulations in the location of the installation.

- All refrigerant dryers shall be equipped with proper pre-filter at closest position to dryer air inlet. The filter should be replaced annually or sooner for installations with high contaminate levels or ambient humidity.



ALL DAMAGE DUE TO THE FAILURE TO COMPLY WITH THESE INDICATIONS CANNOT BE ATTRIBUTED TO THE MANUFACTURER AND MAY LEAD TO THE VOIDING OF THE MACHINE WARRANTY.

12.4 STARTING UP

See part B of this manual, section 16.0

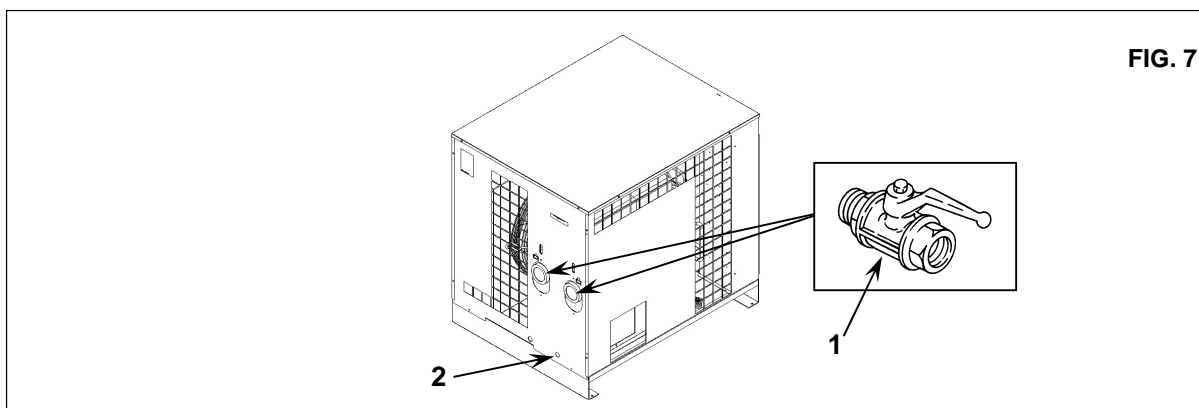

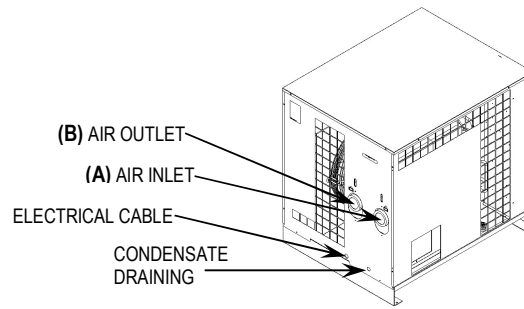
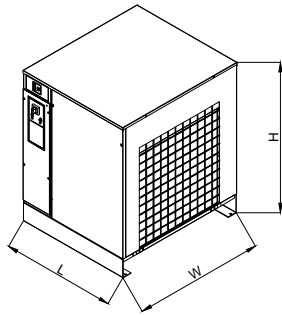

13.0 DIMENSIONS AND TECHNICAL DATA



TYPE	L (in / mm)	W (in / mm)	H (in / mm)
325N	31.7 (805)	41 (1040)	37.9 (962)
400N	31.7 (805)	41 (1040)	37.9 (962)
500N	31.7 (805)	41 (1040)	37.9 (962)
600N	31.7 (805)	41 (1040)	37.9 (962)

Refrigerant gas ⁽¹⁾	GWP ₁₀₀ ⁽²⁾
R-410A	2088
⁽¹⁾ According to ISO 817	
⁽²⁾ According to EN-378-1	

TYPE	A	B
325N	2" F.	2" F.
400N	2"1/2 F.	2"1/2 F.
500N	2"1/2 F.	2"1/2 F.
600N	2"1/2 F.	2"1/2 F.

TYPE	WEIGHT lb (kg)	Freon R410A Kg. lb (kg)	 Nominal Power W	 Nominal Power W	Nominal Power W	psi (bar) MAX.
325N	320 (145)	3,3 (1,5)	2460	210	2670	203 (14)
400N	348 (158)	3,5 (1,6)	2765	780	3585	203 (14)
500N	368 (165)	4,1 (1,85)	2681	780	3501	203 (14)
600N	362 (164)	4,3 (1,95)	3223	1100	4323	203 (14)

Reference conditions:	60 Hz	Limit conditions:	60 Hz
Ambient temperature	100°F (38 °C)	Max. ambient temperature	113°F (45 °C)
Inlet air temperature	100°F (38 °C)	Min. ambient temperature	37,4°F (3 °C)
Working pressure	101,5 psi (7 bar)	Max. inlet air temperature	131°F (55 °C)
		Max. working pressure	203 psi (14 bar)

14.0 MACHINE ILLUSTRATION

14.1 GENERAL LAY-OUT

1	Refrigerant compressor	7	Refrigerant filter
2	Condenser	8	Expansion capillary
3	Motor fan	9	Pressure switch of motor fan
4	Evaporator	10	Pressure switch of the high pressure
5	Condensate drain	11	Liquid separator
6	Hot gas by pass valve		

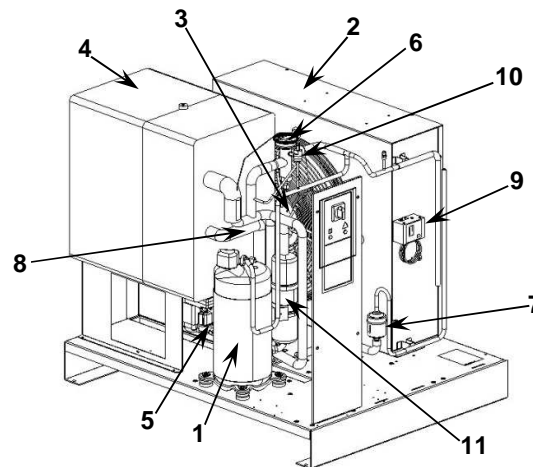
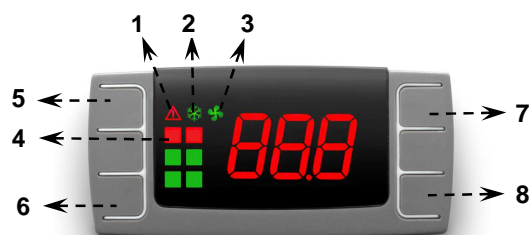

FIG. 8

14.2 DIGITAL CONTROLLER

Identification



Front panel of the controller

Reference	Name
1	Alarm icon
2	Refrigerant compressor icon
3	Fan icon
4	Alarm LED
5	Button to snooze or to reset the alarm
6	SET button
7	UP button
8	DOWN button
6+7	Back to previous screen
6+8	Menu

Icons

Icon	Name	Mode	Function
	Alarm	Off	No active alarms
		On	Probe failure alarm
			High temperature or low temperature alarm
	Refrigerant compressor	On	Dryer on
		Flashing + SE	Maintenance warning
		Flashing + L2	Dewpoint too low Dryer is stopped
		Flashing + H3	Too high discharge temperature of the refrigerant compressor (see further) Dryer is stopped
	Fan	Off	Fan off
		Flashing	Not applicable
		On	Fan on

ENGLISH**15.0 DISPOSING OF THE UNIT**

If the machine is to be scrapped, it must be dismantled into parts of the same material, to be disposed of according to the local regulations in force.

ALWAYS RESPECT THE REGULATIONS IN FORCE FOR DISPOSING OF OLD OIL AND OTHER POLLUTING MATERIALS SUCH AS INSULATING FOAM, ETC.



SPECIAL CARE NEEDS TO BE TAKEN IN REGARDS TO THE REFRIGERANT WITHIN THE UNIT. IT SHOULD NOT BE RELEASED TO THE ATMOSPHERE. ALL REFRIGERANTS SHOULD BE RECLAIMED BY A PROPERLY CERTIFIED REFRIGERANT TECHNICIAN PRIOR TO THE UNIT BEING SCRAPPED.

PART "B"



THIS PART "B" OF THE INSTRUCTIONS MANUAL IS RESERVED FOR PROFESSIONALLY SKILLED PERSONNEL APPROVED THE MANUFACTURER.

16.0 ROUTINE MAINTENANCE



BEFORE CARRYING OUT ANY MAINTENANCE JOBS IT IS OBLIGATORY TO STOP THE MACHINE AND DISCONNECT IT FROM THE POWER SOURCE AND ISOLATE THE UNIT FROM THE COMPRESSED AIR DISTRIBUTION NETWORK.

16.1 MAINTENANCE SCHEDULE

These maintenance intervals are recommended for work environments that are not dusty and are well ventilated. For particularly dusty environments, double the frequency of the recommended service intervals.

Every week	■ ■	Brush/blow off the finned surface of the condenser
	■ ■	Clean the filter of the automatic condensate drain
Every 2000 hours / 1 year	■ ■	Replace the filter of automatic condensate drain (2902016102)
Every 4000 hours / 2 year	■ ■	Replace drain kit (2200902017)

16.2 CLEANING OF THE AUTOMATIC CONDENSATE DISCHARGER FILTER (Fig. 10)

Clean the filter of the drain.

Proceed as follows:

- Isolate the unit from the compressed air network Ref. 1 Fig. 10
- Release the pressure in the dryer by pressing the condensate drain "TEST" button located on the drain Ref. 2 Fig. 10.
- Switch off the machine. Turn the switch in position STOP Ref. 3 Fig. 10
- Lock-out and tag-out the unit at the fuse/breaker box Ref. 4 Fig. 10



HOT PARTS INSIDE

- Access the drain through the drain access port Ref. 5
- Remove the stopper Ref. 6
- Remove the filter Ref. 7
- Clean the filter Ref. 7 with a jet of air, working from inside to outside
- Re-install the filter, fix the plug Ref. 7 - 6

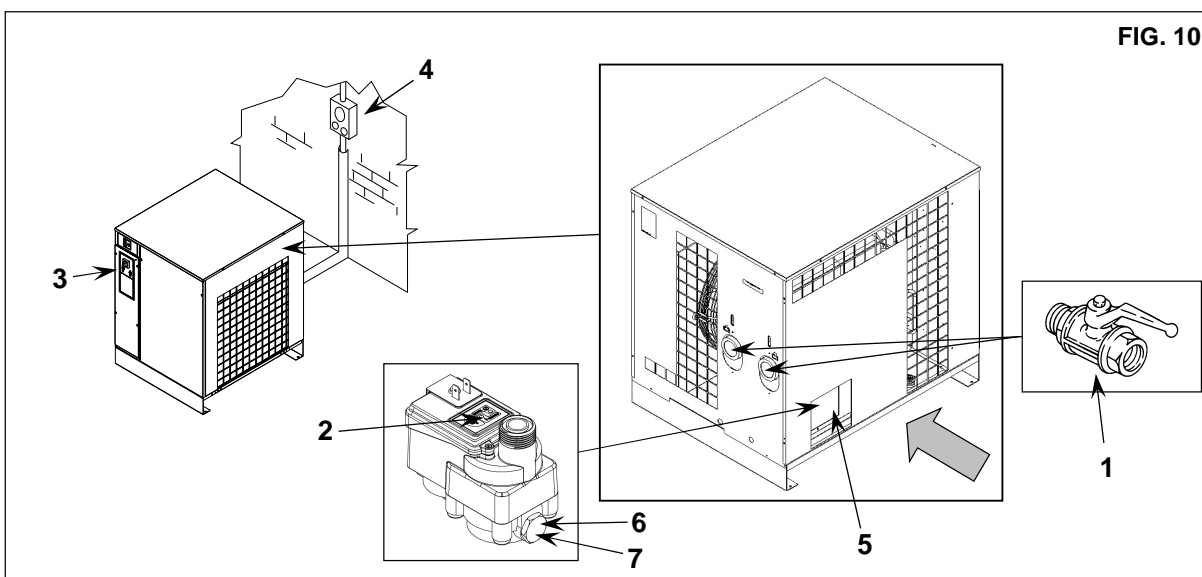

16.3 CLEANING THE CONDENSER (Fig. 10)

The condenser must be cleaned every month.
 Proceed as follows:

- Switch off the machine. Turn the switch in position STOP Ref. 3 Fig. 10
- Lock-out and tag-out the unit at the fuse/breaker box Ref. 4 Fig. 10
- Remove the front panel on the unit Ref. 5 Fig. 10
- Clean the condenser fins Ref. 1 with compressed air (Fig. 8) **DO NOT USE WATER OR SOLVENTS**
- Replace the front panel on the unit Ref. 5 Fig. 10

17.0 TROUBLE-SHOOTING AND EMERGENCY REMEDIES



ALL WORK MUST BE CARRIED OUT BY PROFESSIONALLY TRAINED AND LICENSED PERSONNEL. BEFORE CARRYING OUT ANY MAINTENANCE JOBS IT IS OBLIGATORY TO STOP THE MACHINE AND DISCONNECT IT FROM THE POWER MAINS.

N.B. OPERATIONS MARKED ■ ■ MUST BE CARRIED OUT BY PROFESSIONALLY TRAINED AND LICENSED PERSONNEL APPROVED BY THE MANUFACTURER

FAULT FOUND	POSSIBLE CAUSES	OBSERVATIONS
1) No compressed air passes through the dryer outlet	1A) The pipes are frozen inside	<ul style="list-style-type: none"> ■ ■ -The bypass valve of the hot gas is broken or out-of-calibration -The room temperature is too low and the evaporators piping are obstructed with ice -Clean the filter from the condensate drain ■ ■ -Check the condensate drain
2) Presence of condensate in the pipings.	2A) The condensate separator does not work correctly 2B) The dryer is working outside its rating 2C) The dryer refrigeration condenser is not working properly	<ul style="list-style-type: none"> -Check the flow rate of treated air -Check the room temperature -Check the air temperature at the drier inlet. -Clean the condenser. ■ ■ -Check the operation and the calibration of the press. switch ■ ■ -Check the operation of the fan.
3) The compressor head is very hot (> 55 °C)	Make reference to 2B Make reference to 2C 3A) The cooling circuit is not working with the right gas charge	<ul style="list-style-type: none"> ■ ■ -Check if there are leaks of refrigerating gas. ■ ■ - Charge it again.
4) Motor cuts out on overload	Make reference to 2B Make reference to 2C Make reference to 3A	
5) The motor hums and does not start.	Sequence relays switched on The line voltage is too low. You switched the machine off and on again without leaving enough time for the pressure balancing. The starting system of the motor is defective.	<ul style="list-style-type: none"> - Exchange two phases of main supply -Contact the electric power company -Wait a few minutes before starting the machine again. ■ ■ -Check the running and starting relays and condensers (if any)
6) The machine has stopped and does not restart even after a few minutes.	The thermostatic protection with manual reset has intervened: make reference to 2B-2C-3A. The motor has burnt out.	Contact authorized service provider
7) The compressor is very noisy.	Troubles with the internal mechanical parts	Contact authorized service provider

17.1 REMOTE ALARM FUNCTION

The controller allows to remotely visualize a number of alarms. This is managed by two potential free contact NC (Normally Closed). The contacts opens in case of an alarm.



- **CD contact** : all alarms from the controller (see the section "fault messages"), to the fan motor breaker Q2, to the phase sequency relay KPH and to the safety pressure switch AP. The contact opens when one of the fault happens.

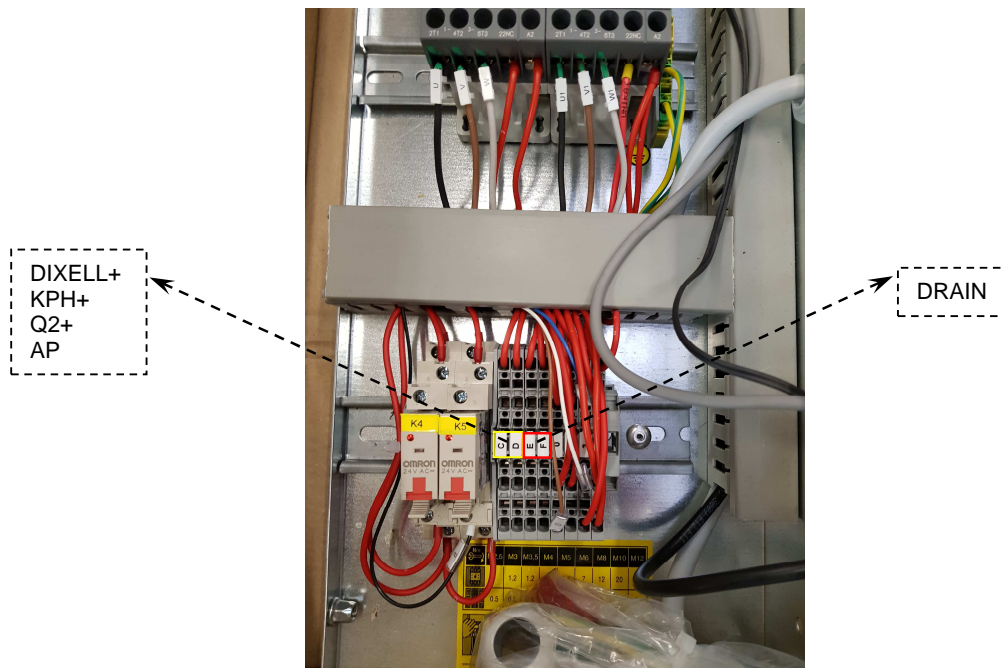



- **EF contact** : alarm coming from the drain. The contact opens when a drain fault occurs.



Free contact location

FAULT MESSAGES

Flashing fault message	Description	Remedy
 84759D	Dewpoint temperature probe failure	Replace the probe
 84865D	Refrigerant compressor discharge temperature probe failure	Replace the probe
 84762D	Pressure dewpoint too high	Refer to the fault and remedies section

Flashing fault message	Description	Remedy
 <p>84765D</p>	Pressure dewpoint too low. Refrigerant compressor shut down	Refer to the fault and remedies section
 <p>84864D</p>	Refrigerant compressor discharge temperature too high; refrigerant compressor stopped.	Refer to the fault and remedies section
 <p>84766D</p>	Internal EPROM error (not remotable)	Reset by pressing one of the four buttons. If the problem persists, replace the controller
 <p>84767D</p>	Maintenance required (not remotable)	Perform the maintenance and reset the alarm

RESETTING THE MAINTENANCE WARNING



Front panel of the controller

To reset the maintenance warning, follow steps 1 to 12:

1. The display is flashing between standard view (dewpoint) and maintenance required (SE) alarm.
2. Push and hold buttons SET (6) and DOWN (8) to enter the menu.
3. Message “SE” appears on display.



4. Push and release the UP button (7).
5. Message “rS” appears on display.



6. Push and release the SET button (6).
7. Message “n” appears on display.



84774D

8. Push and release the UP button (7).
9. Message “y” appears on display.



84776D

10. Push and release SET (6) to reset service alarm.
11. Message “y” blinks for 3 seconds.



84776D

12. Then “rL” is fixed and “°C” blinks on display for about 10 seconds.



84778D

The service alarm is now reset.

SETTING THE SERVICE INTERVAL

To set the service interval, follow steps 1 to 9:

1. PDP is showing standard view.
2. Push and hold buttons SET (6) and DOWN (8) to enter the menu.
3. Message “SE” appears on display.



84770D

4. Push and release SET (6) to enter the “SE” menu.
5. Current service interval is displayed.
 (“60” or any other value between “0” and “99”)



84781D

6. Select desired service interval using the UP and DOWN button.
 (40=4000h, 55=5500h, 80=8000h,...)
7. Push and release SET to confirm the new service interval.
8. The selected value blinks during 3 seconds.



9. Then “rS” is fixed and “C” blinks on display for about 10 seconds.



The new service interval is now set.

FREEZE PROTECTION FUNCTION

Once the digital controller detects a dewpoint temperature below 28,4°F / -2°C during more than 2 minutes, (L2 Alarms), it switches off the refrigerant compressor.

AUTOMATIC CUT OUT OF REFRIGERANT COMPRESSOR

If the refrigerant temperature detected at the inlet of refrigerant compressor exceeds the limit set by manufacturer, the controller stops the refrigerant compressor in order to avoid possible damage.

RESETTING THE DRYER AFTER A REFRIGERANT COMPRESSOR STOP

If a freeze protection or superheating alarm occurs, the controller stops the refrigeration compressor and the dryer must be manually restarted.

Before restarting the dryer, it is necessary to identify the root cause of the problem as such alarms indicate possible issue that may lead to a catastrophic failure. Contact your dealer or the manufacture for technical assistance and support on determining the issue. Restarting the dryer without investigation on possible root cause will affect the reliability of the dryer and may impact the warranty.

Press button Ref. 7 Fig. 9a to reset the alarm.

The dryer restarts when both the following conditions are satisfied:

- The dewpoint temperature is higher than 28.4°F (-2°C)
- 180 seconds are elapsed from the refrigerant compressor stop (minimum balancing pressure stop time).

A countdown is available if the reset is made before the minimum stop time.

SILENT ALARM FUNCTION

To snooze the alarm, press button 5.

REFRIGERANT COMPRESSOR DISCHARGE TEMPERATURE VISUALIZATION FUNCTION

To see the discharge refrigerant compressor temperature, follow steps 1 to 5:

1. PDP is showing standard view.
2. Push and hold buttons SET (6) and DOWN (8) to enter the menu.
3. Push and release the UP button (7) until message “S3” appears on display.



4. Push and release the SET button (7) to enter the "S3" parameter.
5. Current temperature of discharge refrigerant compressor is displayed.



17.2 REMOTE START/STOP FUNCTION

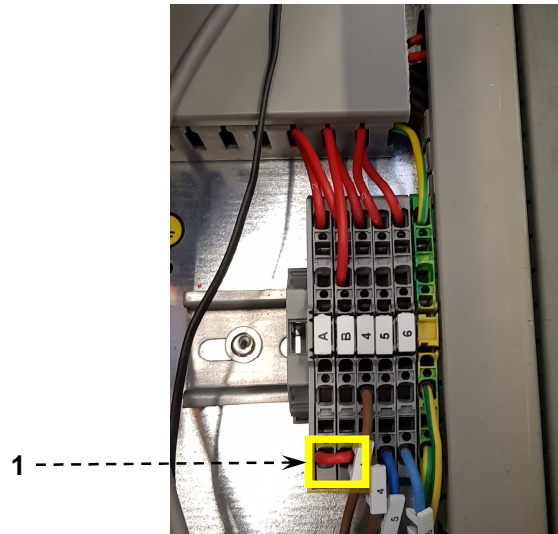

Remove the bridge between A and B and wire a potential free contact in between.
The machine will be remotely controlled by the potential free contact, when the main switch is ON.



Tag clearly that the machine is remotely controlled !



1. Carefully review the electrical diagram before proceeding with any electrical changes
2. The potential free contact **MUST** be tight. A false contact can damage the electrical components
3. Switch off the machine (main switch OFF) before opening the cubicle door
4. The manufacturer does not accept responsibility for damage caused as a result of negligence of failure to abide by the instructions given above.

18.0 STARTING UP



**BEFORE CARRYING OUT ANY OPERATION ON THE MACHINE, ENSURE THAT THE ELECTRIC POWER SUPPLY HAS BEEN DISCONNECTED
WAIT AT LEAST TWO HOURS BEFORE STARTING UP, AFTER ANY MACHINE MOVEMENT (TRANSPORT OR HANDLING).**

18.1 PRELIMINARY CONTROLS

Before starting the dryer, check:

- The correct connection to the compressed air piping: remember to remove protected caps supplied on the drier inlet and outlet.
- The correct connection to the condensate drainage system.
- That the power supply matches the power supply indicated on the dryer nameplate.

18.2 STARTING AND STOP

Start the system before the air compressor starts running and stop it after the air compressor has been stopped. The compressed air piping will be free of condensate only by doing so. The drier must be kept running during all the time the air compressor is running.



IF THE DRYER IS SWITCHED OFF, BEFORE STARTING IT AGAIN, WAIT AT LEAST 5 MINUTES IN ORDER TO ALLOW THE PRESSURE BALANCING.

BEFORE CARRYING OUT ANY MAINTENANCE JOBS IT IS MANDATORY TO STOP THE MACHINE, DISCONNECT IT FROM THE POWER SOURCE AND ISOLATE IT FROM THE COMPRESSED AIR DISTRIBUTION NETWORK.

PRESSURE DISCHARGE PROCEDURE

Proceed as follows:

- Isolate the unit from the compressed air network Ref. 1 Fig. 11
- Release the pressure in the dryer by pressing the condensate drain "TEST" pushbutton located on the drain Ref. 2 Fig. 11
- Switch off the machine. Turn the switch in position STOP Ref. 3 Fig. 11
- Lock-out and tag-out the unit at the fuse/breaker box Ref. 4 Fig. 11

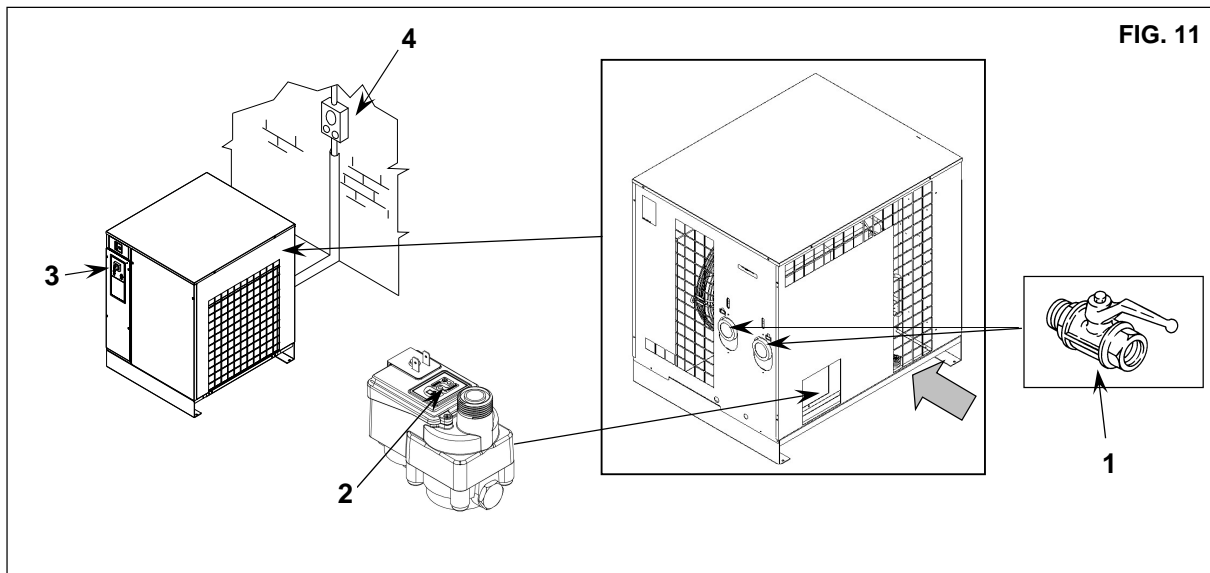

**CALIBRATIONS
BYPASS VALVE FOR HOT GAS**

N.B. These valves have already been calibrated and they do not require any adjustment. An operating dew point that is different from the standard rated performance is typically caused by conditions other than the hot gas bypass valve.

- Ref. 1) Closing cap
- Ref. 2) Adjusting screw

WORKING PRESSURES AND TEMPERATURES OF R410A

	SUCTION SIDE OF REFRIGERATION COMPRESSOR	
	Evaporat. Temperat. °F (°C)	Evaporating Pressure psi (bar)
RATED VALUES AT AMBIENT (Temp. 20°C – 68°F)	23 - 41 (-0,5 - +0,5)	R410A 99,21 – 102,98 (6,84 - 7,10)

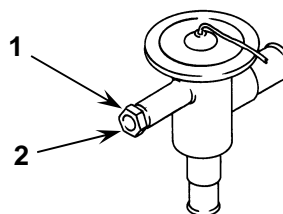



South-Tek Systems
www.southteksystems.com
Tel (888) 526-6284