



# Operation Manual

PRODUCT NAME

## Refrigerated Air Dryer

MODEL / Series

IDFB3E-11□-A,S  
IDFB4E-11□-A,R,T,S,V  
IDFB6E-11□-A,K,R,T,S,V  
IDFB8E-11□-A,K,R,T,S,V  
IDFB11E-11□-A,K,R,T,S,V  
IDFB15E-11□-K,R,T,S,V

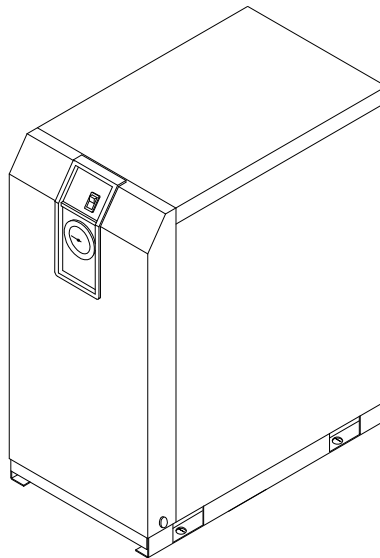

Please read this manual prior of using the air dryer. Keep the manual readily available for reference.

## Dear Customers

Thank you for selecting SMC Refrigerated Air Dryer.

This operation manual must be read and understood thoroughly before using the equipment. It provides all essential information pertaining to safety, as well as, maximizing equipment efficiency in order to extend the life of the equipment.

In addition, it is strongly recommended that you follow all the safety guidelines and regulations set forth by the local government agency for proper installation and usage.

This manual explains about installation and trial operation of the equipment. These tasks should be performed only by individuals with the proper training and have a good understanding of the air dryer.

There is no production amends or financial compensation due to dryers trouble.

This manual contains confidential information proprietary to SMC. It must not be reproduced or disclosed to others, or used in any other way, in part or in whole, except as authorized in writing by SMC.

<p>Caution: Please understand that the contents of this operation manual are subjected to change without prior notice.</p>
--



# Table of Contents

## To Customers

### Chapter i Safety Instructions

<b>i - 1</b>	<b>Warning: Before Using Air Dryer</b> .....	i - 1
i - 1 - 1	Hazard, Warning, and Caution Used in This Manual .....	i - 1
<b>i - 2</b>	<b>Danger Classifications/Position of Hazard warning Label</b> .....	i - 2
i - 2 - 1	Danger Classifications.....	i - 2
i - 2 - 2	Hazard of Electricity .....	i - 3
i - 2 - 3	Hazard of Hot Surface.....	i - 3
i - 2 - 4	Hazard of Rotating Fan Motor .....	i - 3
i - 2 - 5	Danger of Compressed Air Circuit .....	i - 3
i - 2 - 6	Positions of Hazard Warning Label.....	i - 4
i - 2 - 7	Hazard of Refrigerant.....	i - 5
i - 2 - 8	Cautions about Usage.....	i - 6
i - 2 - 9	Other Label .....	i - 6
<b>i - 3</b>	<b>Disposal</b> .....	i - 7

### Chapter 1 Parts Name and Functions

<b>1 - 1</b>	<b>Parts Names and Functions</b> .....	1 - 1
--------------	--	-------

### Chapter 2 Transportation / Installation

<b>2 - 1</b>	<b>Transportation</b> .....	2 - 1
<b>2 - 2</b>	<b>Installation</b> .....	2 - 2
2 - 2 - 1	Location .....	2 - 2
2 - 2 - 2	Tie Down .....	2 - 3
2 - 2 - 3	Air piping .....	2 - 3
2 - 2 - 4	Drain Tube.....	2 - 3
2 - 2 - 5	Electric Wiring diagram.....	2 - 4
<b>2 - 3</b>	<b>Cautions about reinstallation</b> .....	2 - 6

### Chapter 3 Operation / Shutdown

<b>3 - 1</b>	<b>Check points before operation</b> .....	3 - 1
<b>3 - 2</b>	<b>Operation</b> .....	3 - 1
<b>3 - 3</b>	<b>Shutdown</b> .....	3 - 2
<b>3 - 4</b>	<b>Cautions about restart</b> .....	3 - 2
<b>3 - 5</b>	<b>Check points before restart</b> .....	3 - 2

### Chapter 4 Maintenance

<b>4 - 1</b>	<b>Daily inspection</b> .....	4 - 1
<b>4 - 2</b>	<b>Periodical maintenance</b> .....	4 - 1

### Chapter 5 Troubleshooting..... 5 - 1

### Chapter 6 References

<b>6 - 1</b>	<b>Specifications</b> .....	6 - 1
<b>6 - 2</b>	<b>Specifications</b> .....	6 - 1
<b>6 - 3</b>	<b>Dimensions</b> .....	6 - 2
<b>6 - 4</b>	<b>Electric wiring diagram</b> .....	6 - 4
<b>6 - 5</b>	<b>Compressed Air and Refrigerant Circuit / Operation Principles</b> .....	6 - 5
<b>6 - 6</b>	<b>Service Parts List</b> .....	6 - 6

**Chapter 7 Specification for Option A**

- 7 - 1 Safety instructions..... 7 - 1
- 7 - 2 Specification..... 7 - 1
- 7 - 3 Air piping ..... 7 - 1
- 7 - 4 Dryer specifications ..... 7 - 1

**Chapter 8 Specification for Option K**

- 8 - 1 Safety instructions..... 8 - 1
- 8 - 2 Specifications ..... 8 - 2

**Chapter 9 Specification for Option R**

- 9 - 1 Safety instructions..... 9 - 1
- 9 - 2 Specifications of GFCI..... 9 - 2
- 9 - 3 How to connect the power supply ..... 9 - 2

**Chapter 10 Specification for Option S**

- 10 - 1 Safety instructions..... 10 - 1
- 10 - 2 Specifications ..... 10 - 2

**Chapter 11 Specification for Option T**

- 11 - 1 Safety instructions..... 11 - 1
- 11 - 2 Specifications ..... 11 - 1
- 11 - 3 Remote operation..... 11 - 2
- 11 - 4 How to connect the power supply and signal cable..... 11 - 2
- 11 - 5 Electric wiring diagram ..... 11 - 3

**Chapter 12 Specification for Option V**

- 12 - 1 Safety instructions..... 12 - 1
- 12 - 2 Specifications ..... 12 - 1
- 12 - 3 How to perform maintenance ..... 12 - 2

**Chapter 13 Service Record**

- 13 - 1 Service Record..... 13 - 1



## Safety Instructions



Be sure to read and comprehend important cautionary notifications in this operation manual before use



Do not operate the equipment without the cover panel.

### **i-1 Warning: Before Using Air Dryer**

In this chapter, the stated contents are especially about safety.

This Air Dryer is installed downstream of the air compressor to remove moisture. The manufacturer is not responsible for any misuses or misapplications.

This air dryer operates with high voltage and hot surfaces during operation. In addition, this air dryer has high speed rotating fan and motor, which can cause serious injury upon accidental contact. It is advised that you contact the factory or SMC authorized dealer for spare parts or other servicing needs.

We strongly recommend that any one who is working with this air dryer need to read and understand the instructions in this manual beforehand. Often, it's necessary for the people involved, to receive training in order to address the issues of safety and proper application.

When short period power shortage (including instantly recovered shortage) is recovered, it may take a longer starting period than usual starting or may not start due to the protective devices.

In this case, turn off the ON-OFF switch on dryer panel and wait 3 minutes. After this step, turn on the switch to restart. Whenever open the cover panel of this unit, do not miss to turn off the ON-OFF switch, because dryer may start itself when the power supply is recovered.

Connections to a power source where the equipment is exposed to transient stresses exceeding overvoltage category II (as defined in IEC60664-1).

Only connect to TN-S power distribution systems with N conductively connected to PE.

#### **i-1-1 Hazard, Warning, and Caution Used in This Manual**

This equipment is designed with the first priority on safety. However, there are some inherent risks that cannot be eliminated. This manual classifies these risks into the following three categories according to the severity: **DANGER**, **WARNING** and **CAUTION**. Read the warning statements carefully and thoroughly understand them before operating or performing maintenance on the unit.



#### **DANGER**

“DANGER” indicates that there is an imminence hazard that will cause serious injury or death if not avoided.



#### **WARNING**

“WARNING” indicates that there is a hazard that may cause serious injury or death if not avoided.



#### **CAUTION**

“CAUTION” indicates that there is a hazard that may cause minor injury.

## **i-2 Danger Classifications & Position of Hazard warning Labels**

To help you recognize the hazards, the unit utilizes special graphics to indicate different hazards. Confirm the contents of the hazards and the location of the labels before operation.

 <b>Warning</b>
<ul style="list-style-type: none"> <li>• <b>Only properly trained, qualified personnel are allowed to perform tasks such as: Operation, installation, relocation of equipment and maintenance works.</b></li> <li>• <b>Should any problem occurs, address it according to instruction in this manual.</b></li> <li>• <b>Identify problems following the guidelines in Chapter 5 for Troubleshooting before proceed with maintenance works.</b></li> <li>• <b>The equipment should not be turn on in the event of any problems. When the equipment gets out of order, shutdown immediately, and contact for service</b></li> </ul>

### **i-2-1 Danger Classifications**

Specific danger classification of this equipment is as follows.

#### **Hazard of Electricity**

Since this equipment operates with high voltage, there is the danger of electric shock. This special symbol is used, along with key words: **“CAUTION”**, **“WARNING”** or **“DANGER”**, on the equipment and in this manual.



#### **Hazard of Hot Surface**

Since this equipment becomes hot while running, there is the danger of burn injury. This special symbol is used, along with key words: **“CAUTION”**, **“WARNING”** or **“DANGER”**, on the equipment and in this manual.



#### **Hazard of Rotor**

Since this equipment has parts that rotate at high speed while running, there is the danger of bodily injury. This special symbol is used, along with key words: **“CAUTION”**, **“WARNING”** or **“DANGER”**, on the equipment and in this manual.



i-2-2**Hazard of Electricity****Warning**

Inside of this equipment, there is a power-supplying section with high voltage separated by the cover panel. Do not operate the equipment with the cover panel off.

i-2-3**Hazard of Hot Surface****Warning**

Since this equipment has parts that become hot during operation, there is the danger of burn-associated injuries. These parts remain hot even after power is off. Wait until the unit has cooled down before touching.

i-2-4**Hazard of Rotating Fan Motor****Warning**

Since this equipment has parts that rotate during operation, there is the danger of injury resulting from direct contact. The fan and rotor will start/stop automatically. Thus, do not work on them when power is on.

i-2-5**Danger of Compressed Air Circuit****Warning**

Before replacing or cleaning parts, be sure to relief the pressure remained inside of the equipment until the gauge indicates "0". High pressure can propel object at high velocity and cause injury.

## i-2-6 Positions of Danger Warning Label

	<b>Warning</b>
<p>Read with caution and pay attention to the notations of danger warning labels.  Do not remove or rub danger warning labels.  Confirm the positions of danger warning labels.</p>	

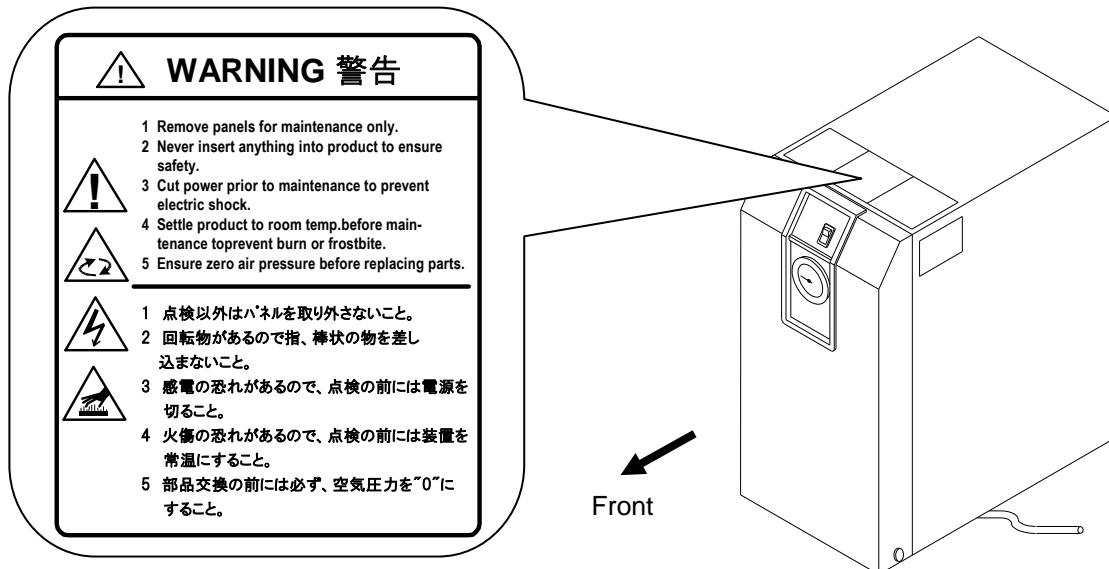



**i-2-7 Hazard of Refrigerant**

 <span style="font-size: 1.2em; font-weight: bold; margin-left: 100px;">Caution</span>
<p><b>This equipment uses Fluorocarbon (HFC) as a refrigerant.</b></p> <p><b>It is strictly forbidden to emit Fluorocarbon into the atmosphere. Before you repair the refrigerant circuit, you should collect the refrigerant with proper evacuation system. The collected refrigerant should be properly recycled by qualified agency. Only personnel with proper credential are allowed to handle refrigerant.</b></p> <p><b>Only properly trained qualified personnel are allowed to remove the cover panel of the equipment.</b></p> <p><b>The quantity and the type of Fluorocarbon are mentioned on the specification label.</b></p>

Front

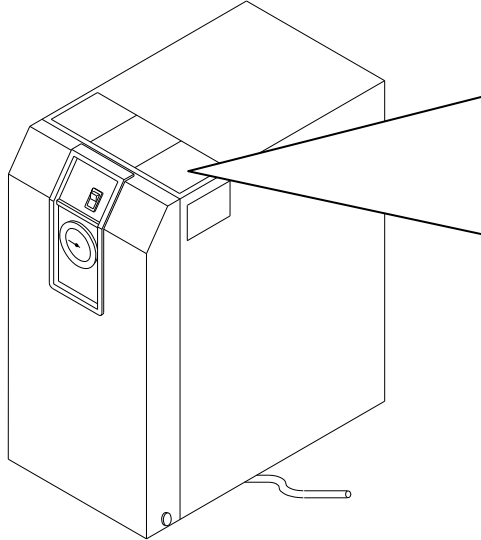

Act for Rationalized Use and Proper Management of Fluorocarbons  
フロン排出抑制法 第一種特定製品

This product uses Fluorocarbon (HFC) as a refrigerant.

- 1 It is prohibited to release fluorocarbons without permission.
- 2 For the disposal of the product, fluorocarbons must first be collected.
- 3 The number and quantity of the refrigerant of the fluorocarbon used for this product is shown on the product label.
- 4 GWP values of the calculated leakage of fluorocarbons to be reported are as in the table below.

この製品には冷媒として、フロン類 (HFC) が使用されています。

- 1 フロン類をみだりに大気中に放出することは禁じられています。
- 2 この製品を廃棄する場合には、フロン類の回収が必要です。
- 3 本製品に使用している、フロン類の冷媒番号、量は、型式銘板に記載されています。
- 4 算定漏えい量の報告に使用する、フロン類のGWP値は以下になります。

Refrigerant No.	R134a	R407C	R410A	R404A
GWP values	1430	1770	2090	3920

**i-2-8 Cautions about Usage**

 <span style="font-weight: bold; font-size: 1.2em;">Warning</span>
<p><b>Please follow the instructions on all warning labels. Do not remove or deface warning labels, and confirm the location of warning labels.</b></p>

 **CAUTION 注意**

---

- 1 Read manual before operation.
- 2 Ensure ventilation and maintenance space.
- 3 Keep water away from the product.
- 4 Secure In / Out connector with spanner during piping.
- 5 Wait 3 minutes before restart.
- 6 Ensure Running Condition / Evaporating Temp. in green zone.

---

- 1 ご使用前に必ず取扱説明書を読んでください。
- 2 通風、メンテナンススペースを確保してください。
- 3 雨や水滴がかからないようにしてください。
- 4 IN/OUTポートをスパナで固定して配管してください。
- 5 再起動は運転停止3分後に行ってください。
- 6 RUNNING CONDITION・蒸発温度計はグリーン帯で使用してください。

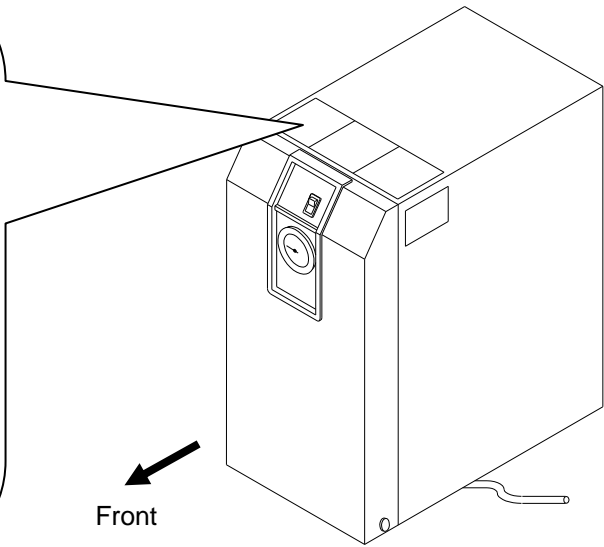

**i-2-9 Other Label**

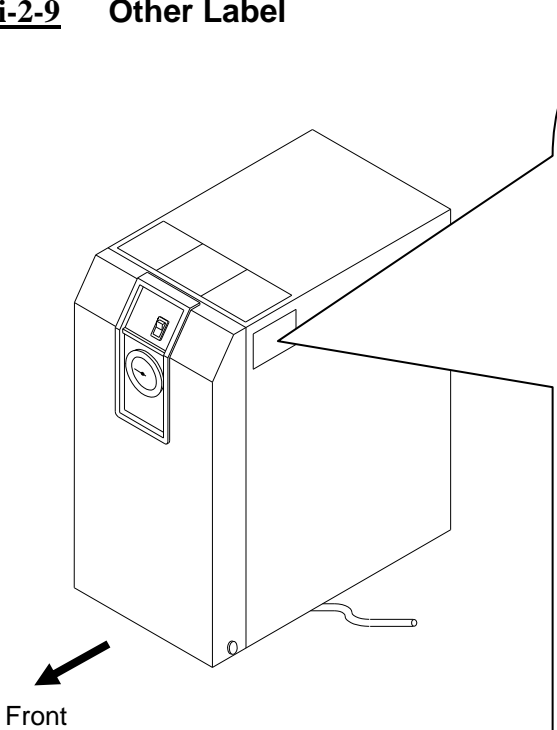

 **SMC**     **AIR DRYER**

---

MODEL  
 VOLTAGE  
 RATED CURRENT  
 MCA  
 MOPD  
 CMP LRA  
 AIR FLOW RATE  
 MAX. INLET PRESS.  
 MAX. INLET TEMP.  
 MAX.AMBIENT TEMP  
 MIN. AMBIENT TEMP  
 REFRIGERANT  
 LO. SIDE PRESS.  
 HI. SIDE PRESS.  
 WEIGHT  
 SERIAL No.  
 MAKER

  
 \*12456789\*

### **i-3 Disposal**

When you dispose of the equipment, you should collect the refrigerant and the refrigerant oil inside the refrigerant circuit.

 <b>Caution</b>
<p><b>This equipment contains Fluorocarbon HFC.</b></p> <p><b>It is strictly forbidden to emit Fluorocarbon into the atmosphere. Before you repair the refrigerant circuit, you should collect the refrigerant with proper evacuation system. The collected refrigerant should be properly recycled by qualified agency. Only personnel with proper credential are allowed to handle refrigerant.</b></p> <p><b>Only properly trained and qualified personnel are allowed to remove the cover panel of the equipment.</b></p> <p><b>The quantity and the type of Fluorocarbon are mentioned on the specification label.</b></p>

 <b>Caution</b>
<p><b>Dispose of the refrigerant and refrigerant oil according to the regulation of local government.</b></p> <p><b>Only personnel with proper credential are allowed to collect refrigerant and refrigerant oil.</b></p> <p><b>Only properly trained and qualified personnel are allowed to remove the cover panel of the equipment.</b></p> <p><b>For any questions, please contact our factory or SMC authorized dealers.</b></p>

# 1 Parts Name and Functions

## 1-1 Parts Name and Functions

- IDFB3E

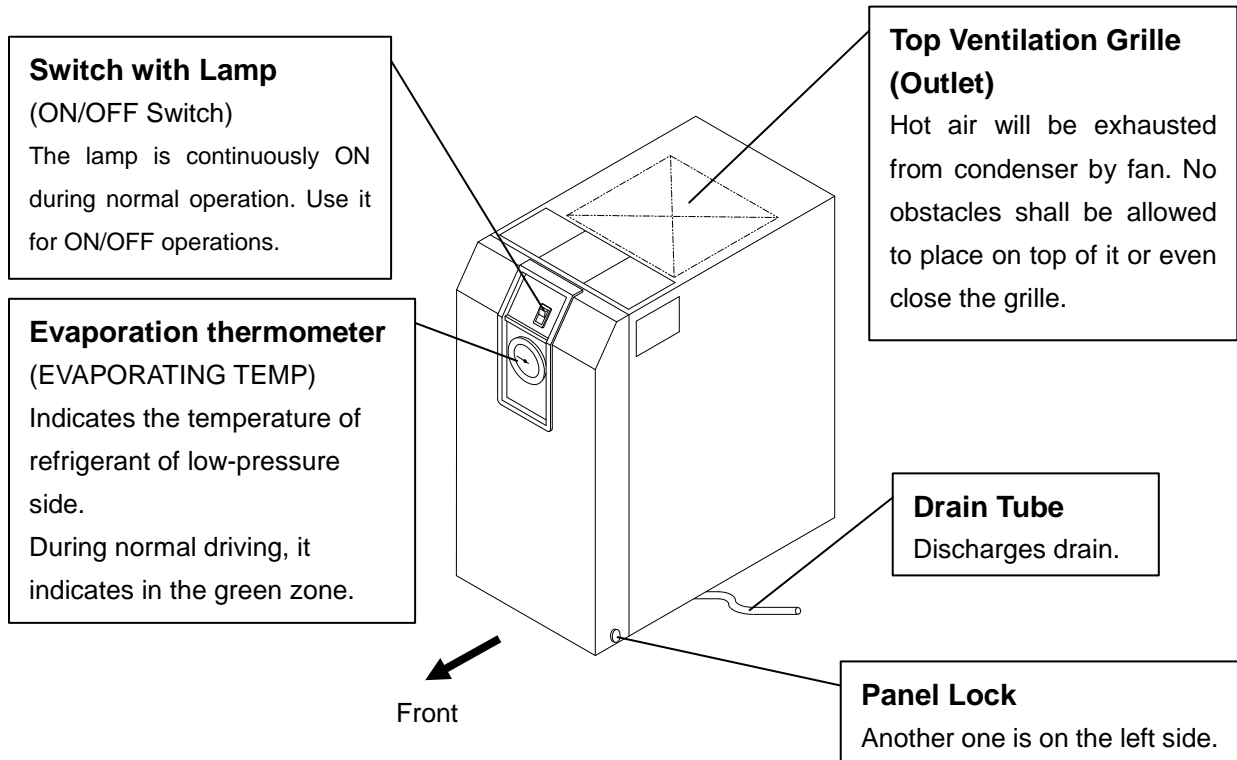

No Front Panel

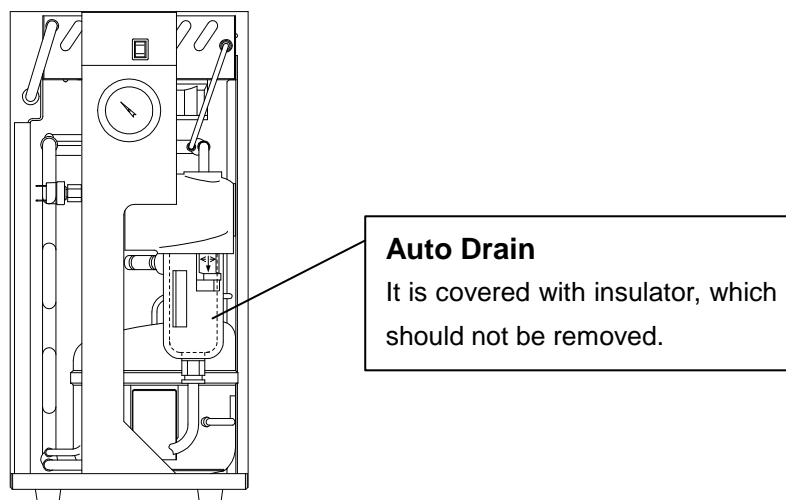

• IDFB3E

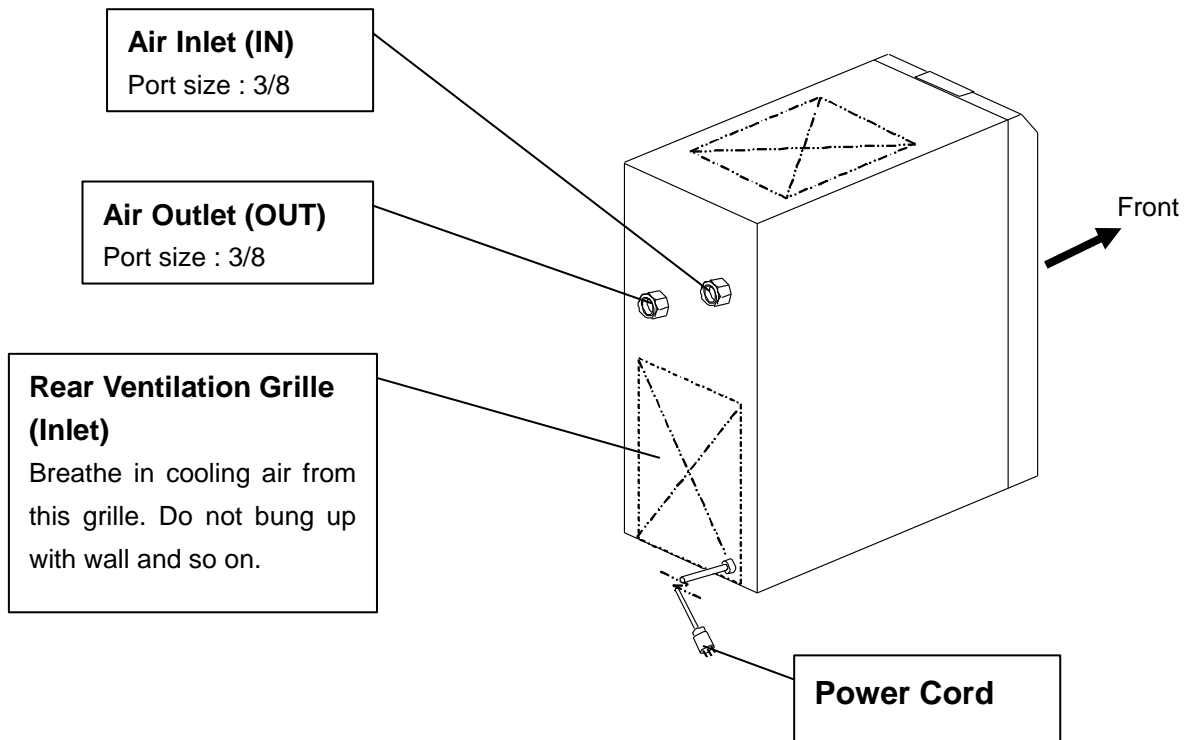

• IDFB4E to 15E

**Switch with Lamp**  
The lamp is continuously ON during normal operation.

**Ventilation Grille**  
Hot air will be exhausted by condenser fan. Do not block these vents.

**Evaporation Thermometer**  
Indicates the evaporating temperature of refrigerant on low-pressure side. During normal operation, the indicator remains in the green zone.

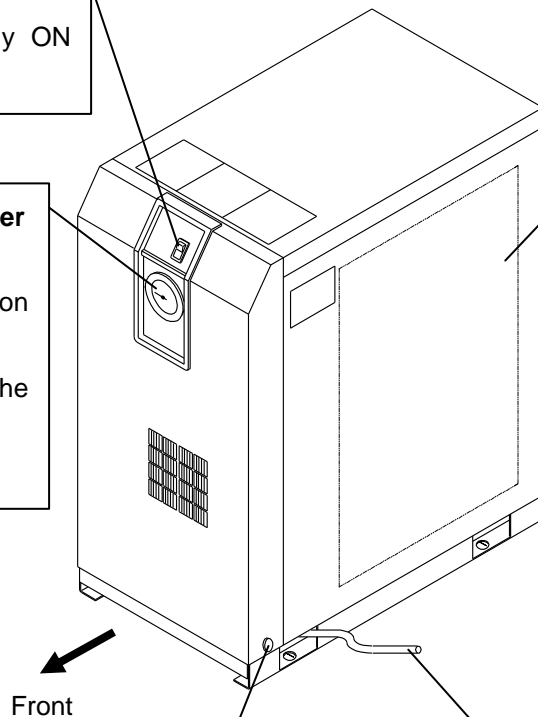

**Panel Set Screw (x 2)**  
Another one is on opposite side

**Drain Tube**  
Discharges drain.

**View with Front Panel removed**

IDFB4E to 11E

IDFB15E

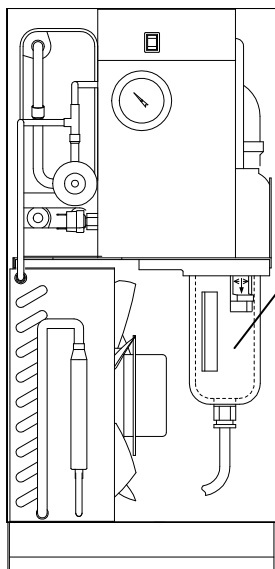

**Auto Drain**  
Do not remove the insulation on the auto drain.

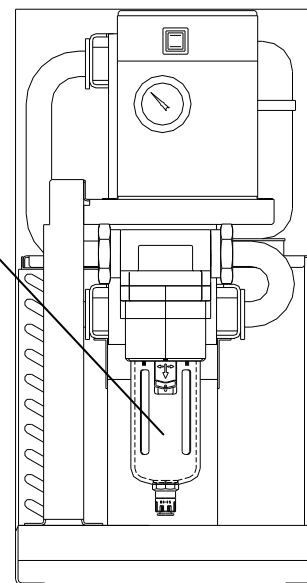

- IDFB4E to 15E

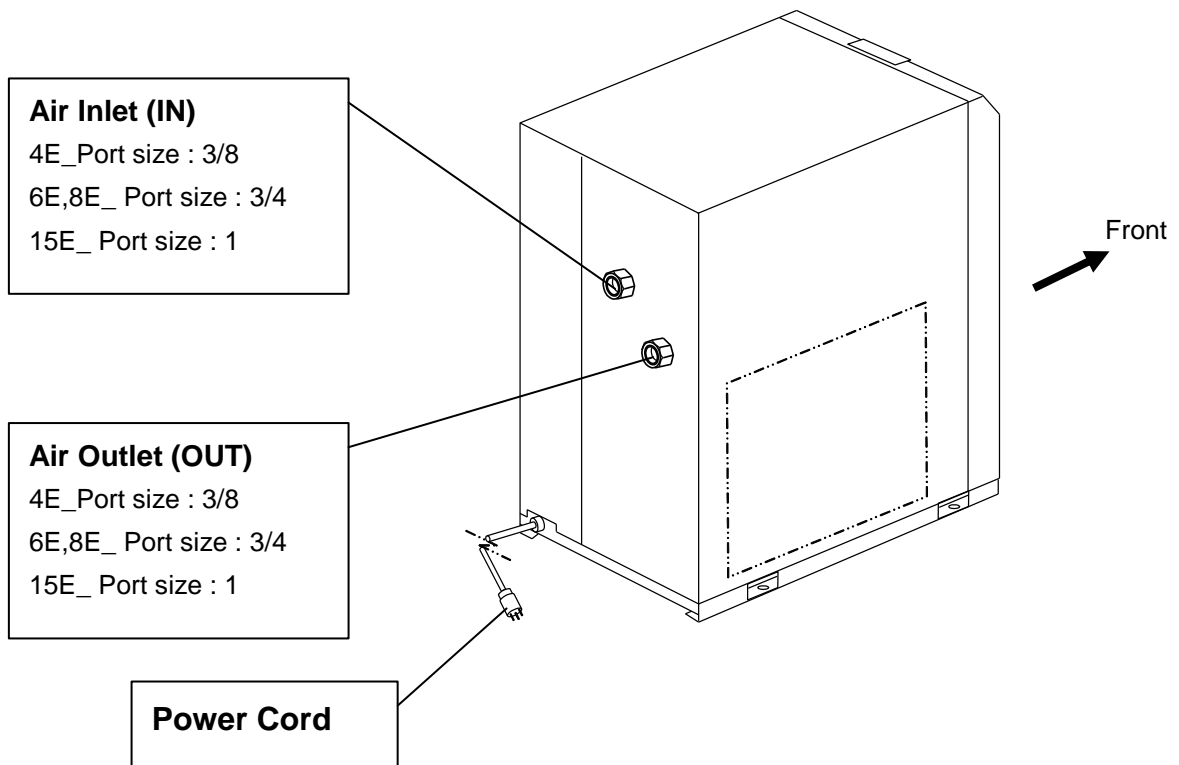

## **2** Transportation/Installation



### **Warning**

- **Only properly trained, qualified personnel are allowed to perform tasks such as: Operation, installation, relocation of equipment and maintenance works.**
- **Strongly recommend to prepare the spare dryer when applying the dryer for important equipment or system.**

### **2-1 Transportation**

When you transport the equipment, you should follow the instructions below:

- You should lift the equipment from the base surface with careful attention to prevent tipping over.
- Do not lay the equipment sideways, or you will damage the equipment.
- Do not suspend the equipment from the ceiling or hang from the wall.



### **Warning**

This equipment is heavy.

Each model IDFB3E to15E weights about 45lbs (20kg) or more. It must be transported by more than one person, a forklift is necessary.



## **2-2 Installation**

### **2-2-1 Location**

**The equipment should not be used or stored in the following conditions: Those conditions will cause not only malfunction but also failures.**

- Environment where the equipment is exposed to rainwater, moisture, salt water or oil.
- Locations where the equipment is exposed to dust or particles
- Locations where the equipment is exposed to flammable, combustible or explosive fumes.
- Locations where the equipment is exposed to corrosive gas or solvent.
- Locations where the equipment is exposed to direct sunlight or radiated heat.
- Locations where ambient temperature is beyond following range:
  - On-stream: 36 to 104 °F (2 to 40°C )
  - Storage: 32 to 122°F (0 to 50 °C )(when there is no drain water inside of the piping)
- Locations where temperature changes rapidly.
- Locations where strong electromagnetic noise is generated.
- Circumstances where static electricity is produced or discharged through the body of the equipment
- Locations where strong high frequency shock wave is generated
- Locations where danger of thunder is apparent.
- Locations where loading on vehicles, marine vessels, and so on
- Locations where altitude is higher than 6666 feet (2,000 meters)
- Circumstances where strong vibration or impact are transmitted.
- Circumstances where too much force and weight are put on the body of the equipment that causes it to deform.
- Circumstances where not enough clearance spaces to do maintenance
  - Spaces needed for maintenance
  - Front : 2feet (0.6m)
  - Rear : 2feet (0.6m)
  - Top : 2feet (0.6m)
  - Right : 2feet (0.6m)
  - Left : 2feet (0.6m)
- Locations where ventilation grille of the equipment can be blocked.
- Locations where the dryer could intake warm air (for example from a compressor or other dryers).

### **2-2-2 Anchorage**

- The air dryer should be installed on a vibration-free, stable, horizontal, flat surface.
- Refer to “Chapter6 6-2 Dimensions” for the dimensions.
- IDFB3E to 15E should be bolted by anchor bolts to prevent falling. We recommend the anchor bolt sets that we are selling separately as accessories.

### **2-2-3 Air piping**

- Connection to the inlet and outlet of compressed air should be made removable by using union and so on.
- Pressing the hexagonal fitting with screw wrench and so on, connect the air piping fittings to the body.
- Prevent the weight of the piping or unreasonable pressure that is caused in the process of piping from loading on the equipment.
- Be careful not to let the vibration of the air compressor transmit.
- If the temperature of compressed air on the inlet side is higher than 122° F (50°C) , place an aftercooler after the air compressor. Or, make the temperature of the place where the air compressor is installed lower than 122° F (50°C) .
- Flush pipes and fittings before connection to prevent dust or chips from entering the air dryer. Those dusts or oil entered in the piping cause incomplete refrigeration and failures of the equipment.
- Use pipes and fittings that have enough endurance against the operating pressure and temperature. And connect it firmly to prevent air leakage.
- Provide bypass piping to make it possible to do maintenance without stopping the air compressor.

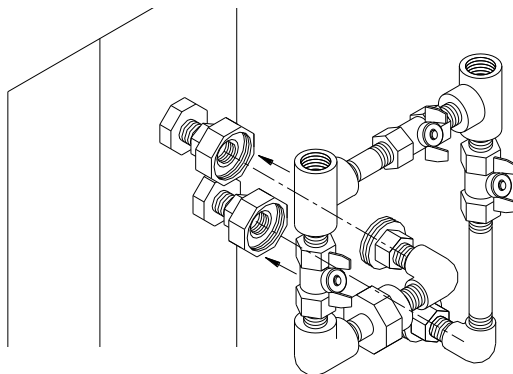

We recommend the bypass piping sets that we are selling separately as accessories.

The bypass piping sets

### **2-2-4 Drain Tube**

- A polyurethane tube is attached to the auto drain. The end of the tube is open to atmosphere to let drain flow through the tube into a collector or drain pipe.
- The compressed air is used to push out the drain periodically. Fix the outlet end of the tube in order to prevent whipping action during discharge.
- Install the drain tube in such a way so that no drain is trapped.
- During installation, make sure the dryer does not sit on the drain tube which is at the bottom of the unit. Be careful to avoid the dryer from crushing the tube during installation.

**Warning**

**To handle drain discharge, follow the safety guidelines such as wearing protective goggles, apron, and gloves.**

In case that oil gets mixed in the wastewater discharged from the auto drain, the liquid would be considered as toxic waste and treatment is necessary in accordance with local regulations.

**2-2-5 Electric Wiring****Warning**

- **Only properly trained and qualified personnel are allowed to perform wiring work.**
- **Before wiring, you must disconnect the power. Do not work under any energized conditions.**
- **Supply power from a stable source that is free from the effect of surge.**
- **Referring to “6-1 Specifications,” make sure to install a GFCI breaker that has the right short circuit capacity and load capacity.**
- **Supply power of the equipment should meet the specifications on page 6-1.**
- **The equipment must be grounded for safety.**
- **Do not connect ground wire to a water pipe, a gas pipe, or a lightning rod.**
- **Do not plug too many leads into a single socket.**
- **Circuit breaker must be properly selected to meet safety standard of local regulations.**
- **Always be sure to connect the protective conductor first, disconnect it last in respect to the other connections.**
- **Be sure that the protective conductor has some additional length in respect to the live conductors, so that it is not subject to mechanical stresses.**
- **Be sure to install the circuit breaker correctly so that it disconnects all live conductors and so that the operating handle can be easily accessible.**

**Specification of power cable**

Prepare following power cable.

Power cable: 16AWG (1.25~1.5mm<sup>2</sup>) , Three-cores (including the ground cable)

Additional length of about 4inch (0.1m) is needed to wire inside of the equipment.

**Length of the power cable**

The maximum length of the power cable should be no more than 98feet (30m).

**Connecting to the power supply**

- Connect the power cable and the ground to the terminal block

**Wiring procedure**

- 1.Remove the terminal block cover or the rear panel.
- 2.Insert the cable through the rubber grommet and connect it to the terminal block (refer to the label on the terminal block).

During wiring work, do not touch other sections except terminal block.

- 3.Insert the screwdriver into terminal block and open spring of terminal.

(The cable insulator must be stripped at 3/8inch (10mm).)

- 4.Insert the cable and remove the screwdriver.
- 5.Re-attach the cover or real panel after wiring is done.

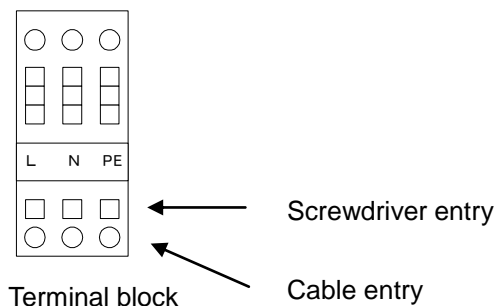

118 to 138 mil  
(3 to 3.5mm)

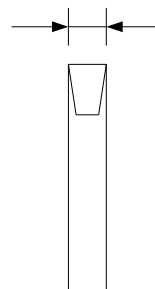

Applicable screwdriver

## **2-3 Cautions for Reinstallation**

	<b>Caution</b>
<b>Only properly trained, qualified personnel are allowed to perform reinstallation.</b>	

If the equipment is moved and reinstalled in another place after some trial operations, the following instructions must be followed as well as procedures in Chapter 2.

### **Removing the power cable**

**Disconnect the power source before removing the power cable.**

	<b>Warning</b>
<b>Only properly trained, qualified personnel are allowed to perform wiring. Disconnect the power source before wiring. Do not work under energized condition</b>	

### **Disconnecting air pipes**

	<b>Warning</b>
<b>Only properly trained, qualified personnel are allowed to perform piping works. Separate the compressor from the equipment before disconnecting the air pipe. Do not disconnect any piping when there is residual air pressure inside of the pipe.</b>	

Remove the seal tape completely after removing the piping. Loose seal tape can clog up the system.

### **Releasing residual pressure**

Bypass valve should open even after the dryer has been removed.

Close the compressed air inlet and outlet valve.

Unscrew the front panel screws (in 2 places) and remove the front panel.

Open the auto drain residual pressure release valve to release air pressure inside the equipment. Refer to the method of cleaning the auto drain strainer in "Chapter 4 Maintenance" for detail.

## 3 Operation/Shutdown



### Caution

Only properly trained and qualified personnel are allowed to perform operation/shutdown of the equipment.

### 3-1 Check points before operation

Before trial run, check the following points:

- Installed Conditions:  
By visual inspection , check that the equipment is level.  
Model IDFB3E to 15E, make sure the equipment is tied down with anchor bolts.  
Do not place heavy objects on the top of the equipment. Make sure piping does not add weight to the equipment.
- Power cord, and the ground should be connected firmly.
- Drain tube should be connected correctly.
- Make sure the piping for compressed air is connected correctly.

### 3-2 Operation

Start operation according to the procedure below.

- Turn on the breaker of the main power supply. Then, turn on the illuminated ON/OFF switch.
- The lamp will light up. Few minutes later, the cooling fan will rotate and hot air will be exhausted from the ventilation grille.  
Location of the ventilation grille: Model: IDFB3E: The upper surface Ventilation Grille  
IDFB4E to 15E: Right Side Ventilation Grille
- Open the IN/Out side valve slowly. Make sure the bypass valve is completely closed. Confirm there is no air leaks.
- Depending on the condition of compressed air or ambient temperature, the cooling fan sometimes alternates between start/stop at the beginning. Then, the refrigerant compressor will start and the pointer of the evaporating temperature will indicate in the green zone. If the pointer indicates higher than the green zone, refer to “Chapter 5 Troubleshooting.”
- After running for a while, moisture will be discharging from the drain tube automatically.



### Caution

**Avoid frequent On/Off operation, which may cause problems.**  
The auto drain used for the equipment has a structure that closes the valve with air pressure higher than 22psi(0.15MPa). Therefore, until the pressure increase, air will be emitting from the drain outlet at the start of opening the “IN” valve. Keep in mind that sometimes the pressure cannot increase due to under-sized air compressor.

### **3-3 Shutdown**

- Turn off the ON/OFF switch.
- The lamp will go out and then, the operation will stop. Depending on the condition of operation, hot air continues to be emitted from the ventilation grille by the cooling fan for a while after turning off the switch.

### **3-4 Cautions about restart**

- Wait at least 3 minutes before restarting the air dryer after it has been shut down. Failure to do this may cause safety devices to trip due to over load.

### **3-5 Check points before restart**

Check following points before you start operation. If any abnormalities occur, immediately stop the operation.

Turn off the ON/OFF switch follow by the breaker of the main power supply.

- There is no air leaks.
- Air pressure, temperature, flow rate, and ambient temperature meet the specifications.
- Moisture is being discharged from the drain tube.
- The pointer of evaporating temperature indicates in the green zone.
- There are no abnormal sound, vibration, or odor.

## 4

## Maintenance

**4-1 Daily Inspection**

Check following points during normal operations. If you find some problems, immediately stop the dryer and refer to “Chapter 5 Troubleshooting” as soon as possible.

- There is no air leaks.
- The running lamp is on during operation
- Moisture is being discharged from drain tube
- The pointer of the evaporating temperature indicates in the green zone
- The pointer of the evaporating temperature indicates about 41 to 59° F(5 to15°C) lower than that of the ambient temperature when compressed air stops supplying to the air dryer.
- There is no abnormal odor or smoke coming from the equipment.
- It is recommended to keep a maintenance/service record. Please refer to “Chapter 12-1 Service Record”

**4-2 Periodical Maintenance**

As a preventive maintenance, clean following parts periodically.

- Auto Drain Strainer Once a month; \*Note

\* Note: If they are too dirty, replace them and shorten the period of maintenance for next time.

Part No.	Name	Quantity	Applicable Model
IDF-S0001	Auto Drain Strainer	1	IDFB3E,IDFB4E
IDF-S0002	Auto Drain Strainer	1	IDFB6E,IDFB8E, IDFB11E,IDFB15E

Clean dust and other foreign particles from the ventilation area with vacuum cleaner or air blow nozzle once a month. During air blowing, wear protective goggles and masks.

**Cleaning of Auto Drain Strainer****Danger**

**Do not remove the case assembly when there is still air pressure left inside the equipment. Air pressure can propel the casing at high speed when unscrew it from the body. Put on gloves to prevent injury when remove the case assembly.**

**Danger**

**Do not remove the auto drain strainer during operation. There is a power terminal section nearby that can expose you to high temperature and high voltage.**



**Danger**

Since this equipment has parts that become hot during operation, there is the danger of burn-associated injuries. These parts remain hot even after power is off. Wait until the unit has cooled down before touching.

**Danger**

There is the risk of touching discharged drain fluid during replacement. Wear protective goggles, aprons, and gloves to prevent direct contact.

**Danger**

Use aqueous solution of neutral detergent to clean. Do not use solvent such as thinner.

**Danger**

Switch the unit power supply "off" to ensure that cooling fan will not start, before removing front panel to gain access the auto drain.

**Note**

In case that oil get mixed in the drain discharged from the auto drain, the wastewater treatment is needed. Follow the regulations of local government.

- Turn off the illuminated ON/OFF switch
- Fully close the IN / OUT valves. For safety, only close the bypass when you need compressed air. Otherwise keep it opened.

**1. How to remove the Front Panel**

Unscrew the Panel Lock (2 places) on both sides of the front panel.

Do not use excessive force to remove front panel

**2. How to remove the Auto Drain Strainer**

- ① Remove the drain tube.
- ② Open the residual pressure release valve, and release air pressure inside the equipment.
- ③ Prepare a vessel to catch drain water that will push out because of air pressure left inside of the equipment.

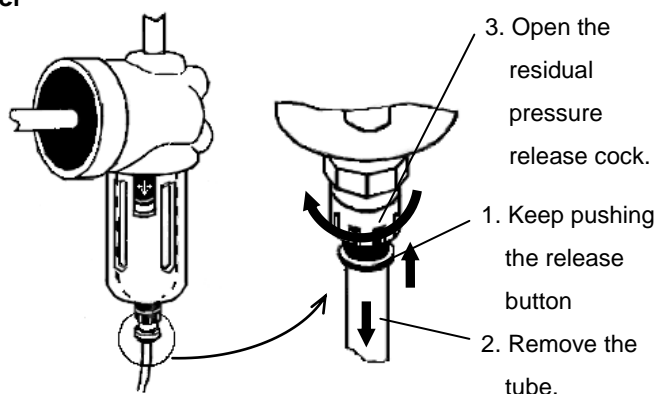

- ④ Grip the case assembly lightly and pull down the lock button with thumb. Then, directly turn the case assembly left (or right) to match the marks. Remove thumb from the lock button and pull the case assembly down slowly (vertically) to remove the case assembly.

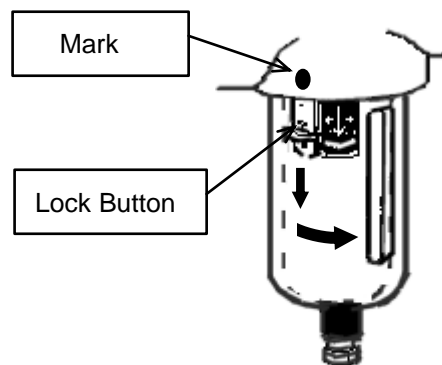

- ⑤ Remove the auto drain strainer and clean it. Pay attention to sharp edges of the strainer to avoid cuts.

- ⑥ Put aqueous solution of neutral detergent into the case assembly and shake it to clean.

- ⑦ Check case "O" Ring for damage such as: scarring, twist, deformation, or foreign matters adhering to it. Then, apply grease thinly and fit it in the gap of the case assembly.

- ⑧ Load the auto drain strainer to the case assembly and fit it with the body of the auto drain. Turn it until it clicks in place.

- ⑨ As a safety check to make sure the casing is secured in place, try to turn the case assembly lightly to confirm whether it cannot be turned. If it can be turned, try to re-attach the casing again until it snap in place.

- ⑩ Close the residual pressure release cock and re-attach the drain tube and front panel as they were.

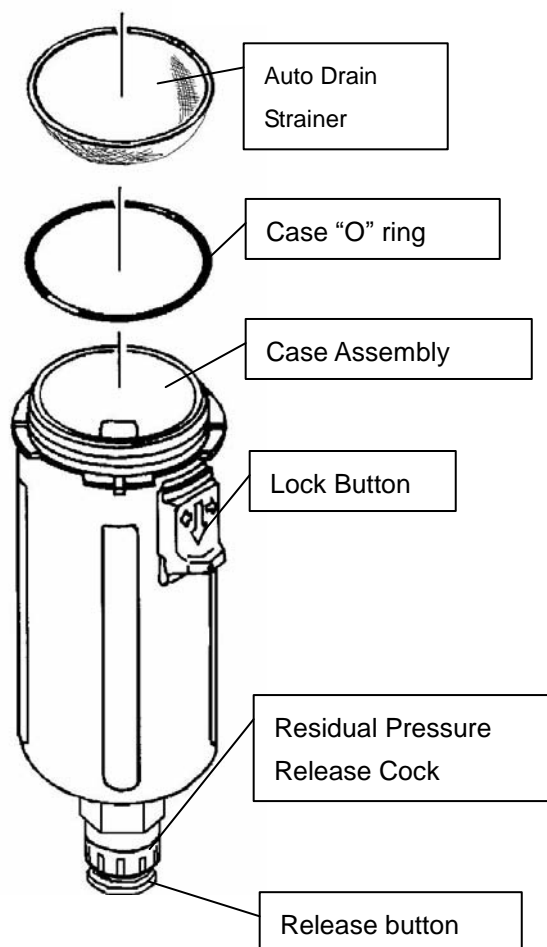

## 5

## Troubleshooting

Should any problem occur, inspect the following table, and if the problem cannot be solved, shut off the power supply and then contact one of our sales offices for further instructions.

<b>Problem</b>	<b>Probable Causes</b>	<b>Remedy</b>
Air dryer does not operate and run lamp does not light on, when the switch is ON.	Power cord or plug is loose or not connected to the power source.	Perform proper connection on the power cord and plug.
	Circuit breaker is OFF.	Confirm whether the proper capacity of the circuit breaker is used. It is not possible to restart the air dryer within 3 minutes after shutdown. Wait for 3 minutes before restarting. Resume the operation after resetting the circuit breaker to ON. If the circuit breaker still trip to OFF, failure of electrical insulation may have occurred. Remove the power supply and contact the factory for further instructions.
Running lamp extinguishes and compressor stops during operation but resumes normal operation illuminating the lamp after a period of time.	Installation place is poorly ventilated. Ambient temperature is too high.	Improve the ventilation system to lower the ambient temperature.
	The ventilation grilles are obstructed by wall or clogged with dust.	Install the air dryer more than 2feet (0.6m) away from the wall.Clean the ventilation grilles once a month.
	Temperature of the Compressed air is too high.	Improve the ventilation system around air or make ambient temperature low. Reduce the temperature of the compressed air by installing an additional aftercooler before the air dryer.
	Supply voltage is not in the following range:	Set the voltage to a proper value by installing a transformer or review the electrical wiring.
Evaporation thermometer indicates higher than green zone.	Installation place is poorly ventilated. Ambient temperature is too high.	Improve the ventilation system to lower the ambient temperature.
	The ventilation grilles are obstructed by wall or clogged with dust.	Install the air dryer more than 2feet (0.6m) away from the wall.Clean the ventilation grilles once a month.
	Temperature of the compressed air is too high.	Improve the ventilation system around the air compressor or make ambient temperature around the air compressor low to lower the temperature of discharge from compressor. Reduce the temperature of the compressed air by installing an additional after-cooler after the air dryer.
Moisture occurs downstream of the compressed air lines.	Bypass valve of air dryer is not fully closed.	Close the valve completely.
	Drain is not discharged from auto drain properly.	Check if the drainpipe has fluid trap or bent. Check auto drain. Check auto drain strainer.
	Moisture from separate air circuit that is without air dryer.	Install additional air dryer on the line that does not have one. Separate two lines not to converge.
Large pressure drop	IN/OUT valve on the air dryer side is not fully opened.	Open IN/OUT valve fully.
	Filter that is installed separately in compressed air line is clogged.	Replace the filter element. (Follow the instruction manual of each individual device.)

## 6

## References

**6-1 Specifications**

Specification		Model	IDFB3E	IDFB4E	IDFB6E	IDFB8E	IDFB11E	IDFB15E
Air Flow Rate (ANR) (Note1)	At Expected Outlet Press.Dew Point of 37° F (2.8°C)		10 SCFM (17 m <sup>3</sup> /h)	15 SCFM (25 m <sup>3</sup> /h)	25 SCFM (43 m <sup>3</sup> /h)	41 SCFM (70 m <sup>3</sup> /h)	59 SCFM (100 m <sup>3</sup> /h)	71 SCFM (120 m <sup>3</sup> /h)
	At Expected Outlet Press.Dew Point of 45° F (7.2°C)		11 SCFM (19 m <sup>3</sup> /h)	16 SCFM (27 m <sup>3</sup> /h)	26 SCFM (45 m <sup>3</sup> /h)	43 SCFM (74 m <sup>3</sup> /h)	62 SCFM (106 m <sup>3</sup> /h)	80 SCFM (136 m <sup>3</sup> /h)
	At Expected Outlet Press.Dew Point of 50° F (10°C)		12 SCFM (20 m <sup>3</sup> /h)	17 SCFM (28 m <sup>3</sup> /h)	28 SCFM (47 m <sup>3</sup> /h)	45 SCFM (77 m <sup>3</sup> /h)	65 SCFM (110 m <sup>3</sup> /h)	86 SCFM (147 m <sup>3</sup> /h)
Rated Condition	Operating Pressure	100psig (0.7MPa)						
	Inlet Air Temperature	100° F (37.8°C)						
	Ambient Temperature	100° F (37.8°C)						
	Voltage	115V 60Hz						
Operating Range	Working Fluid	Compressed Air						
	Inlet Air Temperature	41-122° F (5-50°C)						
	MIN. Inlet Air Pressure	22psig (0.15MPa)						
	MAX. Inlet Air Pressure	150psig (1.0MPa)						
	Ambient Temperature	36-104° F (2-40°C) Relative Humidity of 85% or less						
Electrical Specification	Power source	1 ϕ AC115V±10% 60Hz (Note3)						
	Starting Current and LRA (Note2)	11A	13A	16A	35A	33A		
	Operating current (Note2)	2.7A	3.0A	3.5A	6.5A	7.5A		
	Power consumption (Note2)	240W	260W	310W	550W	750W		
	GFCI Breaker	Reted Current 15A:Sensivity 30mA						
Condenser	forced air cooling							
Refrigerant	R134a (HFC)							
Refrigerant Charge Quantity		6.3±0.2oz (180±5g)	7.1±0.2oz (200±5g)	8.1±0.2oz (230±5g)	9.5±0.2oz (270±5g)	10.2±0.2oz (290±5g)	12.0±0.2oz (340±5g)	
Thread Type and Size	Thread Symbol "N" (female)	NPT3/8	NPT1/2	NPT3/4			NPT1	
	Thread Symbol "None" With Adapter	Rc3/8	Rc1/2	Rc3/4			Rc1	
Drain Tube	Thread Symbol "N"	3/8inch						
	Thread Symbol "None"	10mm						
Painting Finish	baking finish							
Color	Panel:Urbanwhite1							
Weight		40lbs (18kg)	55lbs (25kg)	57lbs (26kg)	64lbs (29kg)	73lbs (33kg)	110lbs (50kg)	

Note1: The data for SCFM (ANR) is referring to the conditions of 68° F (20°C), 1atm . pressure & relative humidity of 65%.

Note 2: The value is that of under specified condition.

Note 3: When short period power shortage (including instantly recovered shortage) is recovered, it may take a longer starting period than usual starting or may not start due to the protective devices.

**6-2 Refrigerant with GWP reference**

Refrigerant	Global Warming Potential (GWP)	
	Regulation (EU) No 517/2014 (Based on the IPCC AR4)	Revised Fluorocarbons Recovery and Destruction Law (Japanese law)
R134a	1,430	1,430
R404A	3,922	3,920
R407C	1,774	1,770
R410A	2,088	2,090

Note:

1. This product is hermetically sealed and contains fluorinated greenhouse gases.
2. See specification table for refrigerant used in the product.

### 6-3 Dimensions

• IDFB3E-11

Table1. Thread symbol

SYMBOL	DRAIN TUBE SIZE
NONE	10mm
N	3/8

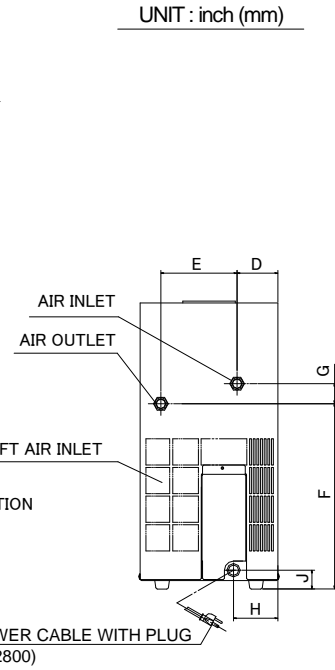
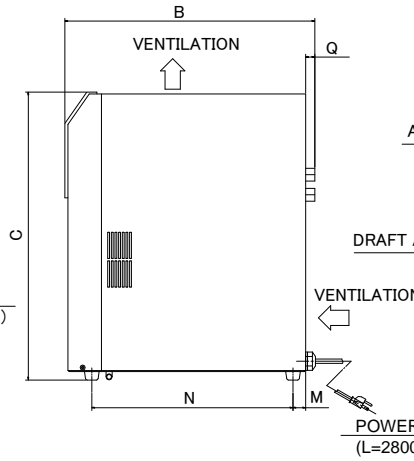
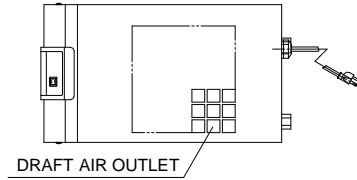
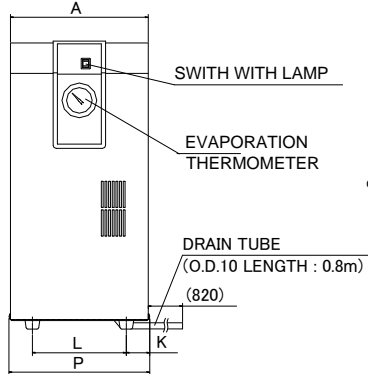

UNIT : inch (mm)

• IDFB4E/6E/8E/11E-11

Table1. Thread symbol

SYMBOL	DRAIN TUBE SIZE
NONE	10mm
N	3/8

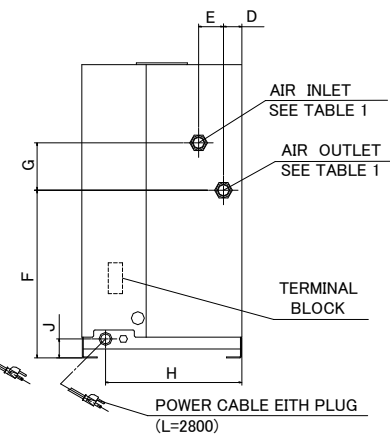
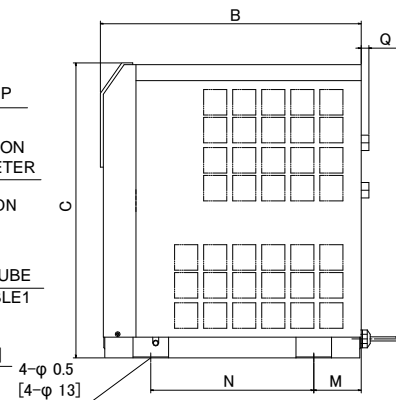
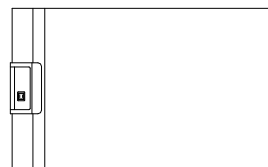
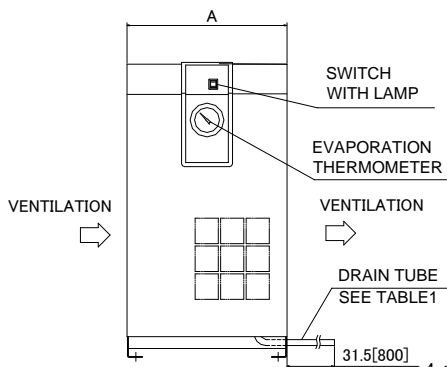

UNIT : inch (mm)

• IDFB15E-11

Table1. Thread symbol

SYMBOL	DRAIN TUBE SIZE
NONE	10mm
N	3/8

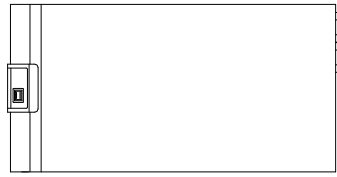

UNIT : inch (mm)

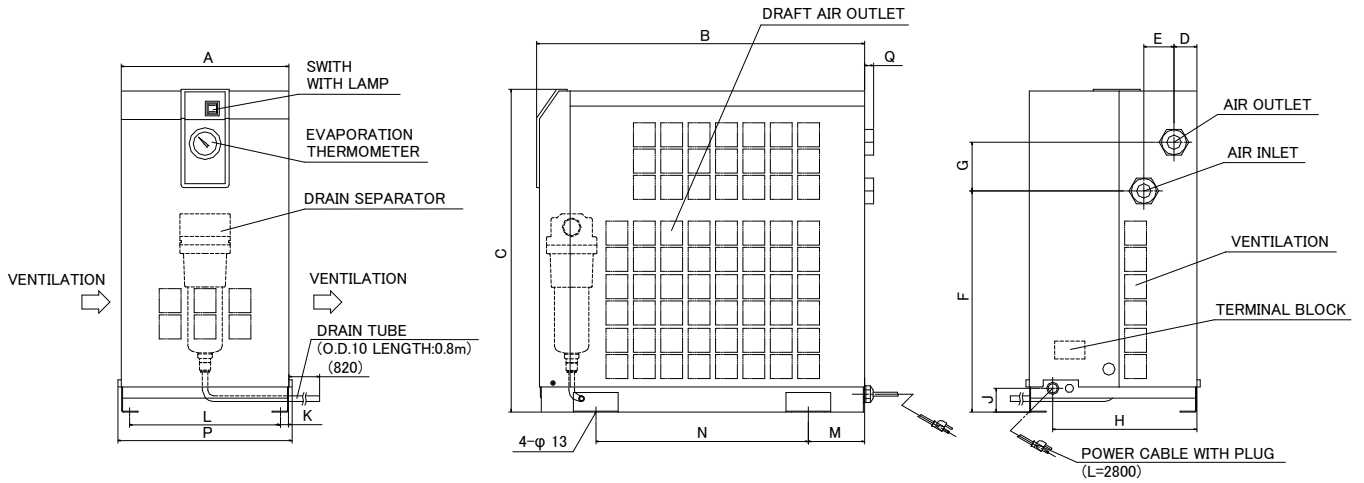

Model	Thread Size	Dimensions (inch[mm])															
		A	B	C	D	E	F	G	H	J	K	L	M	N	P	Q	
IDFB3E	3/8	8.9 [226]	16.1 [410]	186 [473]	26 [67]	4.9 [125]	120 [304]	1.3 [33]	2.9 [73]	1.2 [31]	1.4 [36]	6.1 [154]	0.8 [21]	130 [330]	9.1 [231]	0.6 [15]	
IDFB4E	1/2	10.6 [270]	17.8 [453]	17.8 [453]	1.2 [31]	1.7 [42]	11.1 [283]	3.1 [80]	9.1 [230]	1.3 [32]	0.6 [15]	9.4 [240]	3.1 [80]	10.8 [275]	10.8 [275]	0.5 [13]	
IDFB6E	3/4		17.9 [455]	22.4 [568]			14.0 [355]							11.8 [300]		0.6 [15]	
IDFB8E			19.1 [485]				14.0 [355]									11.8 [300]	0.6 [15]
IDFB11E			11.8 [300]														
IDFB15E	1	11.8 [300]	23.7 [603]	22.8 [578]	1.6 [41]	2.1 [54]	16.6 [396]	3.4 [87]	10.2 [258]	1.7 [43]	0.6 [15]	10.6 [270]	4.0 [101]	15 [380]	12.4 [314]	0.6 [16]	

### 6-4 Electrical wiring diagram

#### IDFB3E

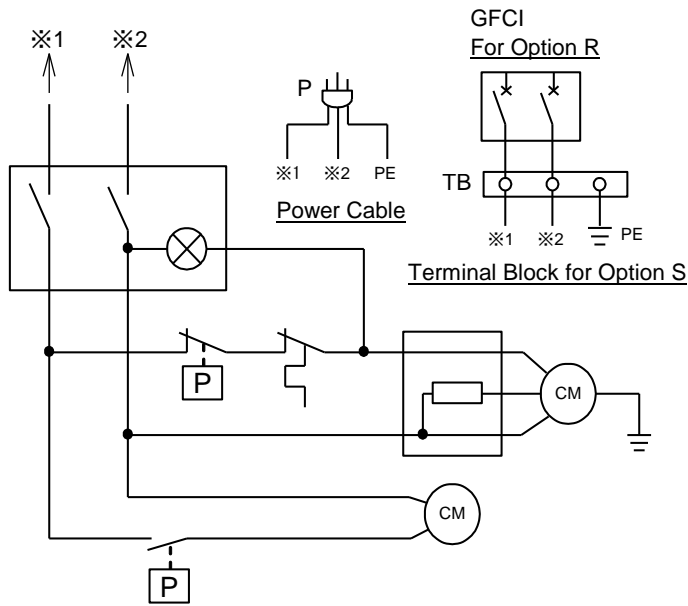

SYMBOL	DESCRIPTION
CM	Compressor Motor
FM	Fan Motor
OLR	Overload Relay (Inside of compressor terminal cover)
PTC	PTC Starter
ILS	Switch with Lamp
PRS	Pressure Switch
TB	Terminal Block

#### IDFB4E / 6E / 8E

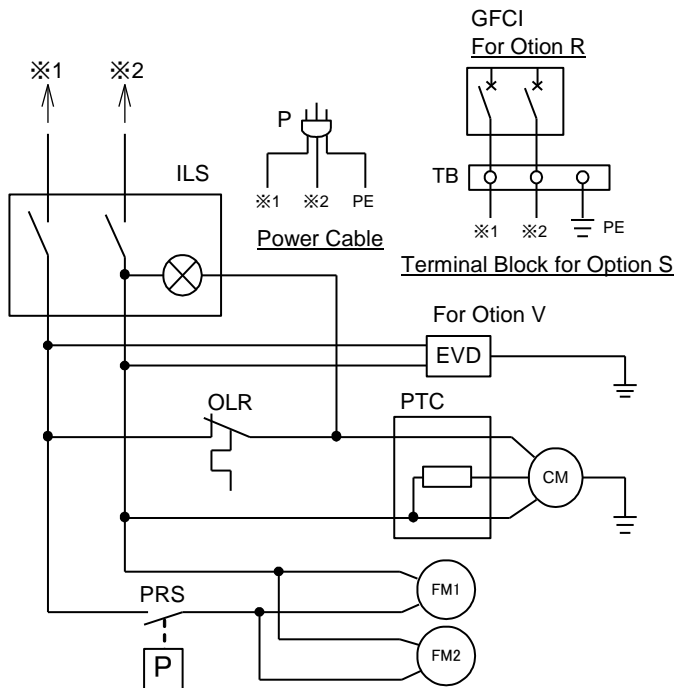

SYMBOL	DESCRIPTION
CM	Compressor Motor
FM1~2	Fan Motor
OLR	Overload Relay (Inside of compressor terminal cover)
PTC	PTC Starter
ILS	Switch with Lamp
PRS	Pressure Switch
TB	Terminal Block
GFCI	Ground Fault Circuit Interrupter
EDV	Electronic Drain Valve

IDFB11E

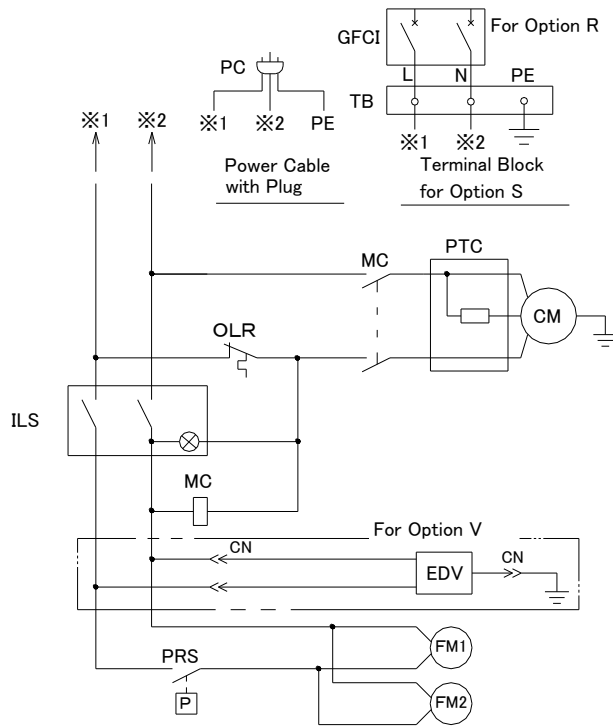

SYMBOL	DESCRIPTION
CM	Compressor Motor
FM1~2	Fan Motor
OLR	Overload Relay (Inside of compressor terminal cover)
ILS	Switch with Lamp
PRS	Pressure Switch
TB	Terminal Block
MC	Magnetic Contactor
GFCI	Ground Fault Circuit Interrupter
EDV	Electronic Drain Valve
PC	Power Cable

IDFB15E

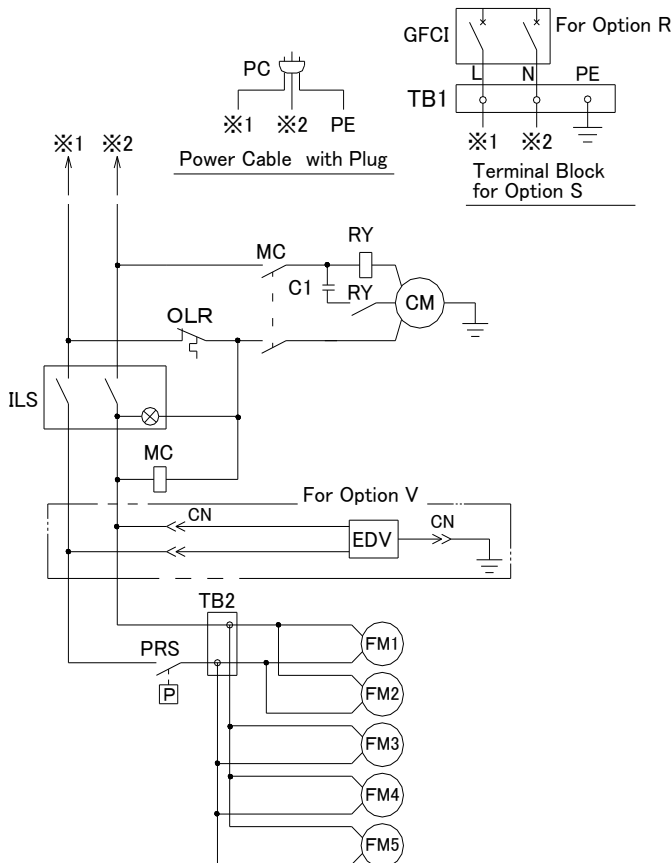

SYMBOL	DESCRIPTION
CM	Compressor Motor
FM1~5	Fan Motor
OLR	Overload Relay (Inside of compressor terminal cover)
C1	Capacitor For Compressor Motor
ILS	Switch with Lamp
PRS	Pressure Switch
TB1~2	Terminal Block
RY	Starting Relay
MC	Magnetic Contactor
GFCI	Ground Fault Circuit Interrupter
EDV	Electronic Drain Valve
PC	Power Cable



**6-5 Compressed Air and Refrigerant Circuit/Operation Principles (BASIC MODEL)**

**IDFB3E-11**

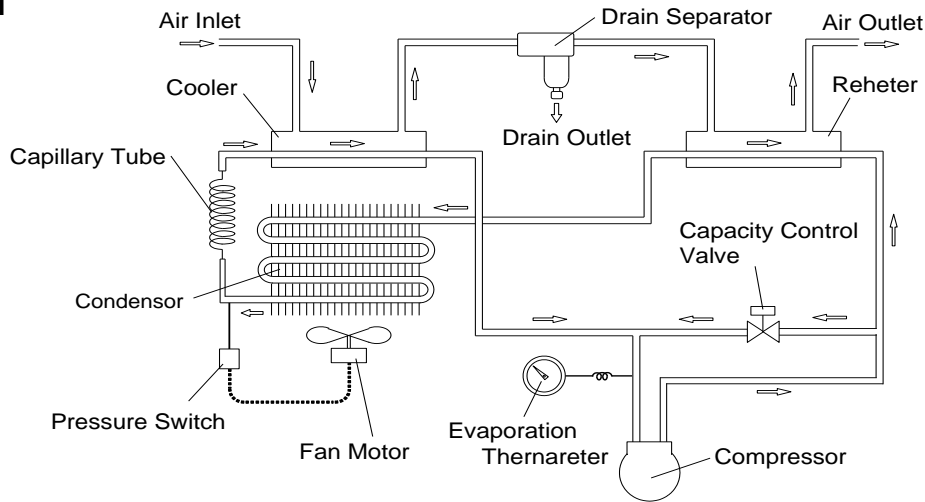

**IDFB4E to 15E-11**

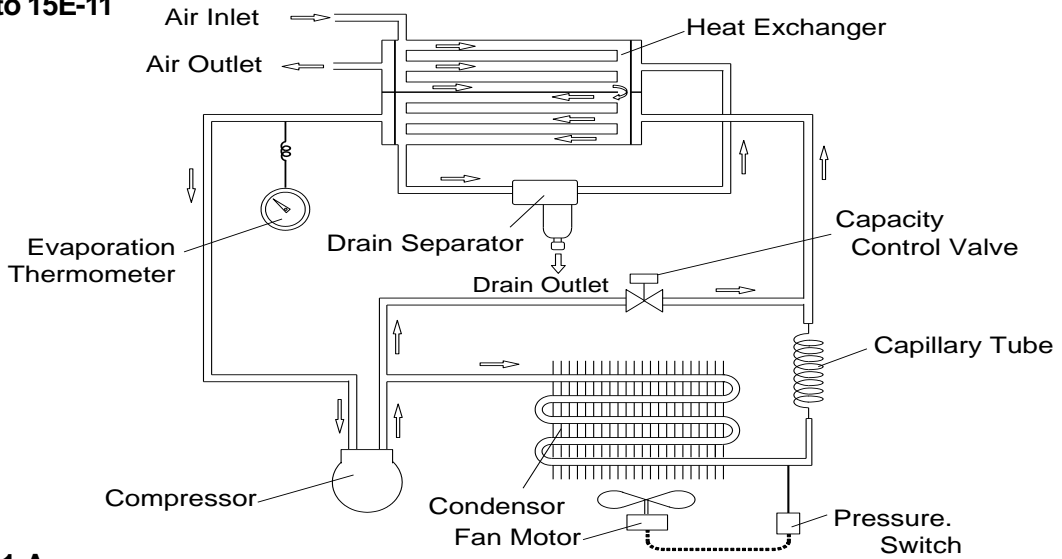

**IDFB3E-11-A**

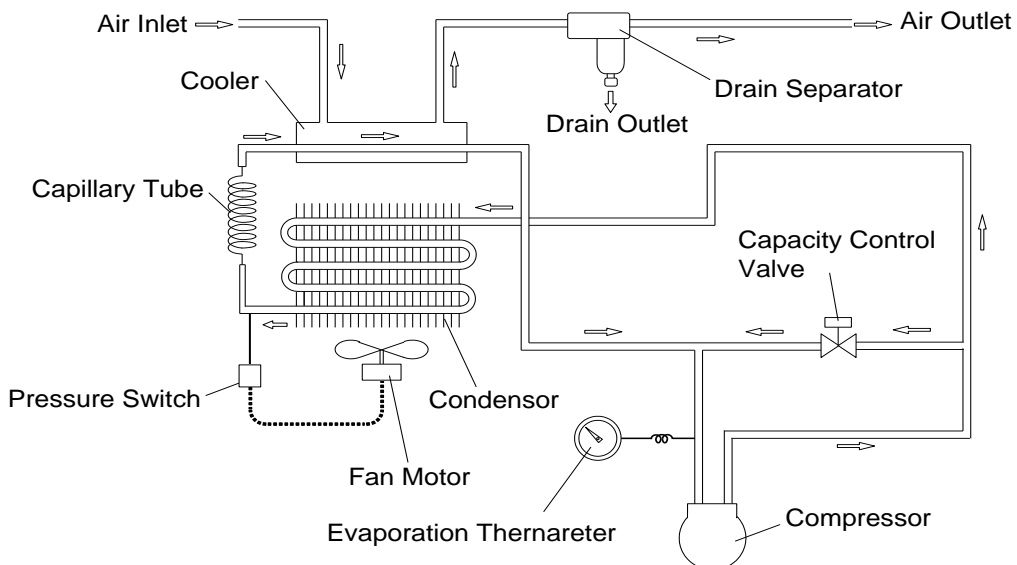

## IDFB4E to 11E-11-A

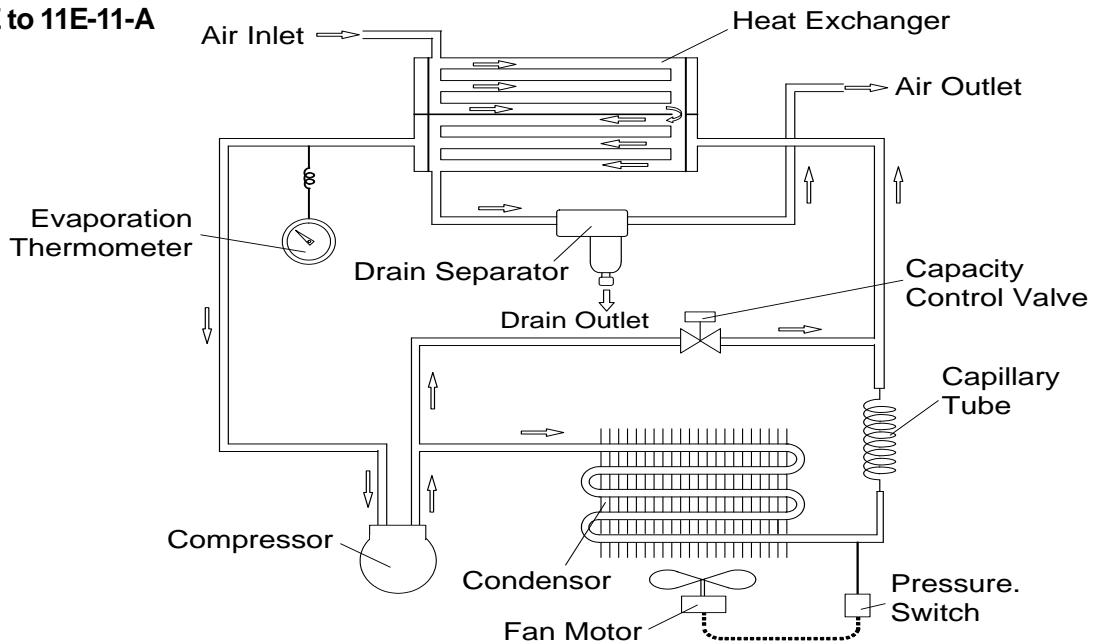
**Compressed Air Circuit**

Humid hot air entering air dryer is cooled in the cooler. At this time, the condensate is separated from the air by the drain separator and automatically discharged. The dry air is heated by the reheater until it gets about the same temperature as that of ambient air. It is then discharged from air dryer outlet.

**Refrigerant Circuit**

The Fluorocarbon charged in the refrigerant circuit is compressed by the compressor and cooled by the condenser to become liquid. Then, going through the capillary tube, the refrigerant pressure and temperature (evaporating temperature) decreased rapidly. Passing through the cooler part, it draws heat from the hot compressed air and intensely boils. Finally, it is sucked into the compressor again. The hot gas bypass valve opens to prevent compressor from freezing when compressed air is too cold.

**6-6 SERVICE PARTS LIST**

Parts No.	Description	IDFB3E	IDFB4E	IDFB6E	IDFB8E	IDFB11E	IDFB15E
IDF-S0001	Auto Drain Strainer	1	1	-	-	-	-
IDF-S0002	Auto Drain Strainer	-	-	1	1	1	1
AD38N-Z(Thread Symbol:N)	Auto Drain	1	1	-	-	-	-
AD48N-Z(Thread Symbol:N)	Auto Drain	-	-	1	1	1	1
AD38(Thread Symbol:None)	Auto Drain	1	1	-	-	-	-
AD48(Thread Symbol:None)	Auto Drain	-	-	1	1	1	1



## Specification for Option A

### 7-1 Safety instructions

When handling the product, take care to the following precautions.



### Warning

Shut off the power supply when removing the panel for maintenance work, etc. The product has a fan(s) and could cause serious danger to operators.

### 7-2 Specification

The specification for this air dryer is used for cooling down the compressed air. The compressed air comes out after cooled down and dehumidified without reheating. Remind that the air flow capacity is less than the standard models.

### 7-3 Air piping

Since cool air comes out from an outlet of air dryers, carefully attach thermal insulation to the piping at air outlet and keep the piping length as short as possible in order to prevent condensation on the outlet piping and temperature increase on the outlet due to ambient temperature.

### 7-4 Dryer specifications

Models	IDFB3E	IDFB4E	IDFB6E	IDFB8E	IDFB11E
Air flow rate (ANR)	5SCFM (8 m <sup>3</sup> /h)	13SCFM (23 m <sup>3</sup> /h)	17SCFM (29 m <sup>3</sup> /h)	19SCFM (32 m <sup>3</sup> /h)	23SCFM (39 m <sup>3</sup> /h)
Outlet air temp.	50° F (10°C)				

- The data for ANR is referring to the conditions of 68° F (20°C), 1atm. pressure & relative humidity of 65%.
- This air dryer for cooling compressed air indicates temperature, while the standard product indicates dew point of outlet air pressure.
- The conditions are the same as the ones for standard models other than air flow capacity.

**8****Specification for Option K**

This product mounts the auto drain in Item 2 Specifications. When performing the installation and maintenance of the product, the following points must be understood and followed. Additionally, for replacement work, read 4-2 "Periodical Maintenance" of the Operation Manual of standard product and keep safety.

**8-1 Safety instructions**

When handling the product, take care to the following precautions.

**Warning**

1. Do not remove the auto drain if air pressure remains of the product. When removing the auto drain, stop the supply of air to the primary side of the product, exhaust the air from the secondary side and ensure there is no residual pressure. If the air pressure is left at the inside of the product, parts could suddenly pop out and cause accident when loosened.
2. Put gloves to prevent injury when removing the auto drain.
3. Operator could touch the drain waste from repalced auto drain. Follow the procedures prepared by the customer to keep safety of operators. (Ex. Put protective goggles, apron and/or gloves to protect body from toucing the drain waste for replacement worken replacing the product.)

## 8-2 Specifications

The auto drain has a maximum operating pressure of 240psig (1.6MPa) and uses the metal case with a fluid level indicator.

### IDFB6E to 15E

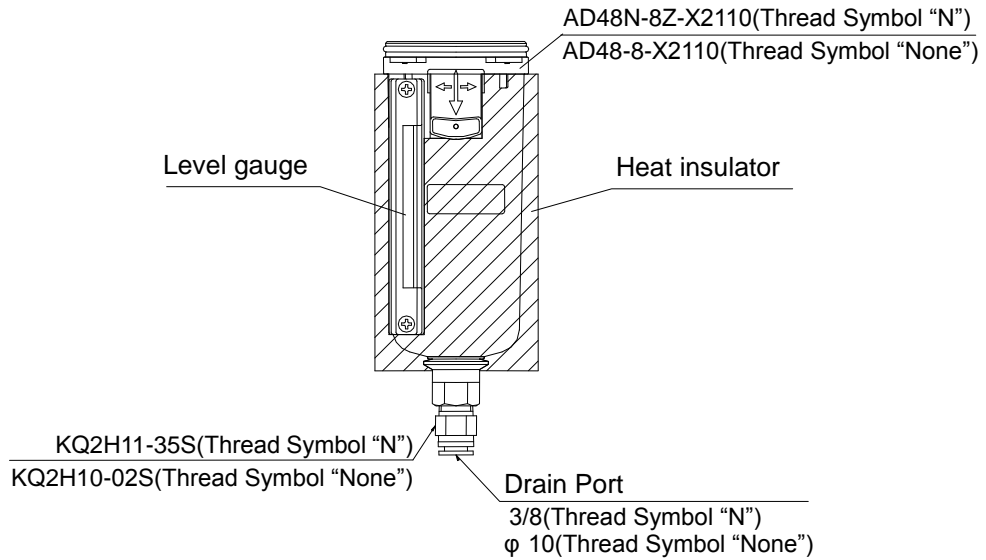

Item	Model	Thread Symbol "N"	Thread Symbol "None"
Auto drain		AD48N-8Z-X2110	AD48-8-X2110
Max. operating pressure		240psig (1.6MPa)	
Auto drain type		Float type	
Auto drain valve type		N.O. (normally opened: Released without pressurization)	
Working pressure		15 to 240psig (0.1 to 1.6MPa)	
Fluid		Compressed air	

## 9

**Specification for Option R**

This product mounts the Ground Fault Circuit Interrupter (GFCI) in Item 2. It will shut off the power supply in case the product should have over current or current leakage. Additionally, the power supply should be connected directly to the primary side of the GFCI. For the details of the GFCI such as the specifications and mounting position, refer to Item 2 or later.

**9-1 Safety instructions**

When handling the product, take care to the following precautions.

**Warning**

**Only qualified person must perform wiring and observing the following points.**

1. Be sure to shut off the power supply before wiring. For safety, do not perform any work on the unit with the power supply on. The power supply cannot be completely shut off just by turning off the illuminated switch. Be sure to turn off all power lines connected to the product.
2. Supply the power from a stable source, free from surges.
3. Provide the power suitable for the product specifications.
4. Be sure to ground the product for the safety. Without grounding, the GFCI can not operate normally.
5. Do not ground to water pipe, gas tube or lightning rod line.
6. Do not connect too many wires to the same outlet, which could results in heat generation and fire.
7. Do not retrofit the wiring of the dryer and the power supply line.

**9-2 Specifications of the GFCI**

Dryer model number	Specifications of GFCI
IDFB4E to 15E-11□-R	Rated current: 15A, Current sensitivity: 30mA

**9-3 How to connect the power supply**

Connect the power cables in the following procedure.

- 1) Take off the rear panel.
- 2) Insert the power cable prepared by the customer into the power code fixture and bring the power cable near the terminal base through the base hole.
- 3) Connect the power cable to the terminal of the GFCI.
- 4) Put back the rear panel.

**IDFB4E to 11E**

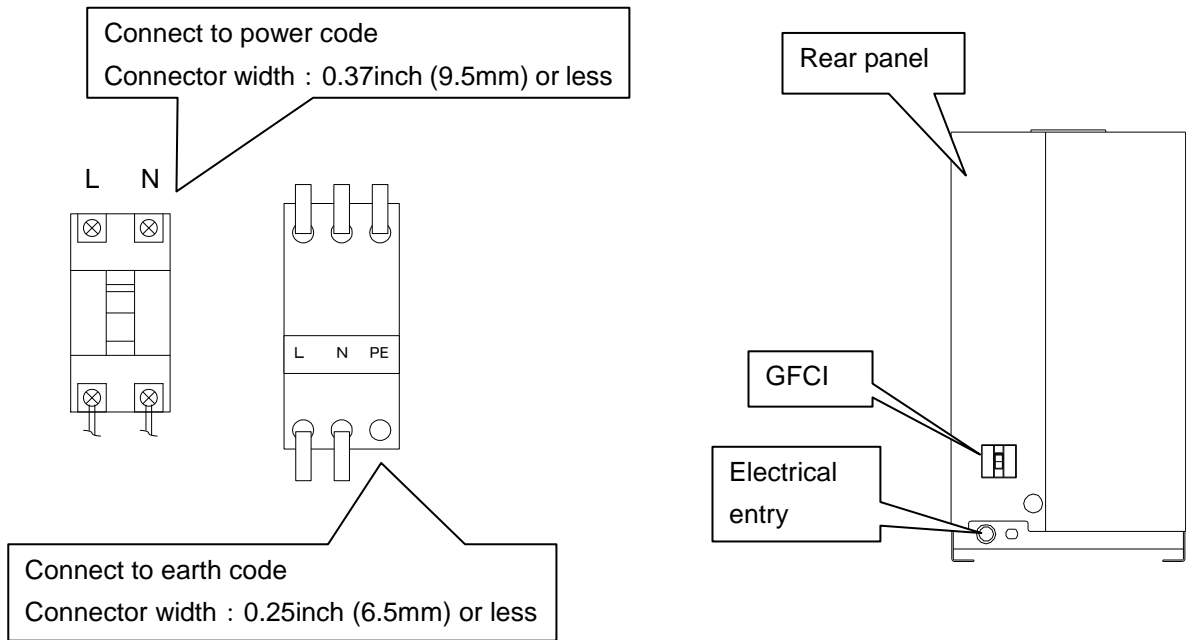

**IDFB15E**

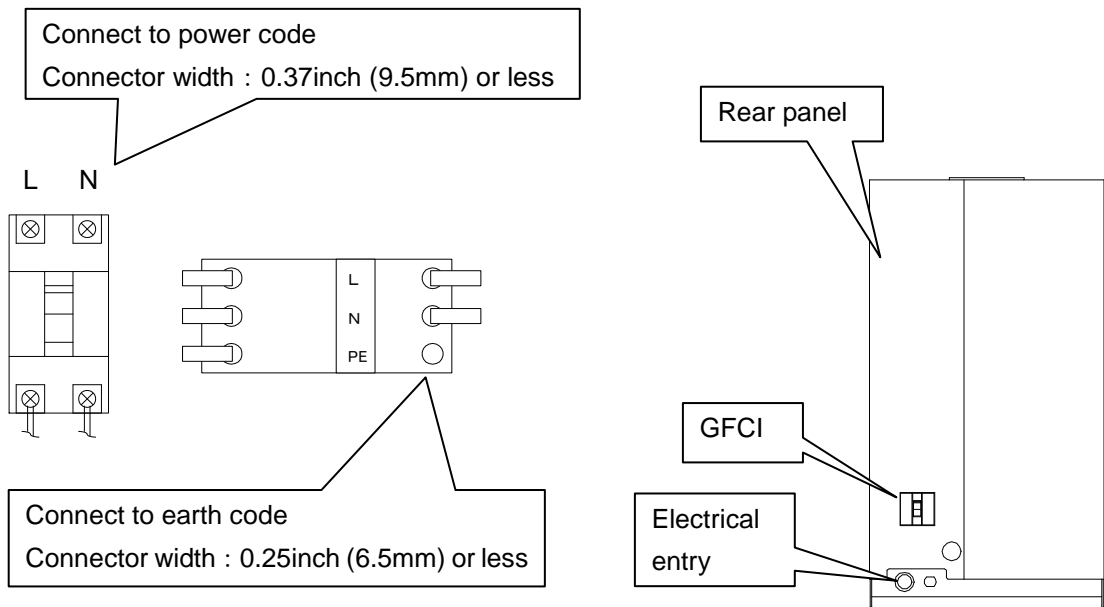



## Specification for Option S

### 10-1 Safety instructions

When handling the product, take care to the following precautions.



### Warning

**Only qualified persons are allowed to wire the product.**

1. Before wiring, be sure to shut off the power supply. Never perform wiring work while the product is energized.
2. Ensure a stable power supply with no voltage surges.
3. Use a power supply suitable for the specifications of the product.
4. Be sure to connect the ground connection.
5. Grounding should never be connected to a water line, gas line or lightning rod.
6. Multiple wiring is dangerous because it may lead to heat generation and cause a fire.
7. Do not modify the electrical wiring of the power supply.

### 10-2 Specifications

The option allows the connection of a power cable to a terminal block.

#### • IDFB3E

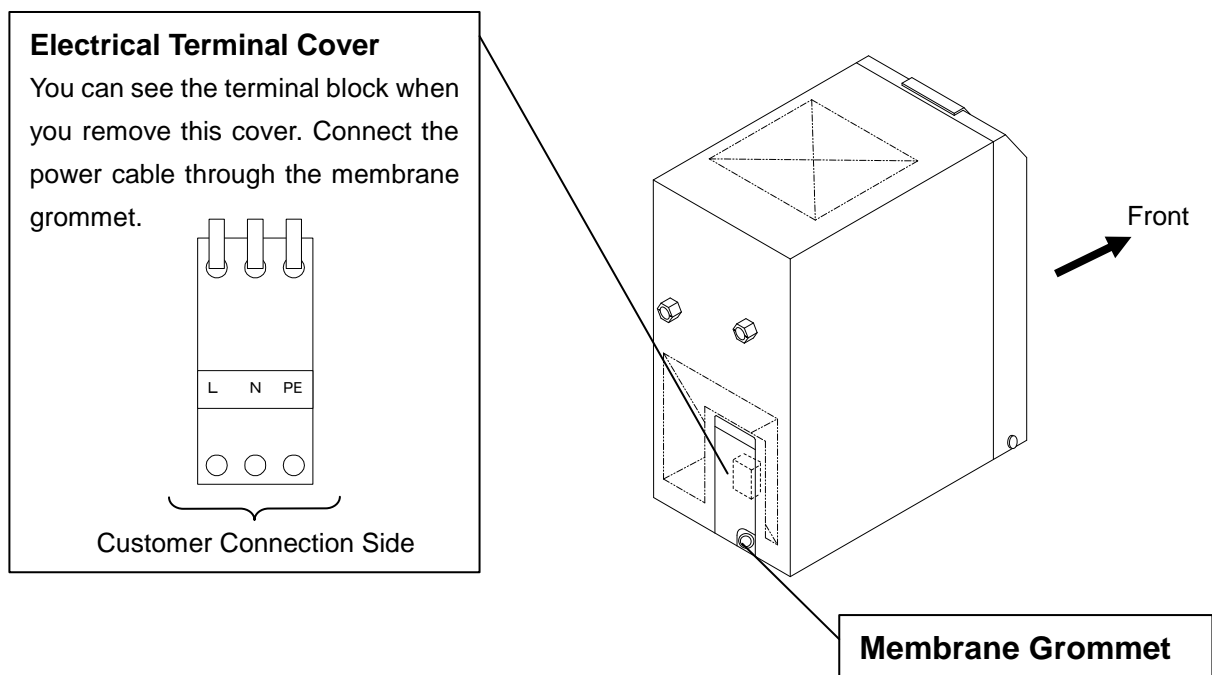



• IDFB4E to 11E

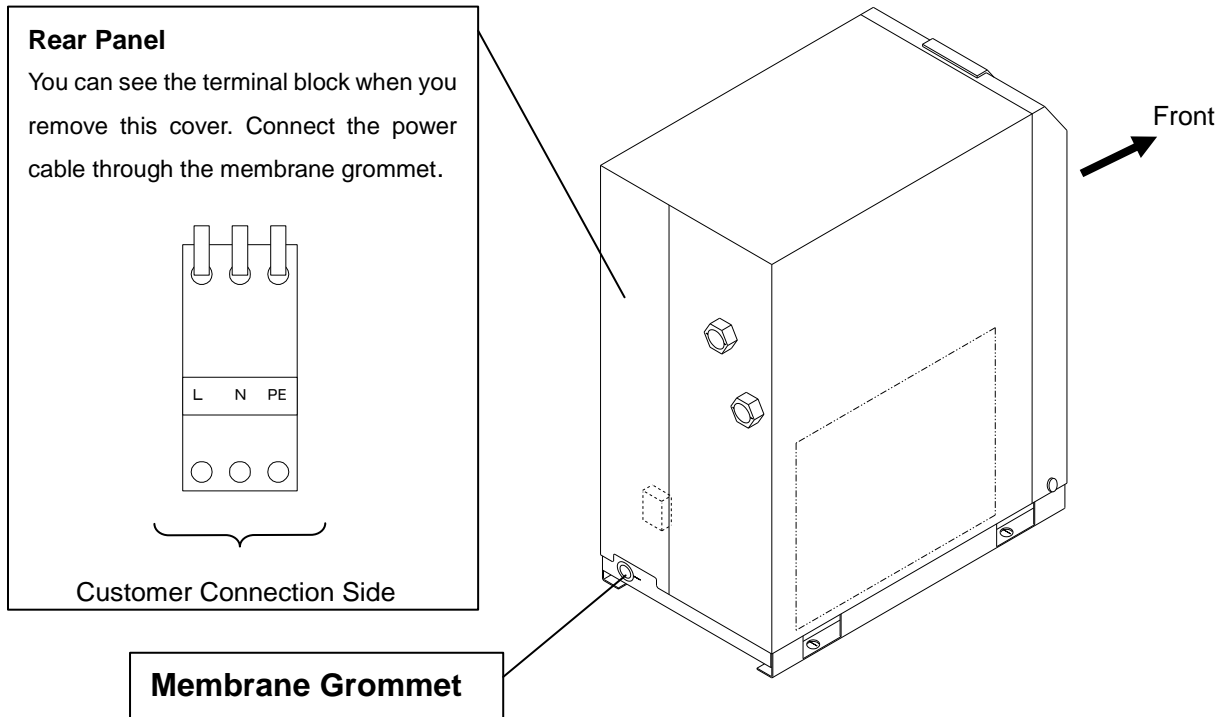

• IDFB15

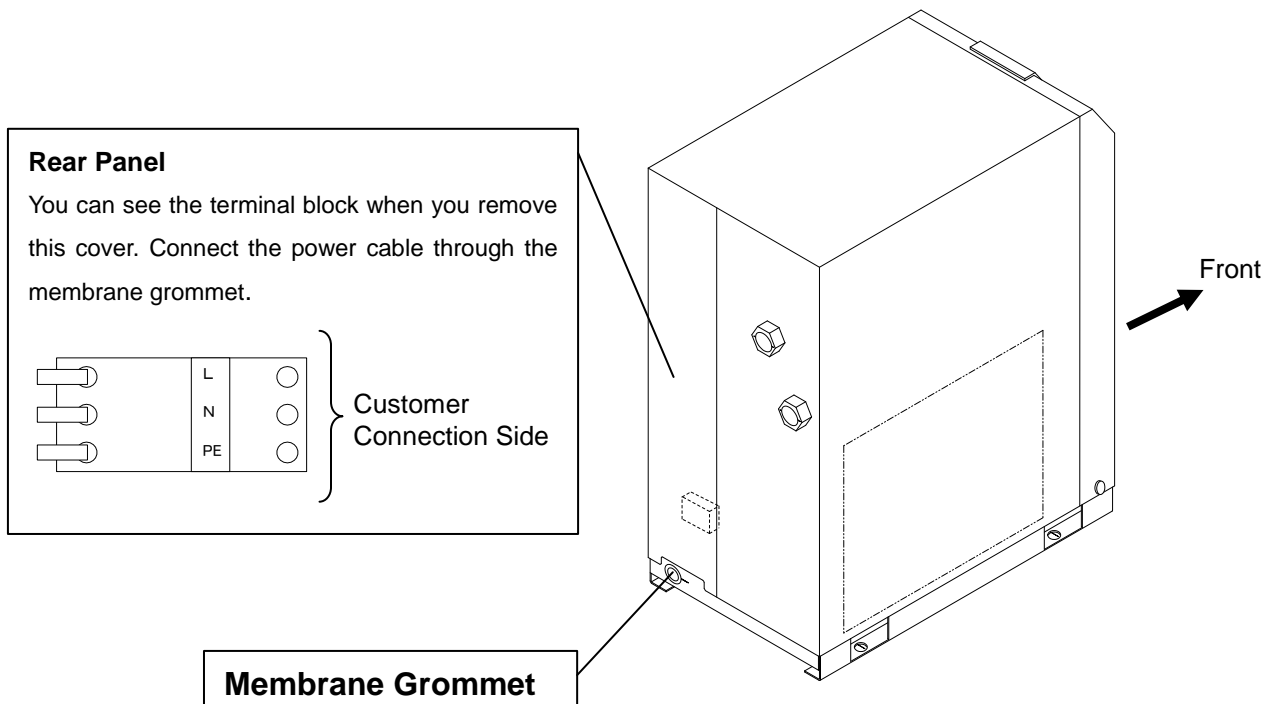



## Specification for Option T

This product mounts the terminal block which can transfer the operation and failure signals to Item 2 Specifications. The signals are a no voltage contact style. For details, refer to Item 2 or later.

### **11-1 Safety instructions**

When handling the product, take care to the following precautions.



### **Warning**

**Only qualified person must perform wiring and observing the following points.**

1. Be sure to shut off the power supply before wiring. For safety, do not perform any work on the unit with the power supply on. The power supply cannot be completely shut off just by turning off the illuminated switch. Be sure to turn off all power lines connected to the product.
2. Supply the power from a stable source, free from surges.
3. Be sure to mount the Ground Fault Circuit Interrupter (GFCI) with adequate sensitivity and load capacity to prevent electrical shock and protect the refrigerating compressor motor from burning out.
4. Provide the power suitable for the product specifications.
5. Be sure to ground the product for the safety. Without grounding, the GFCI can not operate normally.
6. Do not ground to water pipe, gas tube or lightening rod line.
7. Do not connect too many wires to the same outlet, which could results in heat generation and fire.
8. Do not retrofit the wiring of the dryer and the power supply line.
9. For the use of the product in Europe, mount the breaker compatible to IEC standard to the power supply for the product.

### **11-2 Specifications**

The product mounts the terminal block which can transfer the operation and failure signals on the standard product.

- The operation and failure signals are no voltage contact style.
  - Operation · · · · · When the product is operating; Close
  - Failure · · · · · When the product stops due to failure; Close
- Contact capacity
  - AC115V,5A DC24V,5A
  - Minimum current for signal 20V,5mA(AC/DC)

### 11-3 Remote operation

- For the remote operation, turn on and off the power supply side under the condition of the illuminated switch ON.
  - Keep 3 min. at minimum after stopping the product to restart even for the remote operation. If the product is restarted within less than 3 min., protective equipment (overload relay) may activate and prevent the product from restarting.
- Additionally, the frequency to start and stop the operation must be restricted to 5 times per hour (to prevent breakage of the motor).

### 11-4 How to connect the power supply and signal cable

Connect the power cable and signal cable in the following procedures.

- 1) Take off the rear panel.
- 2) Insert the power cable prepared by the customer into the power code inlet (with rubber grommet) and bring the power cable near the terminal block through the base hole.
- 3) Connect the power cable to the terminal.
- 4) Insert the signal cable prepared by the customer into the signal code inlet (with rubber grommet) and bring the signal cable near the terminal block.
- 5) Connect the signal cable to the each terminal.
- 6) Put back the rear panel.

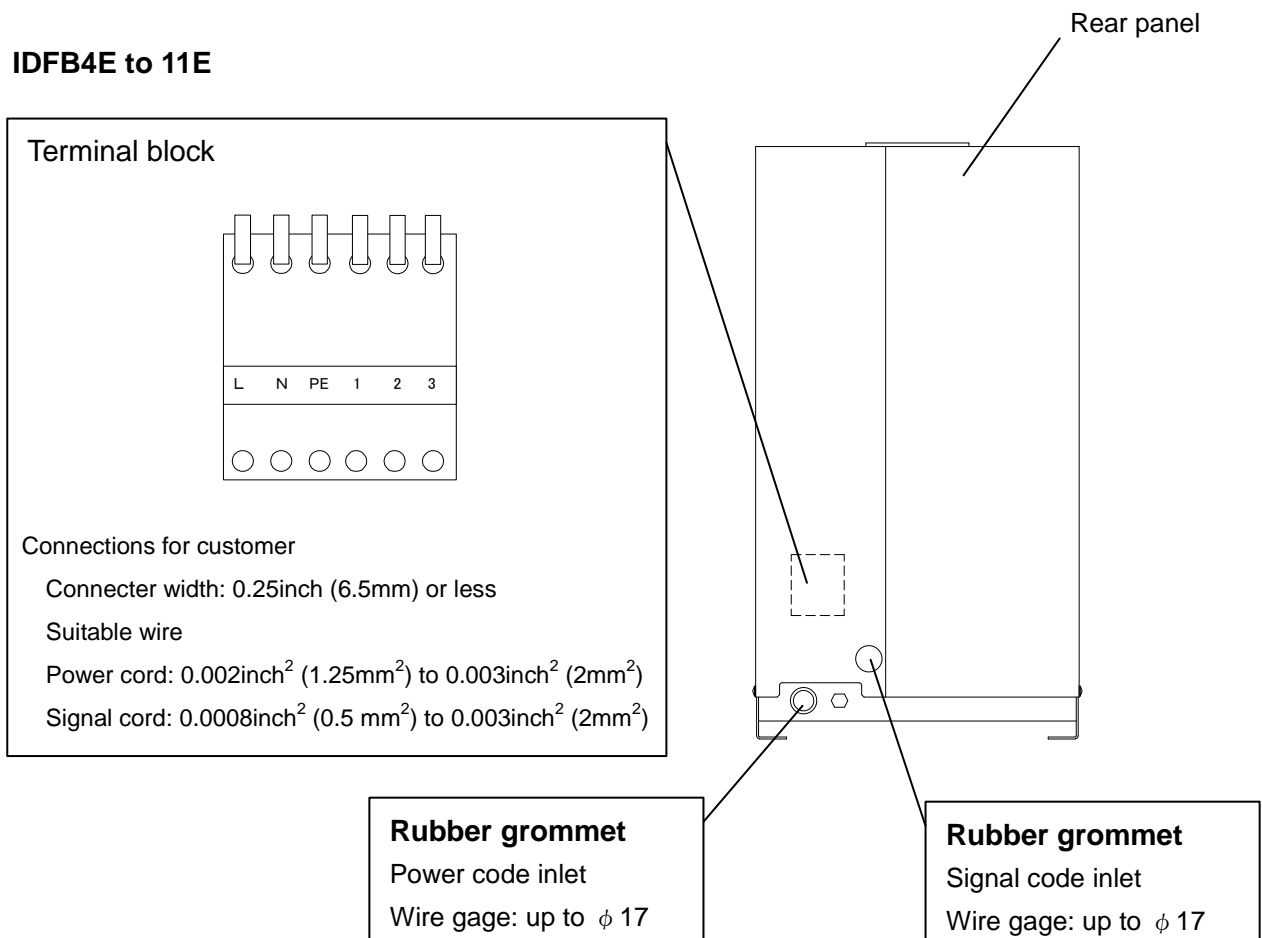

**IDFB15E**

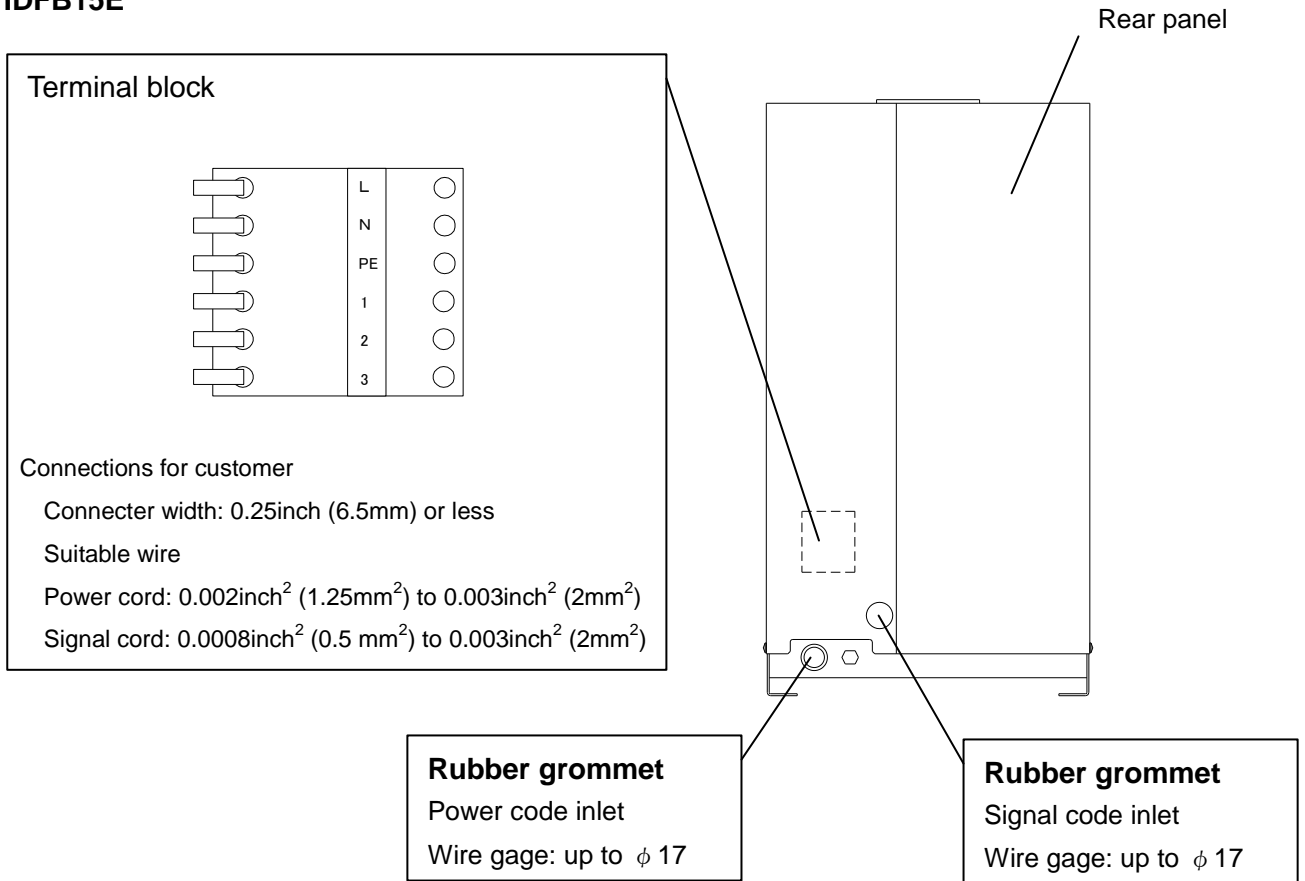

**11-5 Electric wiring diagram**

**IDFB4E to 11E-11□-T**

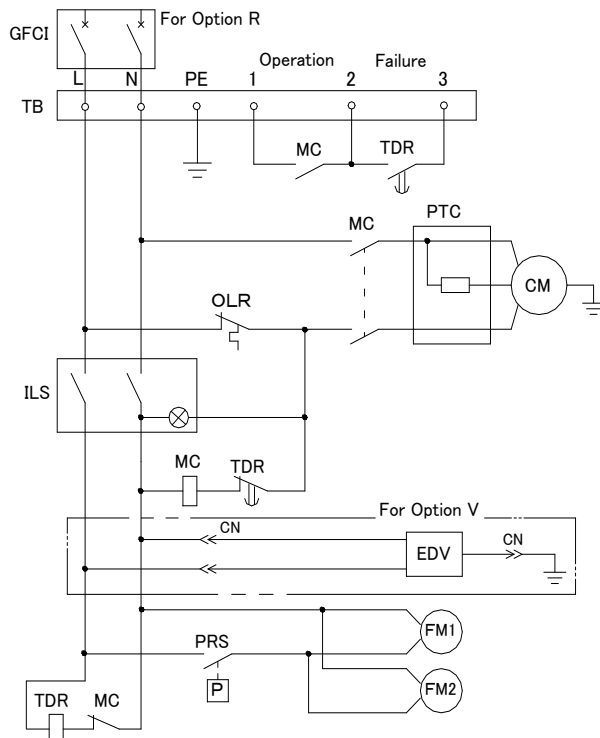

IDFB15E-11□-T

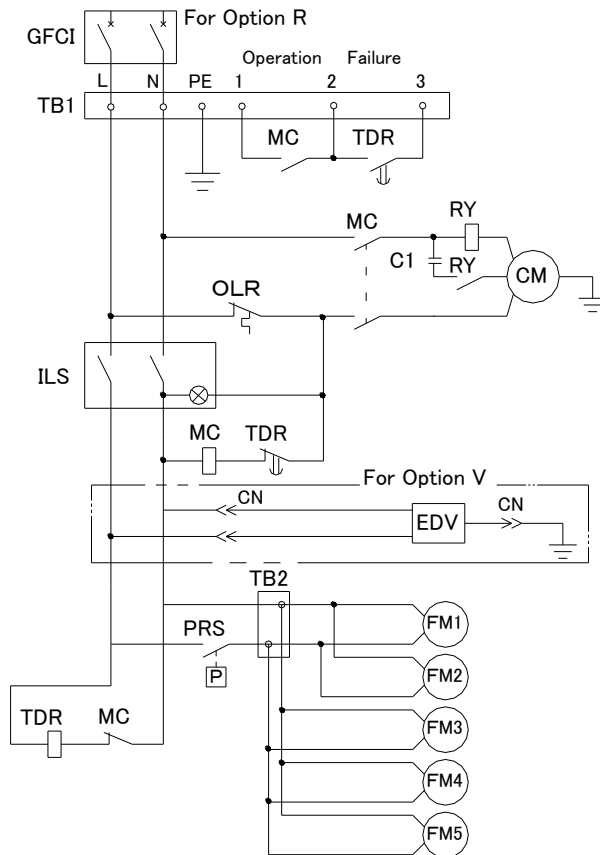

SYMBOL	DESCRIPTION
CM	Compressor Motor
FM1~5	Fan Motor
OLR	Overload Relay
C1	Capacitor For Compressor Motor
ILS	Switch with Lamp
PRS	Pressure Switch
PTC	PTC Starter
TB1~2	Terminal Block
MC	Magnetic Contactor
RY	Starting Relay
TDR	Time Delay Relay
GFCI	Ground Fault Circuit Interrupter
EDV	Electronic Drain Valve



## Specification for Option V

This product mounts the timer operated auto drain in Item 2 Specifications. When performing the installation and maintenance work for the product, the following points must be understood and followed. Additionally, read Item 3 for replacement work.

### 12-1 Safety instructions

When handling the product, take care to the following precautions.



#### Warning

1. Do not remove the auto drain if air pressure remains of the product. When removing the auto drain, stop the supply of air to the primary side of the product, exhaust the air from the secondary side and ensure there is no residual pressure. If the air pressure is left at the inside of the product, parts could suddenly pop out and cause accident when loosened.
2. Put gloves to prevent injury when removing the auto drain.
3. Operator could touch the drain waste from repalced auto drain. Follow the procedures prepared by the customer to keep safety of operators. (Ex. Put protective goggles, apron and/or gloves to protect body from toucing the drain waste for replacement worken replacing the product.)



#### Warning

**Only qualified person must perform wiring.**

1. Provide the power suitable for the product specifications.
2. Be suer to ground the product for the safety. Do not ground to water pipe, gas tube or lightening rod line.
3. Do not connect too many wires to the same outlet, which could results in heat generation and fire.
4. Do not retrofit the wiring of the dryer and the power supply line.

### 12-2 Specifications

The timer is set to have ON time of 0.5sec and OFF time of 0.5min. at the time of shipment from the factory. Do not change this timer setting. If it is changed, water could be discharged from the outlet line of the dryer. Service parts number will change depending on the power supply voltage of the dryer.

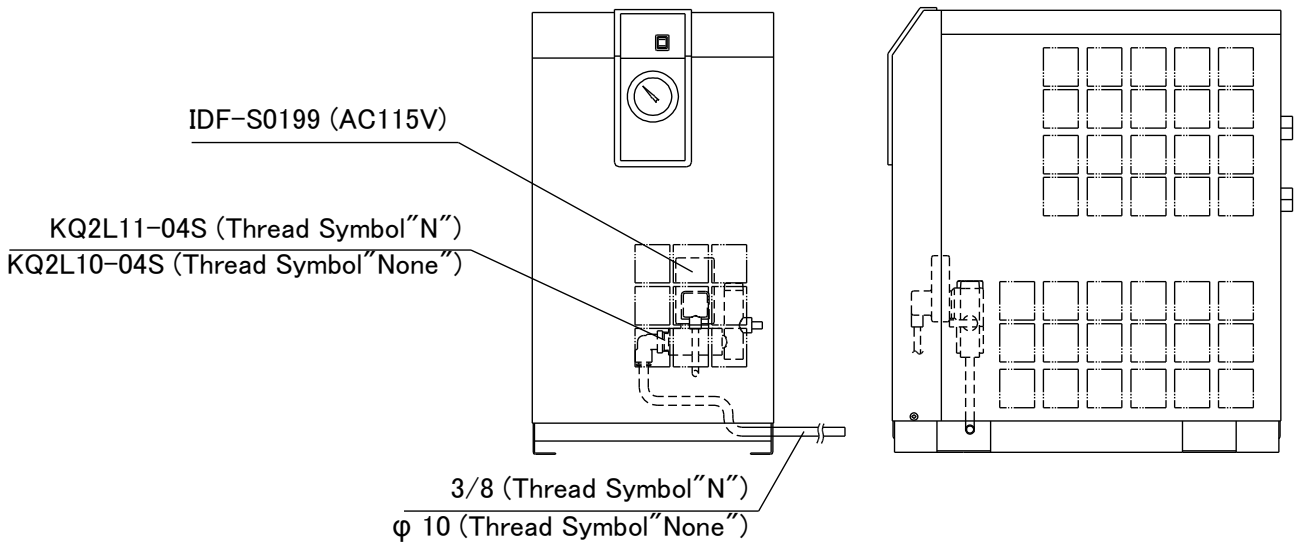

Power supply voltage of dryer	AC115V
Order number (service parts)	IDF-S0199
Max. operating pressure	240psig (1.6MPa)
Fluid	Drain
Power supply voltage of drain timer	AC115V±10% (60Hz)
ON time	0.5sec
OFF time	0.5min

### 12-3 How to perform maintenance

The product needs to be maintained. Clean it in the following procedure periodically.

- 1) Close the ball valve.
- 2) Press the test switch and make the residual pressure zero.
- 3) Remove the strainer and clean it.
- 4) Reassemble the strainer and open the ball valve.

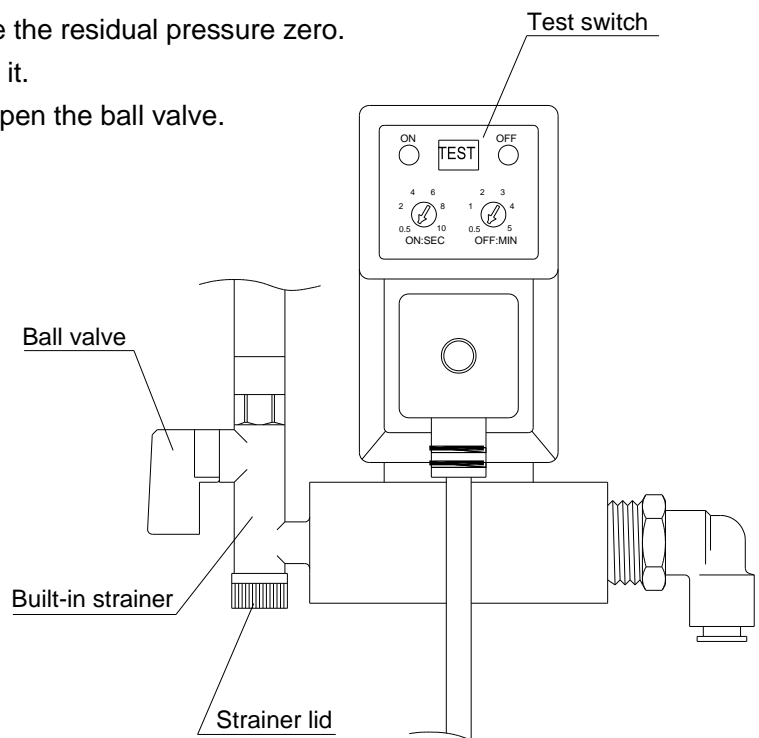

---

<b>13</b>	<b>Service Record</b>
-----------	-----------------------

**13-1 Service Record**

It is recommended to keep a maintenance/service record.

Parts No.	Description	Maintenance/Service Work Description	Date