

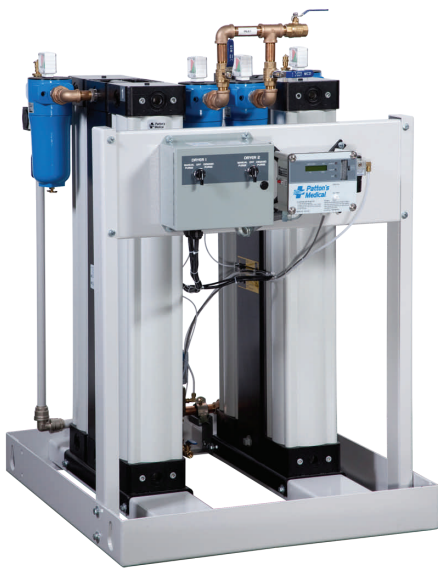

Retro-fit  
Medical Air Dryers



**Installation  
Operation and  
Maintenance  
Manual  
8-365 SCFM**



*Retro-Fit Desiccant Medical Air Dryer*

Model Number:	
Serial Number:	
Date Purchased:	
Purchased from:	

For further technical assistance, service or replacement parts, please contact:

**Patton's Medical**

3201 South Boulevard  
Charlotte, NC 28209

Customer Service: 1-866-960-0087

Phone: 704-529-5442

FAX: 704-525-5148

[www.pattonsmmedical.com](http://www.pattonsmmedical.com)

Please include the unit serial number located on the control panel with all inquiries.

Patton's Medical reserves the right to make changes and improvements to update products sold previously without notice or obligation.

Issue Date: April 26, 2016

## **Table of Contents**

### **Safety Precautions**

#### **1.0 General Information**

#### **2.0 Installation**

- 2.1 Inspection Upon Receiving
- 2.2 Handling
- 2.3 Location
- 2.4 Space Requirements
- 2.5 Piping
- 2.6 Wiring

#### **3.0 Operation**

#### **4.0 Start Up**

#### **5.0 Service and Fault Diagnosis**

- 5.1 Service shutdown
- 5.2 Service and maintenance
- 5.3 Service intervals
- 5.4 Removing and replacing the front panel
- 5.5 Purge plug removal for dryers 4-65 scfm
- 5.6 Purge plug removal for dryers 85-365 scfm
- 6.7 Cleaning the silencer for dryers 4-65 scfm
- 6.8 Cleaning the silencer for dryers 85-365 scfm
- 6.9 Replacing the diaphragm on dryers 4-65 scfm
- 6.10 Replacing exhaust valve assembly & shuttles on dryers 85-365 scfm
- 6.11 Resetting the controller

#### **6.0 Dryer Troubleshooting**

#### **7.0 Replacement Parts**

#### **8.0 CO Monitor**

#### **9.0 Ceramic Dew Point Monitor (Standard)**

#### **10.0 Warranty**

#### **11.0 Maintenance Record**

## Safety Precautions

Pressurized air from the system may cause personnel injury or property damage if the unit is improperly operated or maintained. The operator should have carefully read and become familiar with the contents of this manual before installing, wiring, starting, operating, adjusting and maintaining the system. The operator is expected to use common sense safety precautions, good workmanship practices and follow any related local safety precautions.

Patton's Medical explicitly excludes all responsibility and liability for damage and/or injury caused by failure to follow the instructions described in this manual, or by failing to pay necessary attention when operating handling or servicing this product, even if not specifically stated in individual cases.

The unit must be used for its intended purpose. The heatless-regenerating adsorption dryer is designed and manufactured exclusively for drying of compressed air within conditions as described in section 11 of this manual. Any other use of the unit will be considered inappropriate and Patton's Medical shall not be liable, where this is permitted under law, for any damage incurred as a result of misuse.

In addition:

- **Before starting any installation or maintenance procedures, disconnect all power to the package.**
- All electrical procedures must be in compliance with all national, state and local codes and requirements.
- A certified electrician should connect all wiring.
- Refer to the electrical wiring diagram provided with the unit before starting any installation or maintenance work.
- Release all pressure from the package before removing, loosening, or servicing any covers, guards, fittings, connections, or other devices.
- Notify appropriate hospital personnel if repairs or maintenance will affect available compressed air levels.
- Check all safety devices periodically for proper operation.
- Electrical service must be the same as specified on the control panel nameplate or damage to the equipment may occur.
- Vibration during shipment can loosen electrical terminals, fuse inserts, and mechanical connections. Tighten as necessary
- It is the responsibility of the installer to ensure that the pipe work to and from the dryer is suitable, in accordance with applicable legislation and subject to inspection and testing prior to being put into service. All piping must be adequately supported.

**Safety Precautions (continued)**

- Before carrying out any maintenance or servicing work the unit must be taken out of operation. Users and others will be exposed to risk if work is carried out whilst the unit is running. This means electrical disconnection plus isolation from the compressed air supply and full depressurization.
- Only trained and competent persons familiar with the electrical requirements of the unit as laid out in this manual and electrical safety rules and regulations should be allowed to carry out work on the electrical components and power supply to the unit.
- When carrying out any work on the unit, use only correctly sized appropriate tools in good condition.
- Only use original spare parts and accessories from the manufacturer. There is no guarantee that non-original parts have been designed and manufactured to meeting the safety and operational requirements of the unit. The Company assume no liability for any equipment malfunction resulting from the use of non-approved parts.
- Do not make any constructional changes to the product. Any changes or modifications may only be carried out by the manufacturer.
- Any faults or defects that could affect safety must be put right fully before using the unit.
- Used items and materials must be disposed of in the correct manner, complying with local laws and regulations, in particular the desiccant cartridge.

## **1.0 General Information**

### **Duplex Dryer System**

The retro-fit dryer package consists of two desiccant twin tower air dryers with an integral demand based purge saving control system, two pre-filters, two after filters, two final line regulators and safety relief valves. The unit is equipped with a four valve bypass for dryer maintenance. The isolation valves permit servicing without shutting down the medical air system. Each unit also has an air sample port as required by NFPA.

### **Dryer**

The dryer is a twin tower, pressure swing adsorption, regenerative type. Each dryer is individually sized for peak calculated demand and capable of producing a 10° F (-12° C) pressure dew point. The desiccant is contained within a packed bed canister to prevent excessive downstream dusting. Located in the top of each canister is a 1-micron filter for removal of residual dust from the desiccant. The length of the canister varies with the flow capacity of the dryer. The canisters are contained within an extruded aluminum pressure housing and pressure retaining end plates. Air pressure and flow through each desiccant cartridge is controlled by means of top and bottom valve manifolds located between the two pressure housings. The regenerating air flow (purge) is controlled by means of a small orifice plug. Purge flow is minimized through an integral purge saving control system.

### **Pre-filter**

Each dryer has a high efficiency coalescing pre-filter rated for 0.01 micron mounted on it with an automatic solenoid drain valve and an element change indicator.

### **After Filter**

Each dryer also has a particulate final line filters rated for 0.01 micron mounted on it with an element change indicator.

### **Regulator/ Safety Relief Valve**

The dryer package is equipped with dual regulators factory set @ 55 PSI and a safety relief valves rated for 75 PSI.

### **Dew Point Hygrometer/**

A dew point hygrometer/CO monitor with integral chemical CO sensor - mounted, is pre-piped, wired and includes remote alarm contacts. The hygrometer sensor is a ceramic type with an accuracy of a minimum of  $\pm 2^{\circ}$  F for dew point and  $\pm 2$  PPM (at 10 PPM) for carbon monoxide. The dew point alarm is factory set at 36° F (2° C) per NFPA 99 and the CO alarm is factory set at 10 PPM. The set points are not field adjustable. High CO and high dew point conditions are indicated with visual and audible alarms.

## 1.0 General Information

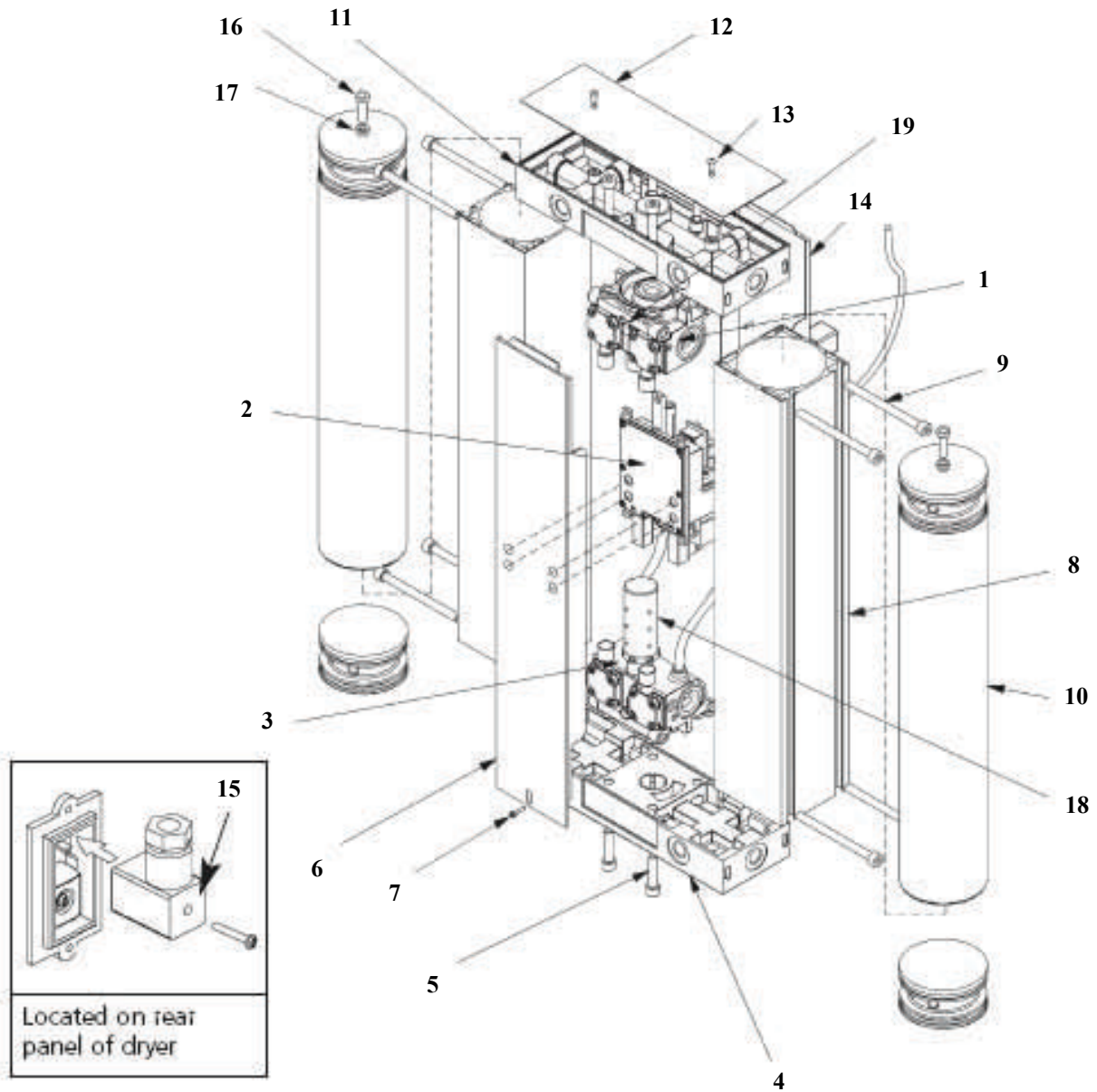

### Main elements of an 8-65 scfm dryer

- 1 Top valve assembly
- 2 Control unit
- 3 Bottom valve assembly
- 4 Bottom mounting block
- 5 Bottom valve fixing bolt

- 6 Front panel
- 7 Front panel screw
- 8 Pressure housing
- 9 Pressure housing retaining bolt
- 10 Desiccant cartridge w/dust filter

**1.0 General Information**

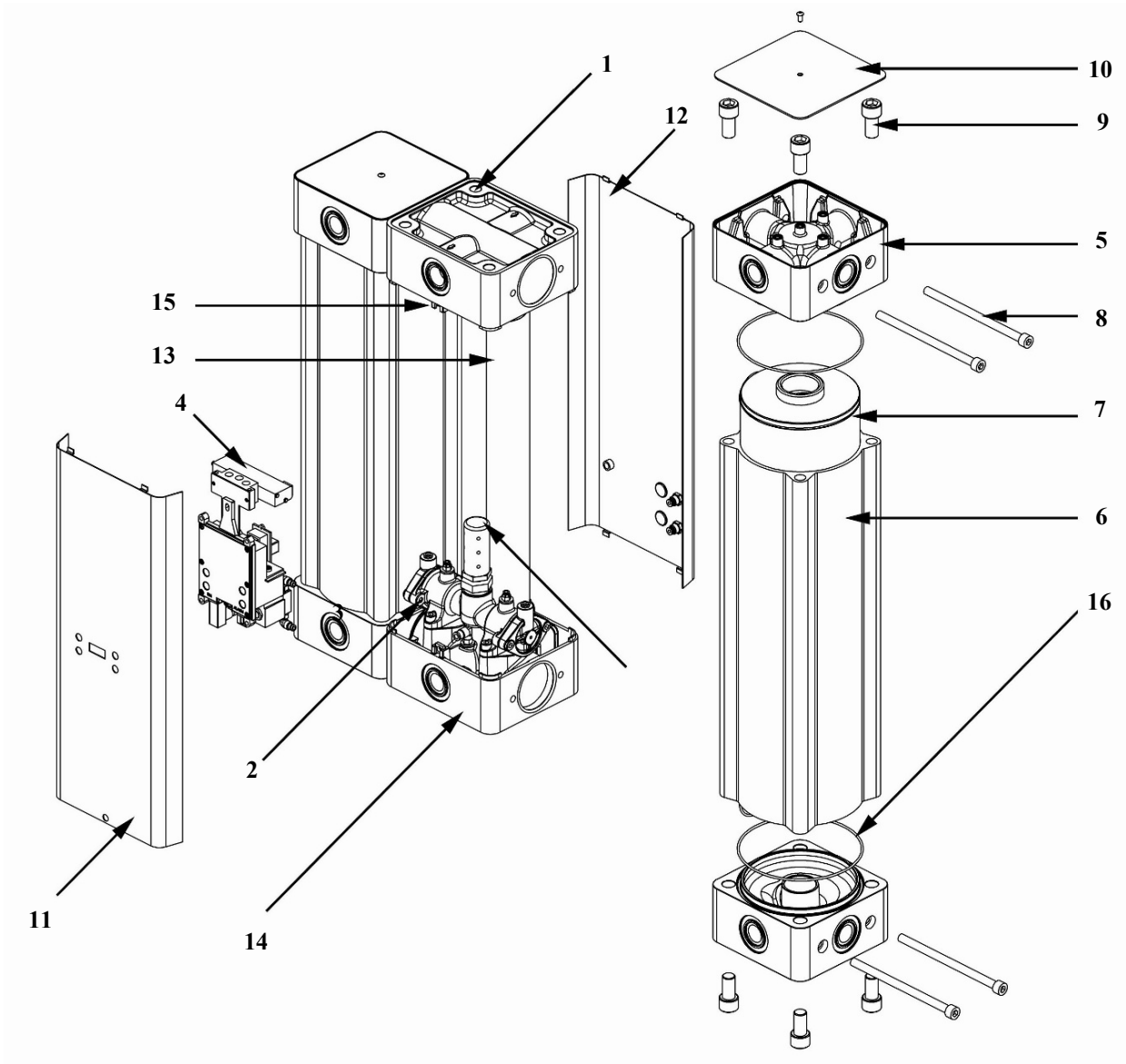

**Main elements of an 85-365 scfm dryer**

- |                          |                                       |
|--------------------------|---------------------------------------|
| 1 Inlet valve assembly   | 6 Pressure housing                    |
| 2 Bottom valve assembly  | 7 Desiccant cartridge w/dust filter   |
| 3 Exhaust valve assembly | 8 Pressure housing retaining bolt     |
| 4 Control/valve unit     | 9 Quadra-port manifold retaining bolt |
| 5 Quadra-port manifold   | 10 Quadra-port manifold top cover     |



## 2.0 Installation

### 2.1 Receiving Inspection

The medical air desiccant dryer package should be carefully inspected upon delivery. Any damage by the carrier should be noted on the delivery receipt, especially if the system will not be immediately uncrated and installed. The unit may remain in its shipping container until ready for installation. If the unit is to be stored prior to installation, it must be protected from the elements to prevent rust and deterioration.

**DO NOT REMOVE** the protective covers from the inlet and outlet connection ports of the unit until they are ready for connecting to the hospital's pipeline distribution system.

### 2.2 Handling

**!!WARNING!!**

**USE APPROPRIATE LOAD RATED LIFTING EQUIPMENT AND OBSERVE SAFE LIFTING PROCEDURES DURING ALL MOVES.**

The dryer package can be moved with either a forklift or dollies. Keep all packing in place during installation to minimize damage. Examine the route the unit must travel and note dimensions of doorways and low ceilings. Units should be placed to ensure easy access to perform maintenance and high visibility of indicators and gauges.

### 2.3 Location

The medical air dryer should be installed indoors in a clean, well-ventilated environment. Areas of excessive dust, dirt or other air-borne particulate should be avoided.

Secure the package to a flat, level surface capable of supporting the weight of the unit. Make sure that the main base is not bowed, twisted, or uneven. **No special foundation is required.** However, the unit base can be securely bolted using all mounting holes provided in the base. If a raised concrete pad is used, the base must not overhang the concrete pad. A method to drain away moisture is necessary. If a gravity drain is not available, a connection to a drain is necessary.

The area should have an average ambient temperature of 70°F (21°C) with a minimum ambient temperature of 40°F (4.4°C) and a maximum ambient temperature of 100°F (37.8°C). (**Note: At temperatures below 32°F freezing of the condensate can occur which could affect operation.**)

## **2.0 Installation (continued)**

### **2.4 Space Requirements**

The medical air dryer should be placed to ensure easy access to perform maintenance and high visibility of indicators and gauges. It is recommended that a minimum space of 24" be allowed on all sides of the unit for ventilation and maintenance. A minimum space of 36" in front of the control panel is required by NEC code. A vertical distance of 36" is required above the unit for ventilation and maintenance.

### **2.5 Piping**

Size intake and discharge piping to ensure that airflow restriction will not occur. All piping must be pre-cleaned for medical gas in accordance with NFPA 99.

### **2.6 Wiring**

**Refer to the electrical diagram provided with the unit before starting any installation or maintenance work.**

**Do not operate the dryer on a voltage other than the voltage specified on the dryer nameplate.**

**All customer wiring should be in compliance with the National Electrical Code and any other applicable state or local codes.**

**Refer to the wiring diagram that came with the dryer for specific wiring connections.**

**Electrical power for the medical air dryer must be supplied from the emergency life support circuit.**

Check the control voltage, phase, and amp ratings before starting the electrical installation, and make sure the voltage supplied by the hospital is the same.

The wire size should be able to handle peak amp load.

Check all electrical connections within the dryer that may have loosened during shipment.

Only qualified electricians should make power connections to the control panel and any inter-connecting wiring.

Ensure that the emergency generator system's electrical supply is consistent with the dryer's requirements.

### **3.0 Operation**

The dryer operation is designed to give smooth, uninterrupted delivery of compressed air to the designated specification. During the cycle of operation, the first pressure housing is fully pressurized and airflow is directed upwards through the desiccant cartridge, removing moisture from the air during its passage, to the minimum specified dew point.

During the drying cycle, a small bleed of dry air (purge) is directed to the opposite pressure housing. This purge air flows down through the desiccant cartridge and to atmosphere by means of an exhaust silencer, thereby effecting regeneration of the desiccant.

#### **Manual Purge**

In Manual Purge the dryer will shift after 120 seconds of operation, the cartridge under regeneration is sealed by closing of the exhaust valve and the pressure housing is brought up to full system pressure by the purge air.

After 170 seconds, the pressure in the first housing is released to atmosphere by means of the corresponding exhaust valve and the desiccant cartridge then operates in regeneration mode. The main air flow and drying function is then transferred to the desiccant cartridge that was previously under regeneration.

The cycle of operation continues in this pattern with the cartridges switching alternately between drying and regenerating.

#### **Demand Purge**

In Demand Purge the dryer will operate the same as manual purge if the dew point is above  $-10^{\circ}\text{C}$ . If the dew point is below  $-10^{\circ}\text{C}$ , both exhaust valves will close and purge air will stop.

#### 4.0 Start up

1. Close all valves.
2. Switch on compressor.
3. Open dryer inlet valve slowly.
4. Check there are no leaks from the dryer.
5. Switch on electric power. All four display panel LED's will flash simultaneously green four times then simultaneously red four times to acknowledge application of power and readiness to function. Observe display panel for one complete cycle. Note: cycle described is factory setting.

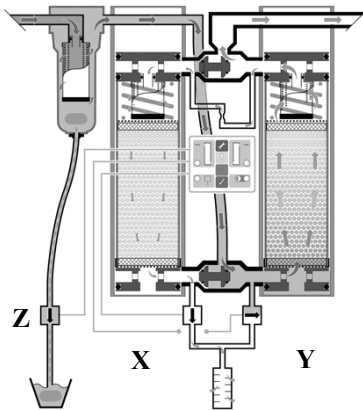

Fig. 5.1 Dryer in operation

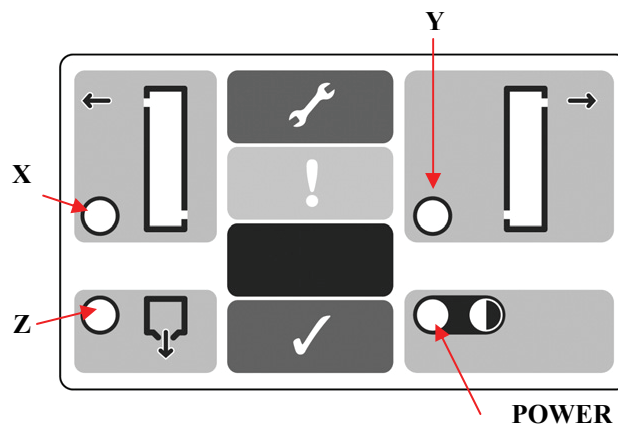
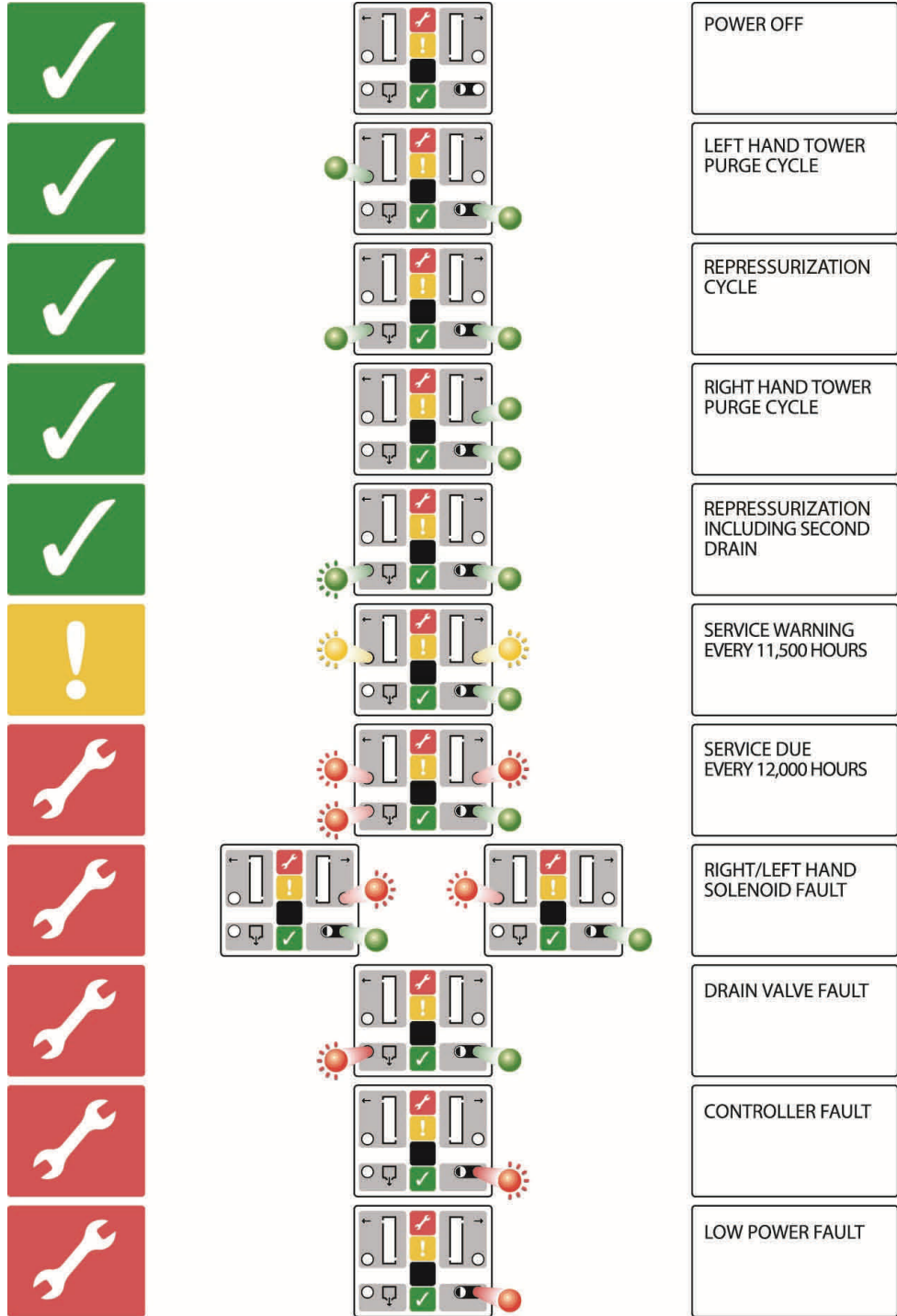

Fig. 5.2 Display panel

1. Power LED illuminates green and tower LED X illuminates green.
2. After 120 seconds, tower LED X switches off and drain LED Z illuminates green.
3. After a further 50 seconds drain LED Z switches off and tower LED Y illuminates green.
4. After a further 120 seconds, tower LED Y switches off
5. After a further 50 seconds, tower LED X illuminates green - this is (1) in the cycle described above.
6. The above cycle (1-4) repeats.
7. Run the dryer for a minimum of 6 hours to ensure dew point is adequate.
8. Open valve B slowly.

## 5.0 Service and fault diagnosis



OK

WARNING

ACTION

## 5.0 Service and fault diagnosis (continued)

### 5.1 Service shutdown

1. Close dryer outlet valve
2. Close dryer inlet valve
3. Leave dryer running for 15 minutes to fully de-pressurize
4. Switch off all electrical power to the dryer

Under no circumstances must compressed air be allowed to flow through the dryer following switch off of electrical power. This will result in terminal failure of the desiccant cartridges and regeneration will not be possible.

### 5.2 Servicing and maintenance

1. Service intervals are every 12,000 operational hours. See chart below.
2. The shutdown procedure (above) must be carried out before a service is carried out.
3. The following kits are available. (See Section 7.0 for replacement kits.)

<b>Kit A: 12,000 hour service kit</b>
Desiccant cartridges (where applicable)
Pre-filter element (where applicable)
O-rings and seals
Re-set disc
Instruction leaflet

<b>Kit B: 24,000 hour service kit</b>
Desiccant cartridges (where applicable)
Pre-filter element (where applicable)
O-rings and seals
Re-set disc
Exhaust valve solenoids (controller)
Exhaust Shuttles
O-rings and seals
Instruction leaflet

## 5.0 Service and fault diagnosis (continued)

### 5.3 Service Intervals

Service Intervals	Kits Required
2 years or 12,000 hours	Kit A
4 years or 24,000 hours	Kit B
6 years or 36,000 hours	Kit A
8 years or 48,000 hours	Kit B
10 years or 60,000 hours	Recommended service overhaul. Please contact the Patton's Medical

### 5.4 Removing and replacing the front panel

1. Dryer with front fascia panel fitted.
2. Remove single retaining screw.
3. Remove front fascia panel by tilting outwards and downwards.
4. Dryer with front fascia panel removed.
5. Re-fit front fascia panel by insertion of tongue into groove and pushing upwards and inwards.
6. Replace single retaining screw.



1

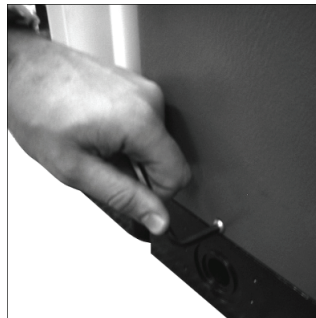

2

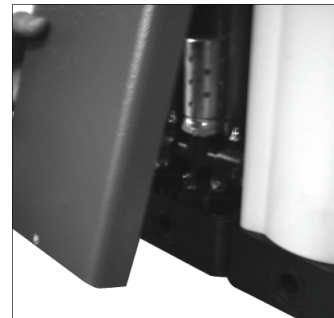

3



4

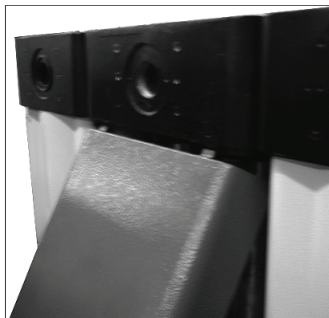

5



6

## 5.0 Service and fault diagnosis (continued)

### 5.5 Purge plug removal for dryers 4-65 scfm

1. Remove front panel of dryer as described in 5.4 and locate purge plug in upper valve block.
2. Remove purge plug screw from upper valve block.
3. Remove purge plug from port in upper valve block downwards.
4. Orifice in purge plug can be cleaned with warm soapy water. Do not use sharp implements or tools.
5. After thoroughly drying the purge plug, push back into port in valve block. Ensure that the o-rings are in place and in good condition.
6. Replace and tighten purge plug screw in upper valve block.



1



2



3

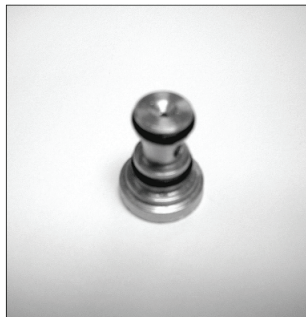

4



5



6



### 5.0 Service and fault diagnosis (continued)

#### 5.6 Purge plug removal for dryers 85-365 scfm

1. Remove front panel of dryer as described in 5.4 and locate purge plug in between the two bonnets.
2. Remove bonnet fixing screws from upper valve block. Remove bonnet from valve manifold block.
3. Remove purge plug from port in bonnet downwards. This will allow the purge plug to be removed.
4. Orifice in purge plug can be cleaned with warm soapy water. Do not use sharp implements or tools.
5. After thoroughly drying the purge plug, ensure that 'O' rings are in place and in good condition. Locate between the bonnets.
6. Replace and tighten bonnets.



1



2

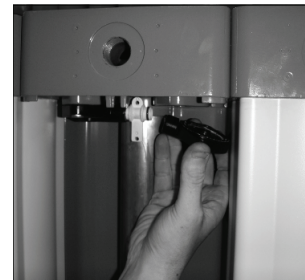

3



4



5



6

## 5.0 Service and fault diagnosis (continued)

### 5.7 Cleaning the silencer for dryers 4-65 scfm

1. Silencer removal is best carried out during diaphragm replacement. See 5.9.
2. Disconnect silencer from valve block.
3. Remove silencer from dryer.
4. Clean threads on silencer.
5. Silencer can be thoroughly cleaned in warm soapy water. Do not use sharp instruments or tools.
6. Ensure silencer is thoroughly clean and dry then replace by following the above procedure in reverse.

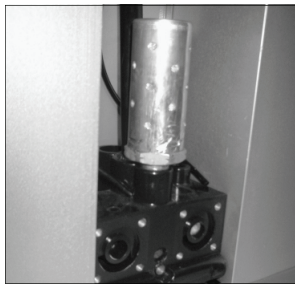

1



2



3

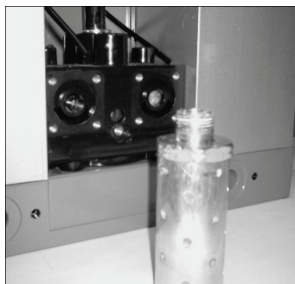

4

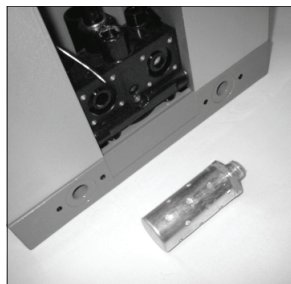

5

## 5.0 Service and fault diagnosis (continued)

### 5.8 Cleaning the silencer for dryers 85-365 scfm

1. Disconnect silencer from valve block.
2. Silencer can be thoroughly cleaned in warm soapy water. Do not use sharp instruments or tools. Clean threads on silencer.
3. Ensure silencer is thoroughly clean and dry then replace by following the above procedure in reverse.



1

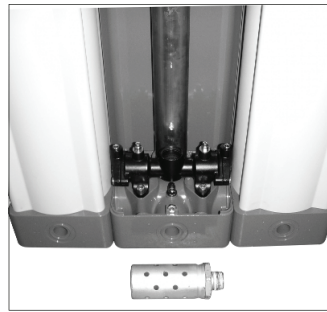

2

## 5.0 Service and fault diagnosis (continued)

### 5.9 Replacing the diaphragm on dryers 4-65 scfm

1. Remove front panel as described in 5.4 and locate position of upper and lower bonnets.
2. Lower bonnets.
3. Remove bonnets by means of four screws.
4. Separate bonnet from valve block.
5. Disconnect tubing from fitting on bonnet.
6. Locate diaphragm assembly to be changed.
7. Remove diaphragm assembly.
8. Diaphragm and bonnet components.
9. Replace diaphragm and bonnet by following above procedure in reverse. Repeat above procedure for all diaphragms on dryer.



1



2



3



4



5



6



7

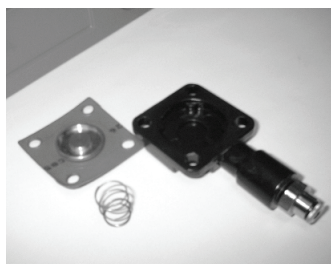

8

### 6.0 Dryer Troubleshooting

#### 6.1 General troubleshooting

Before specific identification of any fault is looked for, the following general points must be verified:

- Has the unit been damaged externally or are any parts missing?
- Is power being supplied to the unit?
- Was startup carried out in accordance with the instructions in this manual?
- Are all external valves correctly set for operation?
- Do the operational conditions meet those specified at time of ordering and used for product selection?

The table below gives possible causes and corrective actions to faults that may occur on the dryer:

General Troubleshooting Guide		
Problem	Possible Cause	Action
Poor Dew Point	Liquid water at dryer inlet	Check pre-filter and drains
	Excessive flow	Check against specification
	Low inlet pressure	Check against specification
	High inlet temperature	Check against specification
	Silencer blocked or damaged	Replace silencer
	Air leaks	Tighten joints or fit new seals
Incorrect dryer operation	Jammed shuttle valves or faulted electrical components	See electrical operation troubleshooting

## 5.0 Service and fault diagnosis (continued)

### 5.10 Replacing the exhaust valve assembly and exhaust shuttles on dryers 85-365 scfm

1. Remove front panel of dryer as described in 5.4.
2. Remove the cap screws securing the manifold in position.
3. Remove the manifold, taking care to retrieve the inter face O-rings. The silencer can be removed for maintenance if required.
4. Remove end bonnets, retrieving the O-ring.
5. Remove the exhaust shuttle.
6. Place the shuttle into the bore. Gently fold the seal into the bore while keeping pressure on the end of the shuttle. Refit the end bonnet. The refitting of the manifold is the reverse of removal.

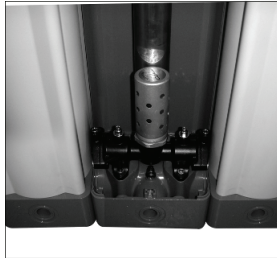

1

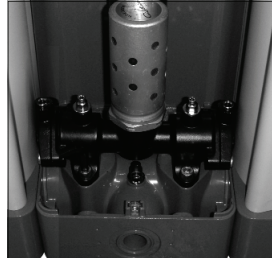

2

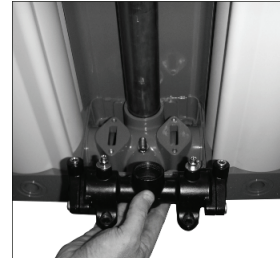

3



4



5



6

### 5.11 Resetting the controller

1. After following the start up procedure it is necessary to reset the controller. This is done by using the re-set disc (supplied with 12,000 hour service kit) then:
2. Hold the disc against the blue pad on the front display of the dryer panel for 5 seconds.
3. During the five second period the power indicator D will flash green. When the reset has been successful indicator B will flash red once to confirm that it has been completed successfully.



### 6.0 Dryer Troubleshooting

#### 6.2 Electrical troubleshooting (Reference display panel diagram)

Electrical Troubleshooting Guide				
Problem	Possible Cause	Display	Location	Action
No dryer function	No power supply	None		Check supply
Incorrect dryer operation	Left solenoid open or short circuit	Flashing red	X LED	Replace solenoid valve
	Right solenoid open or short circuit	Flashing red	Y LED	Replace solenoid valve
	Controller fault	Flashing red	Power LED	Replace controller
	Lower power fault	Continuous red	Power LED	Check supply
Drain not operating	Energy management active	None		Check installation
	Drain solenoid open or short circuit	Flashing red	Z LED	Replace solenoid valve
	Controller fault	Flashing red	Power LED	Replace controller



## 7.0 Replacement Parts

Any information, service or spare parts requests should include the machine serial number and be directed to:

**Patton's Medical**  
3201 South Boulevard  
Charlotte, NC 28209

Telephone: 1-866-960-0087

Fax: (704) 525-5148

[Medical.service@pattonsmmedical.com](mailto:Medical.service@pattonsmmedical.com)

[www.pattonsmmedical.com](http://www.pattonsmmedical.com)

### Replacement Parts

#### Dryer Kits

Dryer Model	Flow SCFM	12K Hour Kit A	24K Hour Kit B
64-02-004	4	40-09-016	40-09-024
64-02-006	6	40-09-000	40-09-025
64-02-008	8	40-09-001	40-09-026
64-02-010	10	40-09-002	40-09-027
64-02-015	15	40-09-003	40-09-028
64-02-025	25	40-09-004	40-09-029
64-02-035	35	40-09-005	40-09-030
64-02-045	45	40-09-005	40-09-030
64-02-055	55	40-09-006	40-09-031
64-02-065	65	40-09-007	40-09-032
64-02-085	85	40-09-008	40-09-033
64-02-105	105	40-09-009	40-09-034
64-02-135	135	40-09-010	40-09-035
64-02-175	175	40-09-011	40-09-036
64-02-215	215	40-09-012	40-09-037
64-02-275	275	40-09-013	40-09-038
64-02-365	365	40-09-014	40-09-039



**7.0 Replacement Parts (continued)**
**Dryer Kits (continued)**

Model	Flow SCFM	Valve Kit
64-02-004	4	40-09-054
64-02-006	6	40-09-054
64-02-008	8	40-09-054
64-02-010	10	40-09-054
64-02-015	15	40-09-054
64-02-025	25	40-09-054
64-02-035	35	40-09-054
64-02-045	45	40-09-055
64-02-055	55	40-09-055
64-02-065	65	40-09-055
64-02-085	85	40-09-055
64-02-105	105	40-09-055
64-02-135	135	40-09-055
64-02-175	175	40-09-055
64-02-215	215	40-09-063
64-02-275	275	40-09-063
64-02-365	365	40-09-063



**7.0 Replacement Parts (continued)**

**Dryer Kits (continued)**

Model	Flow SCFM	Pre-filter	Afterfilter
64-02-004	4	09-12-100	09-13-100
64-02-006	6	09-12-100	09-13-100
64-02-008	8	09-12-100	09-13-100
64-02-010	10	09-12-100	09-13-100
64-02-015	15	09-12-100	09-13-100
64-02-025	25	09-12-100	09-13-100
64-02-035	35	09-12-100	09-13-100
64-02-045	45	09-12-100	09-13-100
64-02-055	55	09-12-100	09-13-100
64-02-065	65	09-12-100	09-13-100
64-02-085	85	09-12-101	09-13-101
64-02-105	105	09-12-101	09-13-101
64-02-135	135	09-12-102	09-13-102
64-02-175	175	09-12-103	09-13-103
64-02-215	215	09-12-103	09-13-103
64-02-275	275	09-12-104	09-13-104
64-02-365	365	09-12-105	09-13-105

## 8.0 CO Monitor

### 8.1 Maintenance

#### 8.1.1 Calibration

Although the unit was calibrated at the factory, it may require re-calibration due to handling. The only way to assure a gas sensor is properly operating is to place gas on it.

To calibrate the unit with gas, shut off the air from the compressor supply line with the regulator and a low flow message will appear with the supply line shut off. Connect the tank of 20 ppm carbon monoxide test gas to the cal port connector on the instrument. Open the gas valve until the meter displays "CAL GAS" and a 60-second count down begins. Set the flow in the operating range of 0.5 to 0.9 CFH. If the compressor air supply line was not shut off, a message will appear SUPPLY OFF. If such a message occurs, shut off the supply air; and then reinitiate the cal process to activate the cal port switch.

After 60 seconds a gas reading will appear along with a COUNT NUMBER. With 20 PPM test gas applied the gas reading should be 20 and the count 70. At 70 counts with 20 PPM CO the unit will automatically set. The count number is used for trouble shooting (see trouble shooting section). After the unit auto-calibrates, a message will appear CO G SET indicating that the CO gain adjustment has been set for 20 PPM. Next an informational message on the automatic control pot value is displayed which also can be used for trouble shooting after the G (gain) SET message.

If an incorrect gas concentration is used or the sensor and instrument is not properly functioning, a message will appear CO G FAILED, PREV CAL, END CAL. This affords improper calibration protection and an effort should be made to understand why it did not calibrate (See trouble shooting section for assistance).

After proper calibration the next messages will be REMOVE CAL GAS, END CAL, SUPPLY ON. This prompts the calibrator to remove test gas and turn the supply on at the regulator.

In cases where zero gas calibration is needed, the unit can be automatically zeroed by inserting a small diameter wire in the zero cal opening near the cal port and pushing on a button switch. The hole is made inconveniently small so that an unbent paper clip may activate the switch but larger wire or devices will not. There are two conditions where pushing the zero button will activate zeroing:

## 8.0 CO Monitor

### 8.1 Maintenance (continued)

#### 8.1.1 Calibration (continued)

1. Holding the button for three seconds while air is coming from the supply line. In this case the zero button needs to be depressed until the zeroing message stops flashing and a solid zeroing message appears. The auto-zero process will begin without a countdown as it is assumed that air has been flowing from the supply line for more than a few minutes. If the supply line has more than one or two PPM of carbon monoxide, messages will appear BAD 0 AIR, PREV CAL, END CAL. The instrument is informing the user that it will not calibrate because of bad zero air; and it will use its previously zeroed cal setting. If the supply air is about 0 PPM concentration, the messages displayed will be CO 0 SET, END CAL that indicates that a new zero setting has been accepted and is now in use.

2. A second method for zeroing is to place zero test gas in the cal port similarly as described above with calibration gas, and the unit will initiate its calibration gas routine. However, the unit expects that 20 PPM CO or another cal gas concentration that was inserted in the setup mode is being applied in the cal port unless the zero button is pushed. Check to see that the message now says zero gas instead of cal gas as the 60- second countdown proceeds. Any time during the countdown the zero may be pushed to have the unit know that zero gas is being applied. If the button is not pushed, a bad air message will appear resulting in returning to the previous calibration. This is the error protection.

After the zero button is depressed, a ZEROING message appears and then RELEASE UNLESS ZERO INT message. Holding the zero button for 15 seconds will reinitialize a unit, which is used when replacing a sensor or as discussed in the trouble shooting section.

#### 8.1.2 Sensor Checkout and Changing

To check a sensor's response, test gas has to be placed on the sensor. When it fails to show a gas response during calibration, a new sensor is required. Most sensors will last from one and one-half years to two and one-half years.

To replace the sensor, disconnect the power to the unit and remove the four corner screws and the electronics front cover as described in the mounting section. Next remove the three screws that hold the sensor block and unplug the sensor from its socket. Replace with a new sensor after being sure that the shorting-wire is removed from the new sensor. Re-assemble the unit and reconnect to power. Let the new sensor settle in for an hour prior to calibrating. When calibrating with a new sensor, an initializing step is added to the calibration procedure that eliminates the error protection that is afforded after a sensor has once been calibrated. In effect this permits the sensor to be zeroed on any

## 8.0 CO Monitor

### 8.1 Maintenance (continued)

#### 8.1.2 Sensor Checkout and Changing (continued)

background air and caution needs to be taken that the air is free of carbon monoxide. If the supply line is not CO free, then obtain a tank of impurity free air test gas from Patton's Medical. To initialize the unit hold the zero button depressed for 15 seconds without the supply line air on or with impurity free air on the cal port. During the fifteen seconds the messages will read:

ZERO CAL, RELEASE UNLESS ZERO INT, INTIT-ING. Release the zero button when INIT-ING appears and the display will read: ZERO GAS REQUIRED. Flow zero gas from either the supply line or cal port and the unit will set its zero after 60 seconds. The instrument message will then read CAL GAS REQUIRED. When placing 20 PPM cal gas or another value selected in the set-up mode on the unit, it will calibrate after a minute and the next message will read END CAL, REMOVE GAS, SUPPLY ON. After turning the supply gas on, the unit will have the error protection and will be reading the carbon monoxide level of the compressor supply line.

## 8.0 CO Monitor

### 8.2 Troubleshooting

**WARNING:**

**Before removing the CO sensor, verify that line pressure has been valved off or reduced to atmospheric pressure.**

Before servicing the CO sensor, do the following:

1. Unplug sensor(s) or turn off monitor.
2. Depressurize the CO sensor.

**Note:** Remote alarms will be activated.

Problem	Possible Causes	Solution
CO Alarm - 10 ppm or above	Unit out of calibration	Calibrate unit
	Inlet air to the medical air system is contaminated	Move air inlet location or remove source of CO contamination
CO Alarm (Red light on monitor) but not on control panel	Communications equipment interference	Observe monitor alarm light. Monitor alarm light should go off after communications interference is removed.
Monitor will not calibrate	Sensor depleted	Replace sensor

### Count Numbers

Another set of numbers is displayed during calibration other than the gas concentration. These numbers are there to assist in trouble shooting in case zero or cal fails or other malfunctions occur. These other numbers are called counts.

The zero cal will not set if the counts are less than 46 or greater than 53 and when the unit sets at zero the number will read 50 ± 1 count. With 20 PPM cal gas the count number will be 70 ± 1 to set. If the computer cannot auto-adjust the readout to these values of 50 and 70, the zero or calibration will fail.

### Zero Fail During Calibration

If a failure occurs during zero cal, it means the counts are not between 46 and 53. If the counts are above 53, a BAD AIR message occurs and the zero air should be questioned for CO content. When the count level is below 46, it may

## 8.0 CO Monitor

### 8.2 Troubleshooting (continued)

be a malfunctioning unit or during initial zero calibration (without the error protection) it was zeroed with a concentration of gas on it.

Another initialization will remove the 46 to 53 count restraints, and with known zero air the unit may be re-zeroed. If

the counts never reach 50, the unit is malfunctioning, call the factory for further instructions.

#### **WARNING:**

**Before removing the CO sensor, verify that line pressure has been valved off or reduced to atmospheric pressure.**

### **Calibration Gas Fail During Calibration**

With 20 PPM gas on the unit the gas reading should reach 20 PPM and 70 counts. If the reading does not reach 70 counts, use the appropriate following procedure.

1. If the counts or gas reading do not show any increase when the gas is applied, probably the sensor is expired or the test gas is zero concentration. Check hose connections to assure gas is flowing into sensor chamber.
2. If the counts are close to 70, a zero reinitializing with known zero gas will probably correct the problem. If the unit was initialized with more than couple PPM of CO, the cal will fail when 20 PPM test gas is applied.

CAUTION: Be sure that the air is zero CO concentration when zero initializing.

## 9.0 Ceramic Dew Point Monitor (Standard)

### 9.1 Specifications

#### 9.1.1 Sensor

Sensor accuracy (repeatability, hysteresis, and linearity):  $\pm 2^{\circ}\text{C}$  ( $\pm 4^{\circ}\text{F}$ ) (For a 2-year period, with clean hydrocarbon free air supply. Patton's Medical recommends quarterly verification of air quality.)

Operating pressure range: 0 to 150 psig (0 to 1,034 kPa)

Air consumption: 0.2 - 0.5 LPM (0.42 - 1.0 SCFH) with 50 psi line pressure

### 9.2 Maintenance Schedule

Maintenance	Frequency	Action
Check flow through orifice	Every 6 months	Check for proper flow
Replace/Recalibrate Sensor	Every 24 months	Replace Sensor



## 10.0 Warranty

**Patton's Medical** warrants the total Medical Air system to be free of defects in material and workmanship under normal use for a period not to exceed twenty-four months from start-up, or thirty months from date of delivery. This warranty covers all necessary parts used in repair as well as all reasonable labor expense. Normal consumable parts required for routine scheduled maintenance (such as filters) are not covered under this warranty.

This warranty does not apply to products that are damaged by external causes, or are improperly warehoused, used, installed, serviced, or maintained by the customer. The sole liability for **Patton's Medical** under this warranty is limited to repairing, replacing, or crediting, at its election, any such products provided that:

- **Patton's Medical** is notified promptly within the warranty period above of any warranty claim.
- The examination of such items by an authorized representative of **Patton's Medical** will disclose to their reasonable satisfaction that claimed products defect has not been caused by misuse, neglect, improper handling, installation, repair, alteration, or accidents.

Product modification performed by the customer without prior written approval by **Patton's Medical** will invalidate the above warranty.

**This warranty is given in lieu of all other warranties, expressed or implied, including implied warranties of fitness for a particular purpose and merchantability. In no event shall Patton's Medical be liable for damages in excess of the value of the defective product or part, nor shall Patton's Medical be liable for any indirect, special or consequential damages, loss of profits of any kind, or for loss of use of the products.**

**Patton's Medical** shall not be liable to the customer for any claims, loss of damage of any kind whatsoever arising from the nonperformance of **Patton's Medical** of any part of this agreement occasioned by acts of God, fire, war, labor difficulties, governmental regulations, or action of government. **Patton's Medical** shall not be liable to the customer for any other cause, whether of a similar or dissimilar nature beyond its reasonable control.



**11.0 Maintenance Record**

**Model Number** \_\_\_\_\_

**Serial Number** \_\_\_\_\_

**Installation Date** \_\_\_\_\_

<b>Date of Service</b>					
<b>Hours</b>					
<b>Ambient Temp.</b>					
<b>Inlet Filter</b>					
<b>After Filter</b>					
<b>Misc.</b>					
<b>Serviced By:</b>					

**Notes:**



**11.0 Maintenance Record**

**Model Number** \_\_\_\_\_

**Serial Number** \_\_\_\_\_

**Installation Date** \_\_\_\_\_

<b>Date of Service</b>					
<b>Ambient Temp.</b>					
<b>Inlet Filter</b>					
<b>After Filter</b>					
<b>Misc.</b>					
<b>Serviced By:</b>					

**Notes:**



3201 South Boulevard  
Charlotte, NC 28209  
1-866-960-0087